



Power, Special Test Equipment (PSTE) Overview

AMETEK[®]
PROGRAMMABLE POWER

9250 Brown Deer Road
San Diego, CA 92121
USA

858 450-0085 Phone
858 458-0267 Fax
www.programmable.power.com

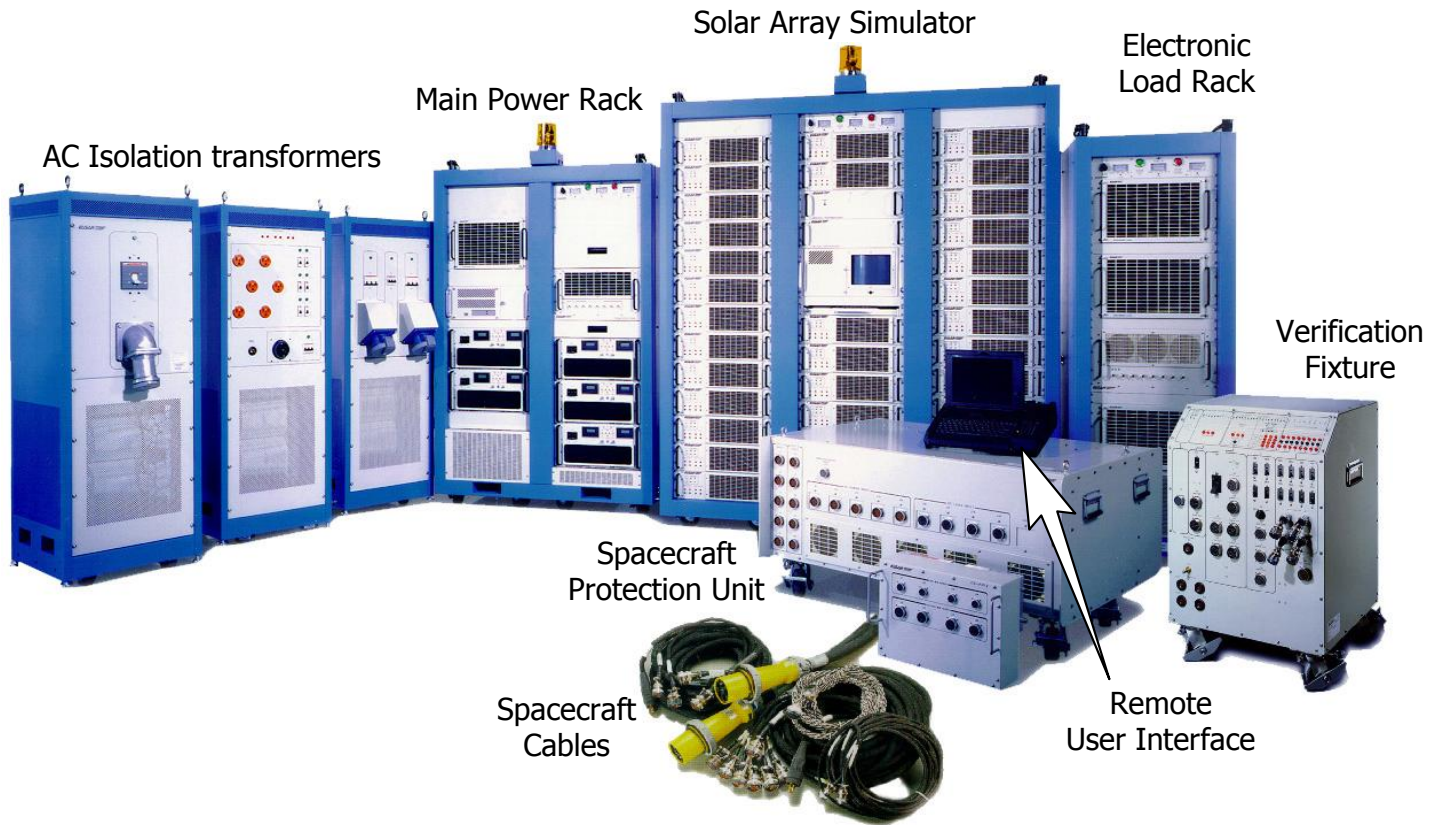



Company Overview

AMETEK Programmable Power, formerly Elgar Electronics Corporation and California Instruments, is comprised of the Elgar, California Instruments, Sorensen, AMREL and Power Ten brands and is located and headquartered in San Diego, California, with over 360 employees. Within three facilities totaling more than 115,000 square feet (13,000 square meters), all equipment produced by the Programmable Power Division are designed and most are manufactured in our San Diego facilities.

Elgar and California Instruments Brand AC Sources

Since their beginning in the mid-sixties, Elgar and California Instrument’s products have been used around the world in a variety of Test & Measurement applications. These programmable AC power sources are designed to meet a wide variety of commercial, industrial and military power requirements and have earned the company a reputation for quality and reliability in programmable power related products.

Sorensen and Power Ten Brand Hi Power DC Sources

Sorensen has been a leading manufacturer of high quality power supplies since 1946 and specializes in providing programmable DC power systems for a variety of OEM and test and measurement applications. Power Ten provides bulk power products into the Process Control and Test and Measurement markets.

Engineered Solutions Group

AMETEK Programmable Power’s Solutions Business provides product customization to meet specific customer requirements. The solutions range from OEM integration to turnkey integrated system solutions like solar array and battery simulators for ground-based satellite testing. In fact, the Solutions group has been selected to supply solar array simulators systems on more satellite programs than any other company worldwide. The Solutions group is especially skilled at providing custom solutions using existing technology and previously developed integration solutions. This approach provides maximum functionality, short lead times and maximum value.

When a catalog product cannot completely satisfy a requirement...

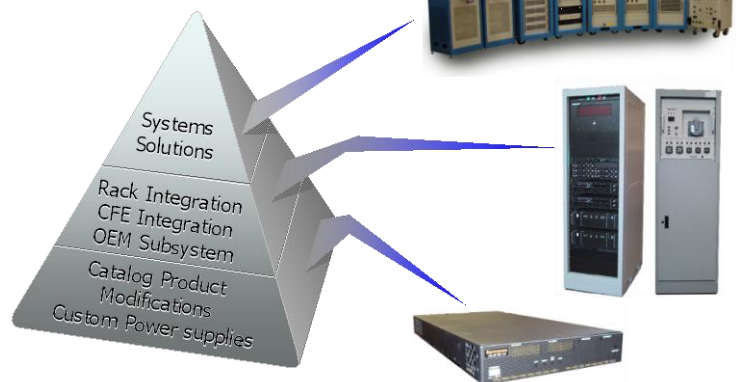



Management Team

AMETEK Programmable Power's management team is responsible for the company's operations and in certain areas has dedicated focus activities, such as the Solutions Group. The organization chart shown represents the Senior Management of the company.

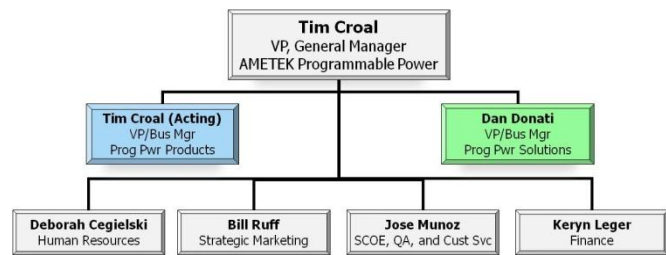

The nature of the Solutions business involves a high degree of project management involvement with dedicated program management support reporting to the VP/Business Manager of Programmable Power Solutions. With regard to this project, a Program Manager and Project Engineer are responsible for all technical and operational items from contract release to installation.

Design and Procurement

Solutions are predominantly a "standard" integration and therefore require little additional extraordinary design activities. Due to the fact that AMETEK uses common components and subassemblies throughout the Engineered Solutions operations, we have already established a qualified supplier base and constantly work with this select proven base to establish the best value to our customers.

Manufacturing, Assembly and Acceptance Test

AMETEK Programmable Power has invested in the expansion of our Engineered Solutions production facilities to handle the rapid growth of this segment of our business. The final integration and test area is 2080 ft (2207 m²) and can accommodate at least 5 to 10 systems a month depending on the size and type. Other workspace will be made available to facilitate the efficient execution of the contract. A specially trained team from production operations performs production assembly and test of all Engineered Solutions.

Each system will undergo an extensive acceptance test. This acceptance test procedure will be provided in advance of the test and the results provided upon shipment.



Documentation control and configuration management

Each solution is uniquely configured to meet the customer's application. The configuration has been established via technical interchange between the customer and AMETEK Programmable Power and is described in this quotation. Each system is identified with a top-level part number and will be under configuration control at AMETEK Programmable Power. Any subsequent change to the configuration of this system will require an Engineering Change. This protects the customer by assuring that any future systems are fabricated identically to the previous delivery.

Additionally, each system will ship with an operator's manual and a top level drawing package.

Quality System

The administrative infrastructure of AMETEK's Quality Assurance Program fully complies with the requirements of MIL-I-45208A that supports high end military, commercial/industrial and space systems requirements. The Quality Assurance Program also is in full compliance with the Code of Federal Regulations, Title 10, Part 50, Appendix B as applies to field service, spares, repair and technical support for ELGAR equipment which was qualified for Class 1E applications in Nuclear Steam Power Electric Generating Power Stations located domestically and abroad. These core administrative programs coupled with state-of-the-art design, manufacturing technology, such as Demand Flow Technology (DFT), workmanship standards, such as IPC 610, and process controls yield a highly efficient Program that is tailored to meet evolving requirements.

MIL-I-45208A had attained wide acceptance, for both military and commercial programs, over the course of several decades of use. While DoD restricts invoking such standards on new contracts, many military specifications and standards remain viable instruments for commercial use where they have been successfully in place and tailored to compliment more dynamically evolving engineering and manufacturing technologies.



NASA 2005 Quality Award

The Engineered Solutions Group was the proud recipient of a Quality and Service Award to NASA Jet Propulsion Lab in support of their quest to develop cutting edge technologies. We are deeply honored to have been recognized for our contributions.



National Aeronautics and Space Administration

--To understand and protect our home planet
--To explore the universe and search for life
--To inspire the next generation of explorers
...as only NASA can

As the nexus of NASA's major aeronautical and space programs, NASA Headquarters is the voice of the Agency. It integrates NASA as an aggregate sum of its many parts. By prioritizing budget directions and providing customer-driven aeronautics and space programs, internal NASA planning has helped thrust the U.S. aircraft and airline industries into positions of leadership in global aviation.

NASA is an organizationally complex Federal agency with a mission that spans a vast range of cutting edge technologies. To accomplish NASA's mission, NASA has established several geographically dispersed field centers and has assigned responsibility among them for broad program areas and projects, some of which Elgar Electronics Corp. has been a part of.



Two rovers, working on opposite sides of Mars, successfully completed their primary mission in April 2004. By that time, NASA's Opportunity rover had discovered evidence in rocks' composition and textures indicating that a body of salty water had once flowed gently across the area where it had landed. Spirit drove more than 3 kilometers (2 miles) to reach a range of low hills where it found exposed bedrock to examine. As of September 2004, both rovers are now in extended missions.

Supplier Outreach and Process Control
For more information on NASA projects, visit:
<http://www.nasa.gov/missions/highlights/index.html>

Process Control
Quality of Power



<http://marsrovers.jpl.nasa.gov>

Mars Exploration Rovers



The rover's Solar Panels provide power for recharging the batteries, driving the rover, operating the science instruments, and heating the Warm Electronics Box. At the beginning of the mission, the solar arrays will generate about 140 watts of power for up to 4 hours per day, but by the end of the mission, a combination of dust on the solar panels, weaker Martian sunlight, change in season, and degradation of the batteries will reduce that amount to about 50 watts, too little power to permit the rover to drive or keep warm at night. Surprisingly, the rovers have enough power even today to continue roaming the planet.

Elgar Electronics provided a Solar Array/Battery Source Simulator, which was used as a power subsystem for the rovers in the testing. It was also used to simulate different time and power ratings as well as different environments such as day and night. It also gave JPL the dynamic control over inputting minimum and maximum power into the system. Elgar's products served as a safety factor in the testing.



Elgar Electronics Corporation

A Major Contributor to NASA Programs

Elgar Electronics has been providing the market with power related products since 1965. The company supported several NASA programs including the MER, SIM, DAWN, LISA, DSN, and Prometheus. To learn more about these programs, please visit their website.

Prometheus
<http://prometheus.jpl.nasa.gov>



Elgar Electronics provided power supplies to JPL for use in ground testing of development hardware. Specifically, several of the power supplies that run the Prometheus NEXTIS ion thruster are from Elgar. JPL has more than a dozen of these supplies running thrusters. Prometheus will orbit Jupiter's icy moons to perform extensive investigations of their composition, history, and potential for sustaining life.

DAWN
<http://dawn.jpl.nasa.gov>



Dawn, the first spacecraft ever planned to orbit two different bodies after leaving Earth, will orbit Vesta and Ceres, two of the largest asteroids in the solar system. Elgar Electronics provided a solar array simulator for DAWN.

SIM PlanetQuest
<http://planetquest.jpl.nasa.gov>



SIM PlanetQuest, scheduled for launch in 2011, will determine the positions and distances of stars several hundred times more accurately than any previous program. Elgar Electronics provided their products to support this program.

LISA
<http://lisa.jpl.nasa.gov>



The Laser Interferometer Space Antenna will observe gravitational waves from binary stars both inside and beyond our galaxy. Elgar Electronics provided their products to support this program.

DSN
<http://deepspace.jpl.nasa.gov/dsn>



The Deep Space Network is an international network of antennas that supports interplanetary spacecraft missions and radio and radar astronomy observations for the exploration of the solar system and the universe. Elgar Electronics provided their products to support this program.



World-Wide Installed Base



Over 200 SAS and other systems are installed worldwide and are used on more production spacecraft than any other system available. It is the only system available from the original manufacturer as a complete, warranted system. A short list of our customers is provided below:

North America

Ball Aerospace
Boeing
Bristol Aerospace
Jet Propulsion Laboratory
Lockheed Martin
Orbital Sciences
NASA
Northrop Grumman
Space Systems Loral

Asia

KARI and KAI
NEC-Toshiba
Mitsubishi
Institutes 805, 501, 511

Europe and Middle East

Astrium - France
Astrium - Germany
Astrium - UK
Clemessy
European Space Agency - ESTEC
Israeli Aircraft Industries
Patria Space
SELEX - Galileo Avionica
Siemens AG Österreich
Surrey
Swedish Space Corporation
Terma Aerospace
Thales Alenia Space -ETCA
Thales Alenia Space - France
Thales Alenia Space - Italy



PSTE system Mission

The Elgar Power Special Test Equipment (PSTE) provides programmable DC power, and programmable loading, to the electrical systems of satellites for system functional testing.

There are several key benefits of the PSTE. First, it is a complete turnkey system that is capable of operating locally through a simple GUI interface or remotely via a host computer as a single Ethernet address. The spacecraft engineer who defines the spacecraft power bus limits, cabling scheme, mode simultaneity matrix, and system behavior based upon limit conditions implements the real intelligence of the system. From this definition, operating procedures can be generated to allow spacecraft technicians to operate the system, system protections are implemented that perform cable detection and mode verification, automated spacecraft fixture identification and related mode capability, and more.

Second, the PSTE is intended to negate the need for purchasing new power test equipment with each new spacecraft. With a review of current and future needs and industry trends, power resources can be sized to provide the optimal blend of flexibility and price.

The system also monitors and provides protection for the satellite electrical power systems against any damage by programming error or by system failure.

The following resources are available in the system pictured on the cover. In most cases, the hardware resources can be scaled to meet the customer's individual requirements.

AC Isolation transformers

- 75KVA power rating; Transform 480VAC 3phase Delta to 208VAC 3 phase Wye

Main Power Rack

- Five 10KW power channels; 150VDC at 67A each
- One 5KW load channel; 3-450V, 0-150A constant current
- Eight programmable strip chart recorder outputs

Solar Array Simulator

- 64 Channels with 110V Voc and 450W each

Electronic Load Rack

- Three 5KW load channel; 3-450V, 0-150A constant current

Remote User Interface

- Ruggedized Portable PC with operator interface software

System Verification test Fixture

- Customized for individual spacecraft I/O to allow convenient, manual verification of power setup.



Hardware Overview

In this section, the overall system is first represented by a simplified block diagram along with a general discussion of the function of each equipment rack. After which, each rack of equipment is represented by its own block diagram. Each rack block diagram is supported by a discussion of the equipment in the rack.

System Block Diagram

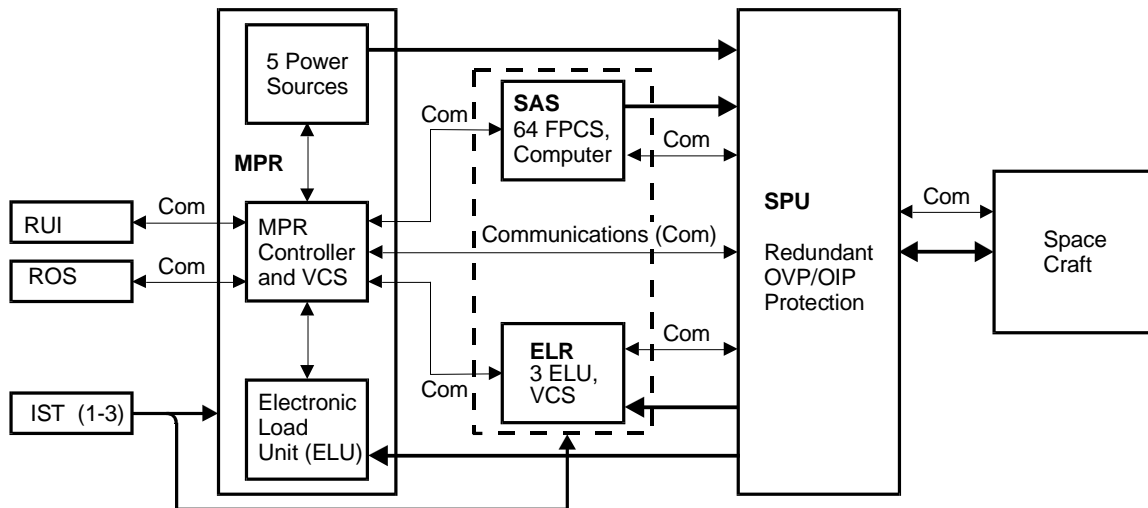

Figure 1: Simplified PSTE Block Diagram

Either the Remote User Interface (RUI) or the Remote Operating System (ROS) is the source of control, or Computer in Charge (CIC), at any given time, at the operator's discretion. The ROS is supplied by the user. The CIC communicates directly with the system controller in the MPR (MPR controller), and the entire system is controlled via the MPR Controller.

Diagnostics and Troubleshooting can be accomplished directly from the MPR controller. The Main Power Rack (MPR) provides main bus power for tests from up to five internal power sources. The Solar Array Simulator (SAS) provides solar panel simulation power. The Spacecraft Protection Unit (SPU) further protects the spacecraft from damage in case of failure of the built-in OVP/OIP protection of the rest of the PSTE system. For electrical system loading tests, the Electronic Load Rack (ELR) provides three programmable Electronic Load Units (ELU). The MPR contains an ELU that can be used when only one ELU is required.



The following are the block diagrams for each of the main racks (subsystems) of the PSTE system.

MPR Block Diagram Descriptions

The MPR Contains three major subsystems: the test power sources, the ELU and the MPR Controller. The MPR Controller is the central control point for the rack and for the entire PSTE system.

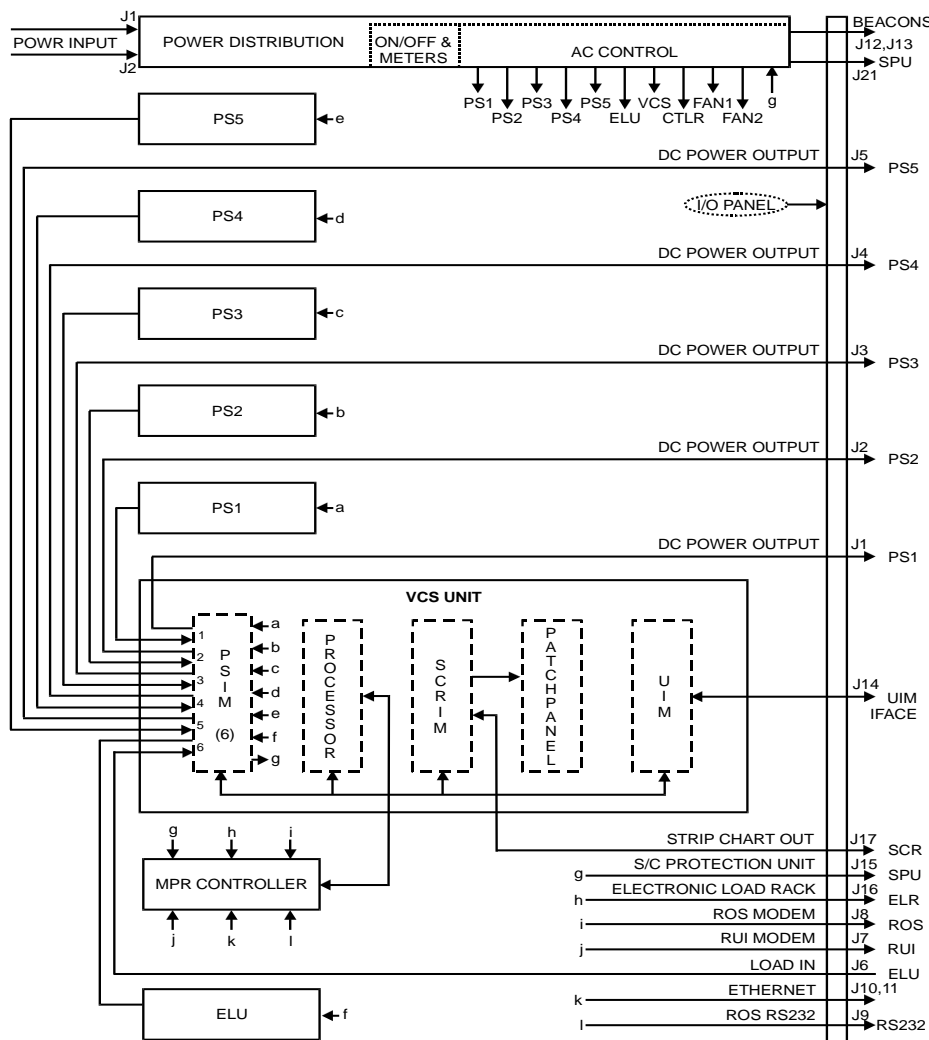

Figure 2: MPR Block Diagram



Power Distribution

Power Distribution provides AC operating power to all units in the rack. It consists of the AC Control unit and the ON/OFF & Meter panel. When the system is operated with the SPU, it also provides the 24 V dc required by the SPU.

The 208 VAC, 80 A, 3-phase (Wye) operating power enters the AC Control unit through its AC Control panel, which is accessible from the rear of the rack. Power must be applied to both inputs, J1 and J2, or the rack will not power up.

The ON/OFF & Meters panel, accessible from the front of the rack, is the master manual switching panel for powering the rack. It provides ON/OFF and Standby pushbutton switches for the input power. Power comes on only if AC Control panel J1 and J2 inputs are both within the voltage specification for the rack. In Standby, power to four of the DC test power sources (PS1, 3, 4 and 5) and to the cooling fans is removed. The ON/OFF & Meters panel also provides analog readouts of the line-to-neutral voltage of each of the three phases.

The signals controlling application of power to the DC power supplies come from five of the six Power Source Interface Modules (PSIM) in the Voltage and Current Sense (VCS) unit. The signal that controls the beacon comes from the MPR Computer.

DC Power Source

The DC Power Source is made up of five 150 V, 66 A, 10 k W, DC Power Supplies. The specific type and power can be substituted and configured to meet customer's requirements. The Power Supplies are operated exclusively in voltage mode.

Each of the power supplies is controlled by a Power Supply Interface Module (PSIM) in the MPR Controller unit. PSIM controls include all supervisory functions such as overvoltage response, overcurrent response, and open sense response.

Power Source Interface Modules (PSIM)

The VCS unit houses the six PSIM modules. Five of the PSIM control and monitor the five DC Power Supplies (PS1-5). One PSIM controls and monitors the single ELU that resides in the MPR.

The PSIM are VME based, and each contains a digital signal processor (DSP). The DSP communicate with the VCS Processor module through dual port memory via the VME bus. The system accesses the PSIM via the Elgar VCS.exe software module, executing on the MPR Computer.

All current flowing from a PS or flowing into the ELU passes through the PSIM for that unit. (These are PSIM lines 1-6 in the block diagram) The PSIM measures current and voltage,



and provides supervisory protection for high side and low side current limit, local and remote overvoltage, ground overvoltage, open sense, and for the ELU: thermal shutdown. (These are PSIM lines a-f in the block diagram.)

A digital output signal (PSIM line m in the block diagram) controls the AC input contactor for that supply in the AC Control unit.

VCS Processor Module

The VCS Processor module functions as the VCS VME Bus Controller. It is the interface between the MPR Controller and the other VCS modules. It communicates with the MPR controller via two RS232 ports. The system accesses the PSIM via the Elgar VCS.exe software module, running on the MPR Controller.

Strip Chart Recorder Interface Module (SCRIM)

The SCRIM, in the VCS unit, provides eight independent channels of scaled output. These go to both the VCS patch panel and the Strip Chart Recorder output connector.

The SCRIM consists of eight 14-bit digital to analog (D/A) converters, which are memory mapped into the VCS Processor memory. The SCRIM D/A converters read status data, which has been digitized by the VCS, from the VCS Processor memory. There are many channels of status data stored in the Processor memory, and the user must select the channels read by the SCRIM. This can be done from the MPR Controller or from the RUI. The D/A converters then output analog representations of the selected data.

Umbilical Interface Module (UIM)

The UIM is a 16-bit analog to digital (A/D) converter with an 8-channel input multiplexer. The S/D converter is memory mapped into the VCS Processor memory. The UIM writes digitized data into memory, which in turn is read and acted upon by the Processor module.

The UIM output includes:

- Two channels of 100 V BPDU measurement
- Two channels of 30 V BPDU measurement
- Battery Disconnect Command (BDC) Output
- Four channels of Battery Temperature Measurement
- Cable detect input.

MPR Controller

The MPR Controller is the main intelligence for the entire PSTE system. It provides all of the interaction with both the Remote User Interface (RUI) and the customer supplied Remote Operating System (ROS), and it runs all of the system software applications modules for the MPR, ELR, SPU and SAS.



The MPR Controller is an Intel Pentium-based industrial computer. It currently uses the Windows NT operating system.

No monitor or keyboard is required for normal operation. However, maintenance screens for each service application can be accessed by using a keyboard, monitor and mouse, through auxiliary front panel ports on the controller or by configuring the system with these assets.

Electronic load Unit (ELU)

The ELU is a high performance, 5kW, 100A, electronic DC load capable of operating in both static and dynamic modes. It is controlled and monitored by a PSIM module in the VCS unit, which provides all protective functions for the ELU. The ELU contains none of its own supervisory protection.

ELR Block Diagram Description

The ELR Contains two major subsystems: the ELU and the VCS unit. The VCS unit is the central control point for the rack. Figure 3 is the ELR Block Diagram.

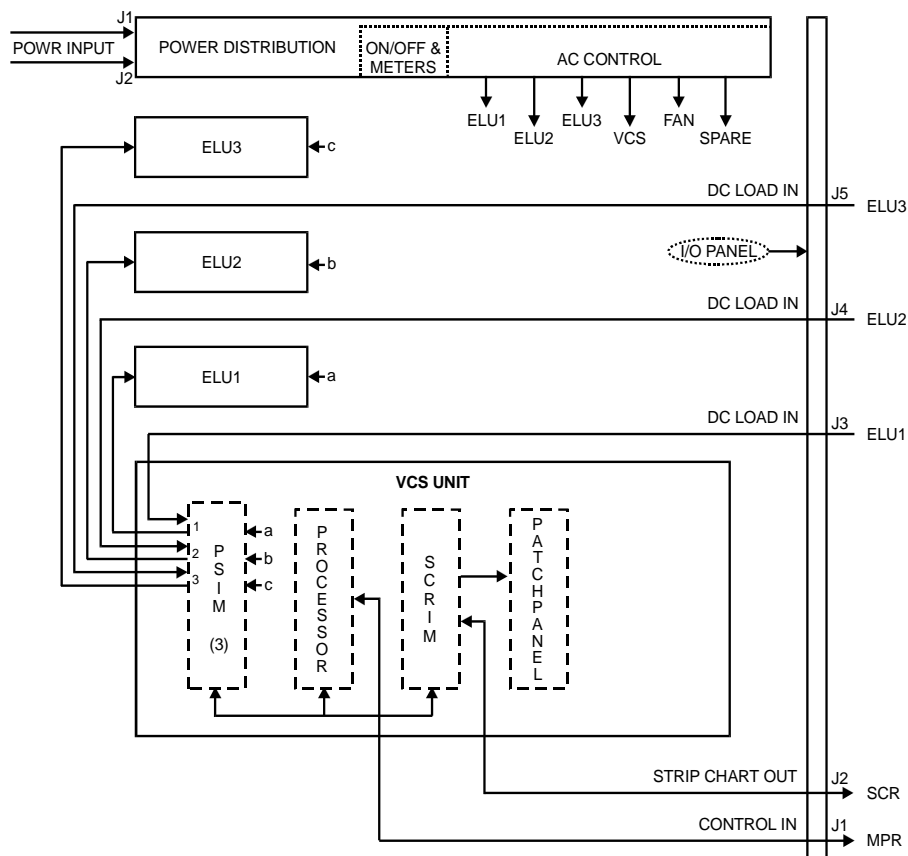

Figure 3: ELR Block Diagram



Power Distribution

Power Distribution provides AC operating power to all units in the rack. It consists of the AC Control unit and the ON/OFF & Meter panel. The 208 VAC, 30 A, 3-phase (Wye) operating power enters the AC Control unit through its AC Control panel, which is accessible from the rear of the rack.

The ON/OFF & Meters panel, accessible from the front of the rack, is the master manual switching panel for powering the rack. It provides ON/OFF and Standby pushbutton switches for the input power. Power comes on only if the input to the AC Control panel is within the voltage specification for the rack. In Standby, power to the Electronic Load Units (ELU) and the cooling fans is removed. The ON/OFF & Meters panel also provides analog readouts of the line-to-neutral voltage of each of the three phases.

Electronic Load Units

There are three ELUs in the ELR. Each is a 5kW, 100A, electronic DC load, which is capable of operating in both static and dynamic modes. Each ELU is controlled and monitored by its own PSIM module in the ELR VCS unit. (See *Power Source Interface Module* below.) The three ELU can be operated separately or paralleled to handle higher power when required.

Power Source Interface Modules

The system accesses the PSIM via the Elgar VCS.exe software module, executing on the MPR Computer. The three PSIM reside in the ELR VCS unit. Each PSIM provides voltage control, current programming, and supervisory protection to one ELU. The PSIM are VME based, and each contains a digital signal processor (DSP). The DSP communicate with the VCS Processor module through dual port memory via the VME bus.

All current drawn by an ELU passes through its PSIM module. Supervisory protection is provided for current limit, local and remote overvoltage, open sense, and thermal shutdown. Digital inputs provide cable connect detection from the ELR Connector panels, and also monitor the Thermal Shutdown output of the ELU.

VCS Processor Module

The VCS Processor module functions as the VCS VME Bus Controller. It is the interface between the MPR Controller and the other VCS modules. It communicates with the MPR controller via two RS232 ports. The system accesses the PSIM via the Elgar VCS.exe software module, running on the MPR Controller.



Strip Chart Recorder Interface Module (SCRIM)

The SCRIM, in the VCS unit, provides eight independent channels of scaled output. These go to both the VCS patch panel and the Strip Chart Recorder output connector.

The SCRIM consists of eight 14-bit digital to analog (D/A) converters, which are memory mapped into the VCS Processor memory. The SCRIM D/A converters read status data, which has been digitized by the VCS, from the VCS Processor memory. There are many channels of status data stored in the Processor memory, and the user must select the channels read by the SCRIM. This can be done from the MPR Controller or from the RUI. The D/A converters then output analog representations of the selected data.

SAS Block Diagram Description

The SAS is made up of four basic building blocks: The Fast Profiling Current Sources (FPCS), the SAS Computer and communications, the AC Control chassis, and the Shutdown Board. Figure 4 is the SAS Block Diagram.

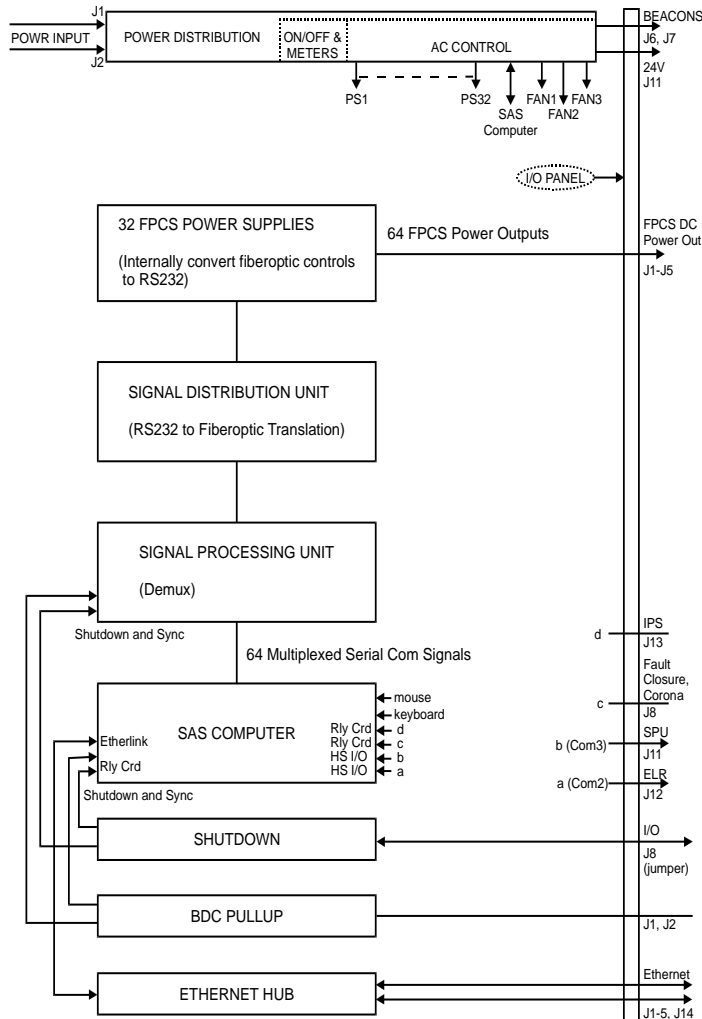

Figure 4: SAS Block Diagram



Power Distribution

Power Distribution system provides power to all units in the rack. It consists of the AC Control Unit and the ON/OFF and Meter panel. The 208 VAC, 80 A, 3-phase (Wye) operating power enters the AC Control unit through its AC Control panel, which is accessible from the rear of the rack. Power must be applied to both J1 and J2.

The power relays can be controlled manually from the System On/Off panel on the front of the cabinet. The power for the relay coils comes from a 24 V power supply in the AC Control chassis. When the green SYSTEM POWER ON button is pressed, the power relays are energized and power is distributed throughout the system.

The three phases and neutral are filtered on selected units. The three phases are protected by a three-pole circuit breaker. Each input is monitored for undervoltage and phase rotation. If a phase goes low or drops out, or if the phase rotation for any input is incorrect, the system will shut off. From the circuit breaker, each phase is wired to its own power relay. NOTE: the Control Computer is powered up whenever the circuit breakers are on.

Fast Profiling Current Source (FPCS)

The FPCS units are the main component of the system. There are three major sections of an FPCS: a Bulk Power Supply, a Housekeeping Power Supply, and two Power Modules (one for each channel). These special purpose power supplies emulate the output power characteristics of a solar array in that the I-V curve output is fully programmable. Aside from the static power simulation of the solar array, the system is capable of dynamically simulating Eclipse and rotation events on orbit. For more information on Solar Array Simulators please refer to the SAS overview document.

SAS Computer

In PSTE systems, the user programs the FPCS units remotely via the MPR processor or RUI. The MPR Communicates with the SAS Computer via the Ethernet link, and the SAS Computer communicates to the FPCS chassis via the RS-232 link. Inside the Control Computer, a 64-Port Digiboard emulates 64 serial ports—one for each FPCS channel.

Signal Processing Unit

The 64 serial ports are multiplexed and sent to the Signal Processing unit, which contains four 16-port modules connected in series. Each of the four modules de-multiplexes 16 serial ports (channels) for a total of 64 ports.



Signal Distribution Unit

The Signal Processing chassis ports are connected to the Signal Distribution unit. In the Signal Distribution unit, two Signal Translator cards can each handle serial communications for 32 channels. The serial communications are transferred to a maximum of eight Fiber Optic Translator cards. The Fiber Optic Translator card converts the RS-232 to fiber optic data. Each Fiber Optic Translator card has four pairs of transmitter/receivers. Each pair is connected to a single FPCS channel. The FPCS units then convert the fiber optic data back to RS-232. Fiber optics are used to keep the FPCS isolated from chassis ground.

Shutdown Interface

The shutdown board gets its power from the +24V power supply in the AC control chassis. The 24 volts is applied to a 5-volt regulator that produces the +5V signal to keep the FPCS from shutting down. The +24V is also applied, through a dropping resistor, to the shutdown pins on the I/O panel J8, and must be returned to that connector to keep the FPCS units operating.

When the circuit between the external shutdown pins is broken, the +5 V return path is removed, and the FPCS units shut down by opening their electronic circuit breaker within 5 μ sec. When the external shutdown connection is opened, a timer is also triggered which sends a signal to the SAS Computer, and from there to the PSTE CIC, telling it that an external shutdown was detected.

BDC Pull-up Resistor Module

The pull-up resistor module simply provides bias voltage to various gates within the rack equipment for their proper operation.



SPU Block Diagram Description

The SPU circuitry has three major parts: the five Power Supply OVP/OIP modules, The four Electronic Load OVP/OIP modules, and the Microprocessor. Figure 5 is a block diagram of the SPU.

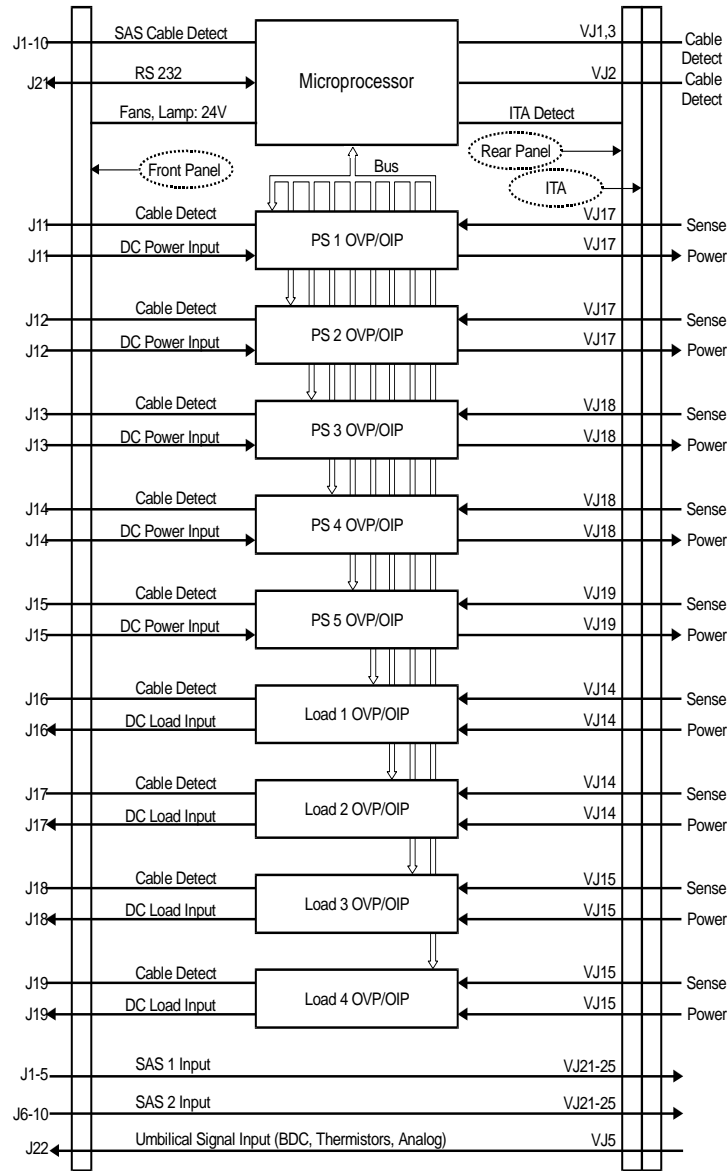

Figure 5: SPU Block Diagram



Power Supply OVP/OIP Modules

DC Power from the MPR connects to the S/C through the SPU PS OVP/OIP Modules. The power enters via the DC Power Input connectors on the front panel of the SPU and exits through the ITA panel on the rear of the SPU. Remote voltage and sense lines from the S/C connection points are returned.

Cable detect signals for the cables enter the OVP/OIP modules and are reported to the Microprocessor module through the bus.

If an overvoltage or overcurrent is not reported to the module via the sense lines, the power continues on to the S/C. If overvoltage or overcurrent is sensed, the module opens the power circuit to prevent power from reaching the S/C. The module reports this trip/no-trip status to the Microprocessor module through the bus.

Electronic Load OVP/OIP Modules

DC Power from the S/C connects to the Electronic Load through the SPU Load OVP/OIP Modules. The power enters via the ITA on the rear on the SPU, and flows out into the loads through the DC Load Input connectors on the front panel of the SPU. Remote voltage and sense lines from the S/C connection points are returned.

Cable detect signals for those same cables enter the OVP/OIP modules and are reported to the Microprocessor module through the bus.

If an overvoltage or overcurrent is not reported to the module via the sense lines, the power continues on to the S/C. If overvoltage or overcurrent is sensed, the module opens the circuit to stop drawing power from the S/C. The module reports this trip/no-trip status to the Microprocessor module through the bus.

Microprocessor Module

The Microprocessor continuously polls the OVP/OIP modules for Cable Detect and trip/no-trip status. It reports the status to the MPR Controller for action via RS232 through front panel connector, J21, and it keeps a status log.

The Microprocessor directly monitors the cable detect lines from the SAS, and reports this to the MPR Controller. It also manages the 24 V power to the cabinet, including the cooling fans, and detects the presence or absence of an ITA in the ITA receiver on the rear panel.

SAS Power and Umbilical Signal Lines

The SPU exerts no control over these lines, except to route them through the ITA receiver. These lines pass through only those ITA that need to access them.



Verification Fixture Block Diagram Description

The Verification Fixture Block Diagram, Figure 6, is divided into two parts: the Power Test channels and the Wire Test channels.

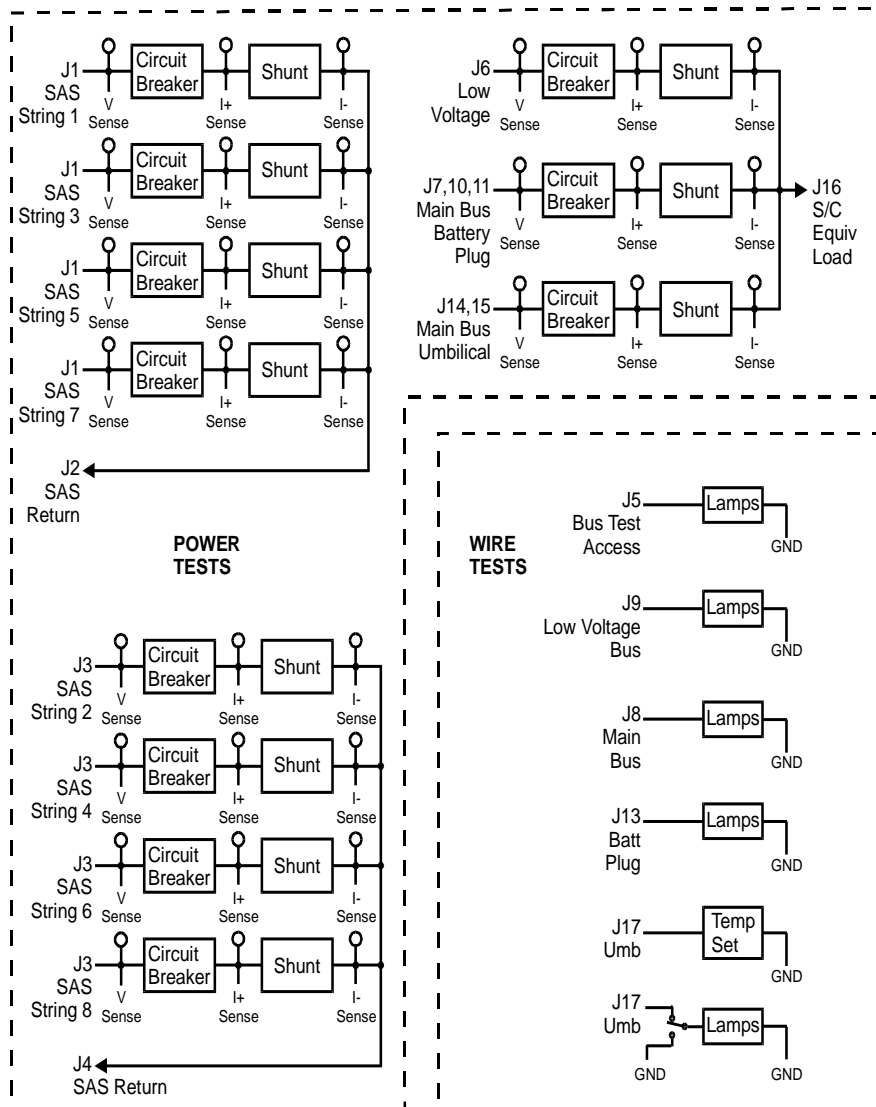

Figure 6: Verification Fixture Block Diagram



Wire Tests Block Diagram

Wire Test Connectors on the Verification Fixture are provided for the Bus Test Access, Low Voltage Bus, Main Bus, Battery Plug, and Umbilical cables. For the SAS cables, Wire Tests are performed simultaneously with the Power Tests.

The “Lamps” boxes represent a LED, diode and resistor in series for each conductor (or bundle of conductors—depending on the connector). The diode blocks current of the wrong polarity, and the resistor provides an appropriate load to ground. The LED light for a given conductor will not light if the cable is not powered, if polarity is reversed, if there is no continuity, or if there is extremely high resistance in the conductor.

Power Tests Block Diagram

J1 and J2 test the cables from SAS strings 1, 3, 5 and 7. J3 and J4 test the cables for SAS strings 2, 4, 6 and 8. J2 and J4 are the return paths.

For Low Voltage and Main Bus power tests, and for Battery Plug and Umbilical power tests, J16 connects to an external load that is designed to simulate the load presented by a S/C. The ELU supplied with the MPR and/or ELR can be used.

In each power test circuit, the Circuit Breaker protects the circuitry (in particular, the Shunt). The Shunt provides an extremely heavy load, with just enough resistance to provide a current reading from the voltage dropped across it.

IST Information

The IST is more than a Transformer. It also supplies spike and surge suppression. It is housed in a convection-cooled cabinet, with input and output connectors, circuit breakers, and pilot lights.



System Control Software Overview

All software is installed at the factory as an integral part of the PSTE system. This brief overview is presented for a basic understanding as an aid to troubleshooting.

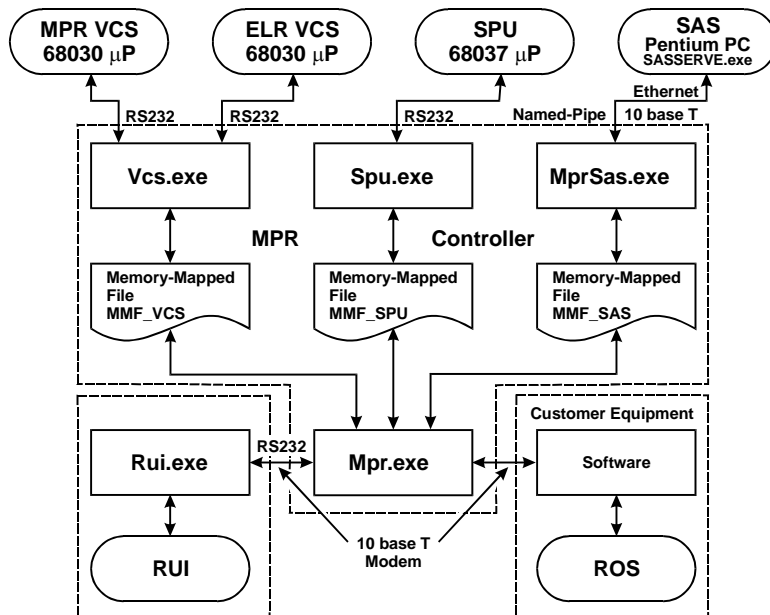

FIGURE 1: MPR SOFTWARE ARCHITECTURE

Figure 1 is a block diagram of the ELGAR PSTE software, which consists of the following six main modules:

- the RUI executable (Rui.exe)
- the MPR executable (Mpr.exe)
- the VCS executable (Vcs.exe)
- the SPU executable (Spu.exe)
- the SAS-MPR executable (MprSas.exe)
- the SAS-resident executable (SASSERVE.exe).

Commands to the system from the CIC are accepted and

processed by the Mpr.exe file. In turn Mpr.exe writes instructions to the VCS, SPU, and SAS through the three memory-mapped files: MMF_VCS, MMF_SPU, and MMF_SAS. When necessary Mpr.exe responds to the RUI and ROS.

Vcs.exe, Spu.exe, and MprSas.exe read the MPR instructions from their respective MMFs. They also write status data to their respective MMFs, which the Mpr.exe can then read, process, respond to if necessary, and relay to the RUI and ROS. Most of the status data are readable in decimal form from the troubleshooting screens, and the messages conveying them are also displayed there in hexadecimal form.



Example User Interface Screens

Solar Panel EX

SPS CONTROL

Voltage 50.000 V Current 60.000 A Ramp Up Step Size 10.000

QVP 63.500 V DIP 66.000 A Ramp Down Relay Disable RESET

CONTROLLING: ICD
Channels 1-28, 33-60

Voltage control setpoint reached.
Voltage control setpoint reached.
Circuit breaker trip ON.

	V Status	V Set	I Status	I Set	Relay Status
ICD	49.125	50.000	0.324	60.000	Relay Closed
North Wing	50.021	50.000	0.203	30.000	Relay Closed
String S/1	50.038	50.000	0.024	4.285	Relay Closed
String S/2	50.020	50.000	0.023	4.285	Relay Closed
String S/3	50.017	50.000	0.032	4.285	Relay Closed
String S/4	50.010	50.000	0.021	4.285	Relay Closed
String S/5	50.024	50.000	0.037	4.285	Relay Closed
String S/6	50.018	50.000	0.029	4.285	Relay Closed
String S/7	50.021	50.000	0.039	4.285	Relay Closed
South Wing	49.330	50.000	0.121	30.000	Relay Closed
String S/1	50.013	50.000	0.029	4.285	Relay Closed
String S/2	50.022	50.000	0.012	4.285	Relay Closed
String S/3	50.019	50.000	0.017	4.285	Relay Closed
String S/4	50.007	50.000	0.030	4.285	Relay Closed
String S/5	50.018	50.000	0.013	4.285	Relay Closed
String S/6	50.017	50.000	0.017	4.285	Relay Closed
String S/7	50.014	50.000	0.025	4.285	Relay Closed

Messages

IPS ALARM INPUT
Disabled

SPS Emergency Shutdown

Help

Umbilical Battery Charge

UMBILICAL BATTERY CHARGE CONTROL (EACH UMB)

Voltage 0.000 V Current 1.000 A

QVP 58.000 V Timed DIP 3.000 A

Remote Sense

Step Size 2.000 /ramp

Ramp Up Ramp Down

Battery Temp Limit 28.000 °C

UMBILICAL BATTERY CHARGE STATUS

Remote Voltage 1 0.234 V Total Current 1 0.000 A

Remote Voltage 2 0.234 V Current 2 0.000 A

Umb. Battery Charge Emergency Shutdown

Messages

Batt. Temp (°C)

	Present	Low
1	2.1	-26.7
2	22.3	-26.7
3	23.1	-26.8
4	12.5	-26.8

Help

Battery Charge Simulation

BATTERY CHARGE CONTROL

Current 0.000 A Step Size 2.000 /Step

QVP 35.000 A

Ramp Up Ramp Down

BATTERY CHARGE STATUS

Remote Voltage -0.009 V Total Current -0.045 A

Battery Charge Emergency Shutdown

Messages

Output path is open.

MODE SELECT

Static Standby

Help

Main Bus Power

MAIN BUS POWER CONTROL

Voltage 100.000 V Current 50.000 A Step Size 10.000 /ramp

QVP 105.000 V Timed DIP 55.000 A

Remote Sense

Ramp Up Ramp Down

MAIN BUS POWER STATUS

Remote Voltage 100.000 V Total Current 9.409 A

Main Bus Power Emergency Shutdown

Messages

Voltage control setpoint reached.
Current control setpoint reached.
Current control setpoint reached.

Help

Umbilical Main Bus

UMBILICAL MAIN BUS CONTROL (EACH UMB)

Voltage 0.000 V Current 2.500 A Step Size 2.000 /ramp

QVP 58.000 V Timed DIP 2.750 A

Remote Sense

Ramp Up Ramp Down

UMBILICAL MAIN BUS STATUS

Remote Voltage 1 -1.074 V Total Current 1 0.000 A

Remote Voltage 2 -1.074 V Current 2 0.000 A

Umb. Main Bus Emergency Shutdown

Messages

Regulation

Remote Toggle

Help

Battery Simulation

BATTERY SIMULATION CONTROL

Voltage 0.000 V Current 0.000 A Step Size 2.000 /ramp

QVP 55.000 V Timed DIP 1.000 A

Remote Sense

Ramp Up Ramp Down

BATTERY SIMULATION STATUS

Remote Voltage -0.026 V Total Current -0.045 A

Battery Sim. Emergency Shutdown

Messages

Help



Hardware/Software Interface

VCS-MPR-CIC Interface

This topic relates equally to the MPR VCS and ELR VCS, except where the ELR VCS does not include the component described.

The RUI converts operator input into commands, which are in turn issued to the MPR Processor, via TCP/IP (Ethernet), RS232, or modem. In the MPR Processor, the Mpr.exe software, converts the commands it receives into data, which are stored in shared memory structures (Windows NT memory mapped files). Data exchanges with the VCS unit are stored in the MMF_VCS file.

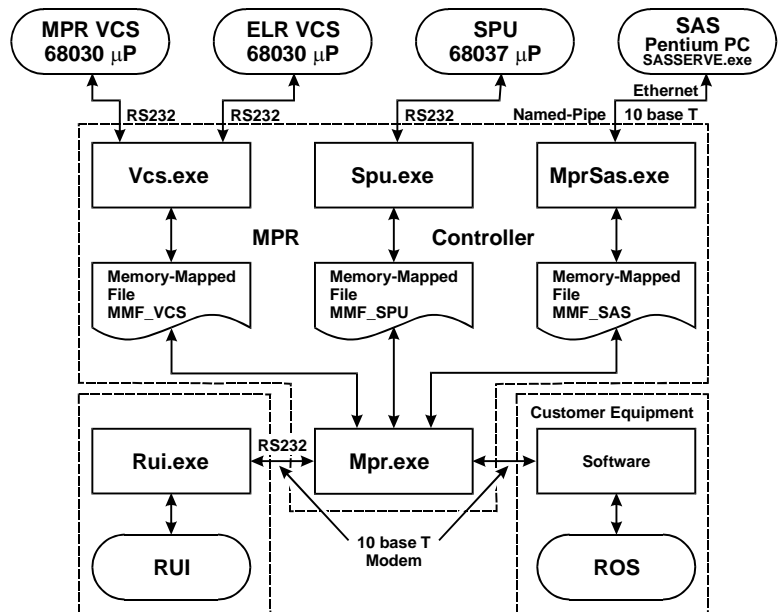

VCS.exe, detects changes to the VCS_MMF files and converts the new data into commands, which are sent via RS232 ports to the MPR VCS and/or ELR VCS firmware.

Commands received by the VCS firmware are stored as data in the dual port RAM and acted upon by DSP firmware running in the 68030 microprocessor. This DSP firmware in turn stores system information in the dual port RAM, and the VCS firmware sends these as messages via RS232 ports to the MPR where VCS.exe stores them as data in the appropriate VCS_MMF.

VCS.exe then converts the VCS_MMF data from the VCS firmware into TCP/IP (Ethernet), RS232, or modem messages, sent to the RUI and Received by RUI.exe. At the RUI, RUI.exe displays the information graphically on the screen.

SPU-MPR-CIC Interface

In the MPR Controller, data exchanges between the MPR and SPU are stored in the SPU_MMF file. SPU.exe, detects changes to the SPU_MMF files and converts the new data into commands, which are sent via RS232 ports to the SPU firmware.

It may be helpful at this time to compare this block with the SPU hardware block diagram before proceeding.

The SPU firmware, running on the 68307 processor, acts on the commands received to control the SPU responses. It converts the SPU system data to messages and sends them



via RS232 to the SPU_MMF. Refer to the MPR Computer block, inside the MPR Rack block, in Figure 2.

SPU.exe picks up the new SPU messages from the SPU_MMF, converts them to data, and stores them back in the SPU_MMF. Mpr.exe then reads the new data in SPU_MMF, converts them to TCP/IP (Ethernet) or serial (RS232 or modem) format, and sends them on to the RUI. At the RUI, Rui.exe displays the information graphically on the screen.

SAS-MPR-CIC Interface

Refer to the MPR Computer block, inside the MPR Rack block, in Figure 2.

In the MPR Controller, data exchanges between the MPR and SAS are stored in the SAS_MMF file. SPU.exe, detects changes to the SPU_MMF files and converts the new data into WinNT "Named Pipe" commands, which are sent via TCP/IP, on Ethernet, to the SPU firmware in accordance with the FPCS internal protocol, which is not published.

Refer to the SAS Computer block, inside the SAS Rack block, in Figure 4.

The internal SASSERV.exe sends the commands through signal processing to the control inputs of the FPCS units. The FPCS firmware converts SAS information into messages to SASSERV.exe. SASSERV.exe again converts the messages to Named Pipe, TCP/IP, and Ethernet format for MprSas.exe.

Refer to the MPR Computer block, inside the MPR Rack block, in Figure 2.

Messages received by MprSas.exe are converted into data stored in the SAS_MMF. MPR.exe gathers the new SAS data and converts them to TCP/IP (Ethernet) or serial (RS232 or modem) messages for the RUI. In the RUI, RUI.exe displays the data graphically on the RUI screen.