

INSTALLATION

Lars Laj products can be delivered worldwide with or without installation assistance. Deliveries for distant areas can be installed by the client themselves or with help of local installers. Each playground, as well as each particular unit, has its own detailed installation manual, ensuring that important safety aspects will be observed during installation.

LS90 + B90 - set for platform height 90cm - Installation manual



CONSULTATION

We offer plans and drawings for playground propositions free of charge, with no obligation to the customer. During the design process, the Lars Laj team always uses their knowledge and experience to help our clients make the right decision. Our consultants are there to listen and come up with a solution just right for you whether you need an entirely new playground, or would like to update, renew and upgrade an existing project.



"WOOD2WOOD" FOUNDATION SYSTEM



Our original "Wood2Wood" foundation system ensures durability and long life - without compromising on the environment

Advantages:

- Increased durability - only the oak base support is in contact with the ground
- Water resistant
- No soil corrosion problems normally associated with metal base supports
- 10-YEAR WARRANTY on Wood2Wood oak foundations

GALVANISED STEEL FOUNDATION

Our standard playground is supplied with galvanized steel foundations.



The use of top quality materials, such as for example larch wood, colour coat sheets, plastic and rubber, stainless and galvanised steel and steel-covered rope combined with first class production methods give our playgrounds great durability and makes them look inviting for many years.



The PE plates that we use in our playgrounds are made in a variety of colors, so you can choose the color set that you like the most. Visit our website to find out more.



Wooden posts are delivered with plastic caps safeguarding against weather conditions.



The plastic components used in our climbing nets are designed to last. Combined with our use of steel reinforced rope, help safeguarding against vandalism and exceptionally hard use.



Our climbing stones are made of rubber. Their porous surface prevents fingers from slipping. Our climbing walls are made of 18 and 22 mm thick waterproof plywood, with a thin layer of strong and weather resistant laminated surface.

The metal foundations of the wooden posts should be installed about 57 to 77 cm into the ground and end about 3 cm above the ground level.

A long lasting steel connection - inherently resistant to corrosion.





7

Pyramid roofs are made of colorful UV resistant fiberglass, which is unaffected by weather conditions and requires no service.



8

Our plastic tube tunnels, with a diameter of 630 mm and wall thickness of 12 mm, are almost unbreakable.



9

Our panel sheets have a thickness of 0,5 - 0,8 mm and they are galvanized and covered with plastisol. Owing to that, they have a minimum 20-year lifespan and keep the playground colorful and inviting in its whole lifetime. Furthermore they require absolutely no maintenance.



10

7

8

9

11

12

In our colorful and solid slides we use stainless steel for the sliding surface and polyethylene plate for the sides.

All wooden elements are planed, all edges are rounded and all screws and bolts are either countersunk or covered with plastic caps.

Panel sheets are fastened to the post with special anticorrosive screws with a rubber washer.



10



11



12

DISCOVERY



10851 DIXIE

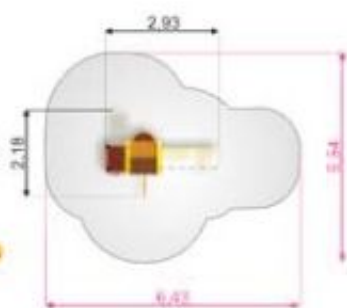

1:200

10850 PIXIE

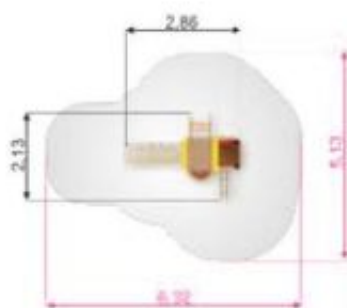
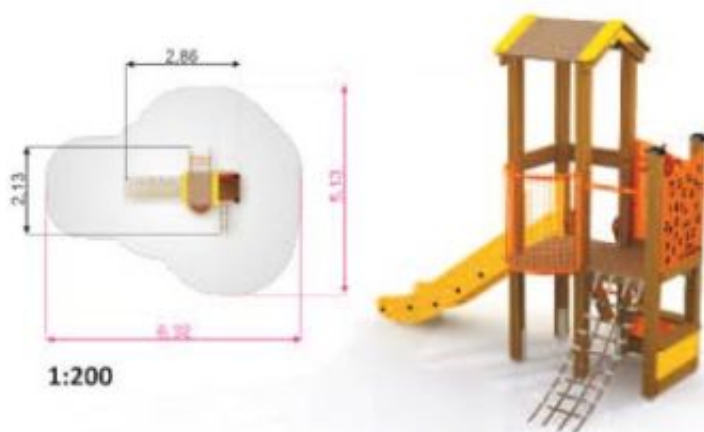

1:200

10856 SMART

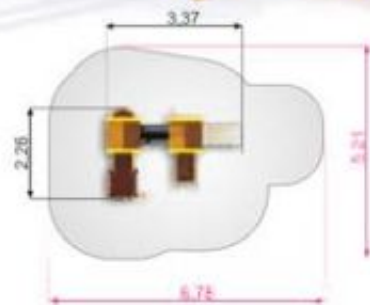

1:200

10857 RUBIK

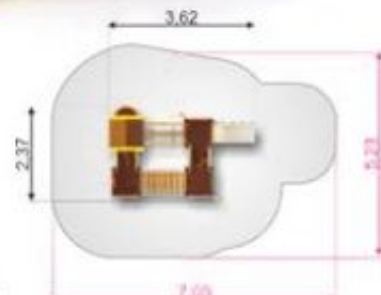

1:200

10855 BRAVO

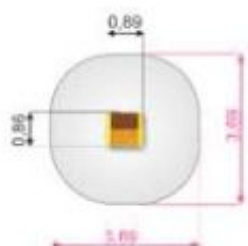

1:200

10852 NEMO

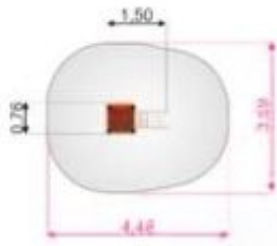

1:200

10853 PI

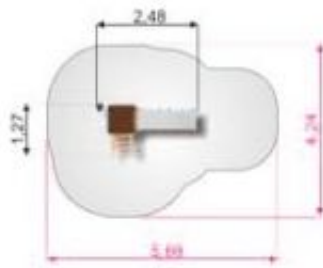

1:200

10854 SIGMA

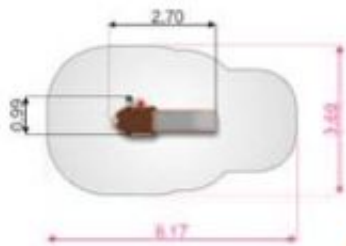
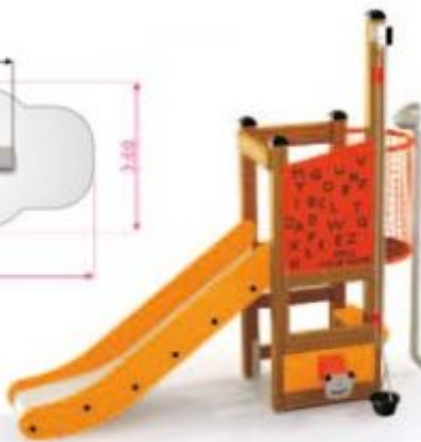

1:200



10770 ALPHA

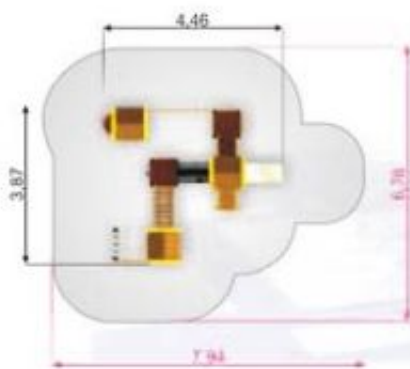

1:200



10766 MINI PLAY

-  1+
-  1,56 m
-  0,55 m
- W2W
METAL
-  8,5 h

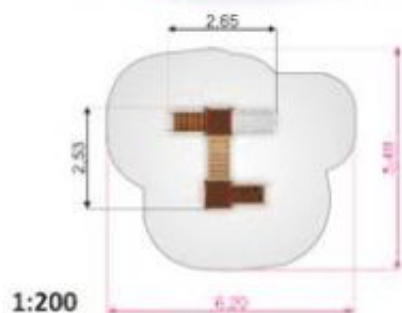

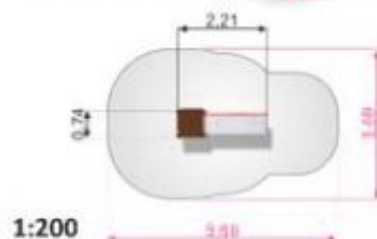

10759 TODDLER TOWER SLIDE

-  3+
-  1,86 m
-  0,90 m
- W2W
METAL
-  3 h





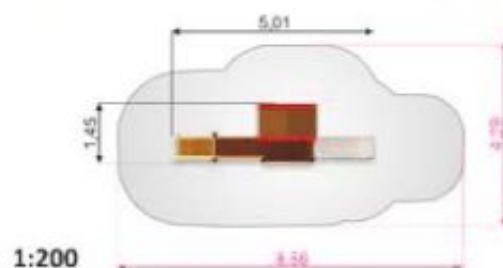

10751 COUNTRY HOUSE

-  3+
-  2,84 m
-  0,90 m
- W2W
METAL
-  8 h



10765 FORTRESS

-  1+
-  2,37 m
-  0,55 m
- W2W
METAL
-  9 h

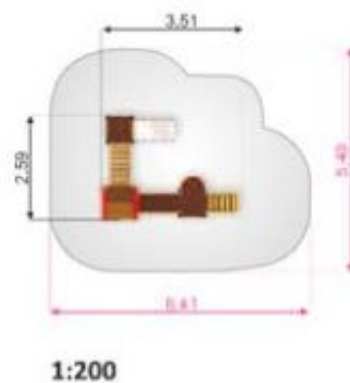



10761
KNIGHT'S CASTLE

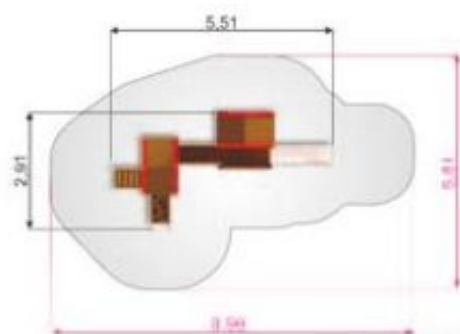

1:200



- 3+
- 2,84 m
- 0,90 m
- W2W
METAL
- 8,5 h

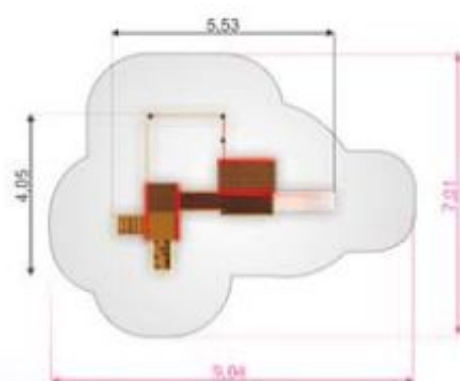

1:200







10762
TOWER

- 3+
- 2,84 m
- 1,45 m
- W2W
METAL
- 9,5 h





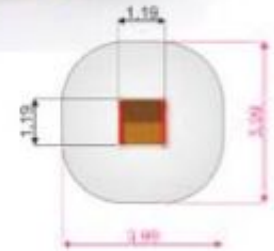

10708
THE PLAYHOUSE

-  1+
-  2,15 m
-  0,30 m
-  W2W
-  2,5 h



1:200

10712
THE VERANDA HOUSE

-  1+
-  2,05 m
-  0,15 m
-  W2W
-  4 h

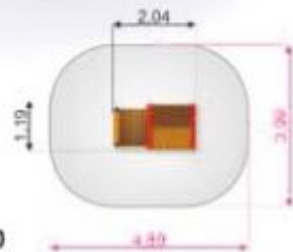

1:200

10724
THE VILLA



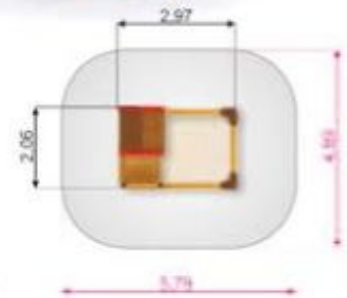

-  1+
-  2,15 m
-  0,38 m
-  W2W
-  6 h



1:200



10720
THE PLAYHOUSE

-  1+
-  2,45 m
-  0,55 m
-  W2W
-  5 h

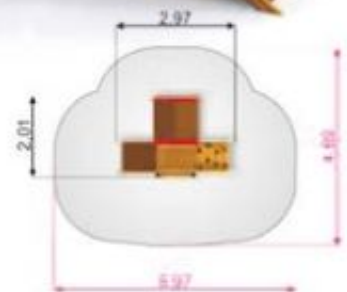

1:200

11283 CLOCK



W2W
METAL

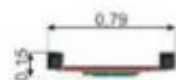

1:50

11282 MEMORY



W2W
METAL



1:50

11281 TIC TAC TOE



W2W
METAL

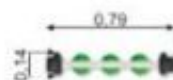

1:50

11285 MEGAPHONE

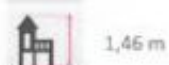

W2W
METAL

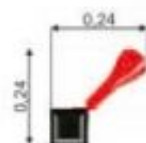

1:20



11400 CAMEL



W2W



3+

1,64 m

0,90 m

2,5 h

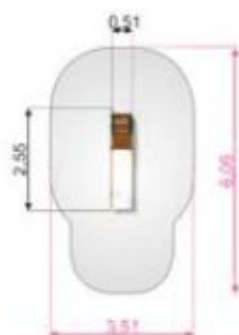

1:200

11404 ELEPHANT



W2W
METAL



3+

3,21 m

1,20 m

5,5 h

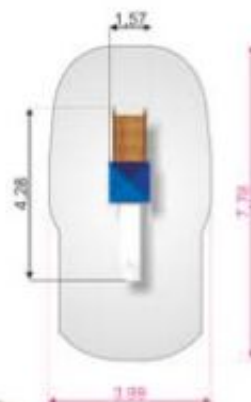

1:200

11255

SEAL

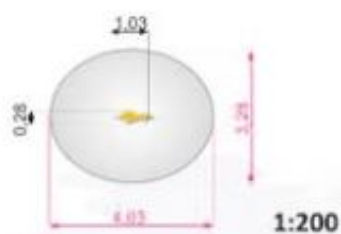

11253

ROOSTER

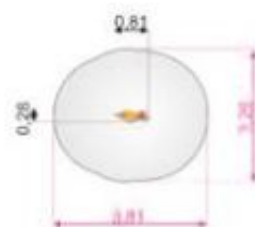

11261

PONY

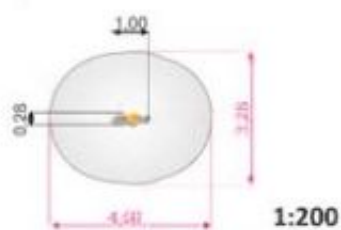

11265

GIRAFFE

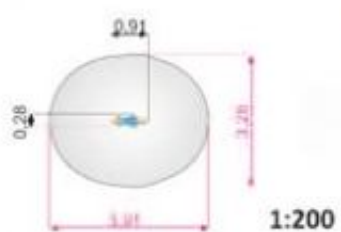

11252

RABBIT

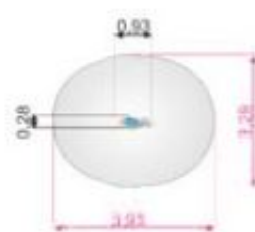

11248

SCOOTER

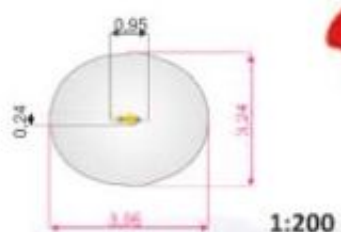

11251

DOGGY

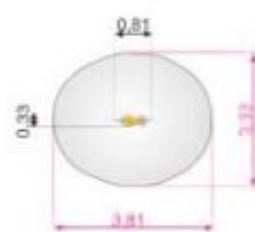

11250
DOG SPRING

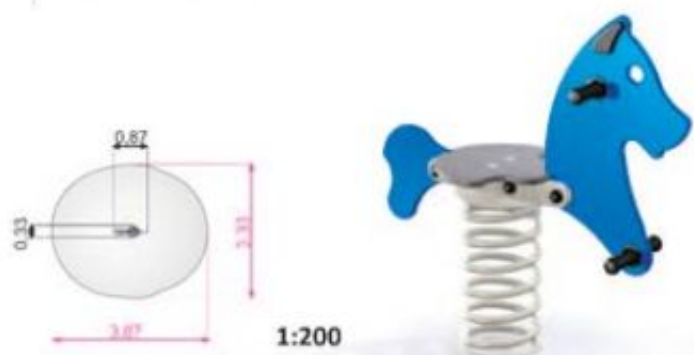

1:200

11254
PONY SPRING

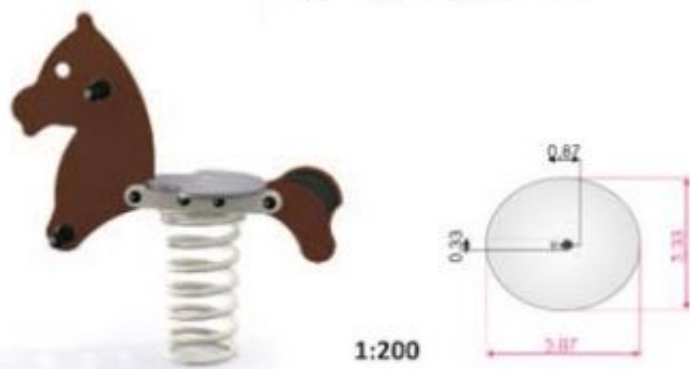

1:200

11256
SEAL SPRING



1:200

11257
WALRUS SPRING



1:200

12221
BIRD SWING

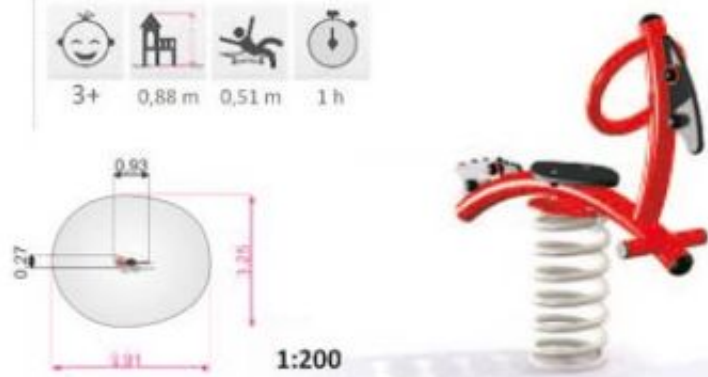

1:200

12220
YACHT



1:200





12165
MINI BALANCE

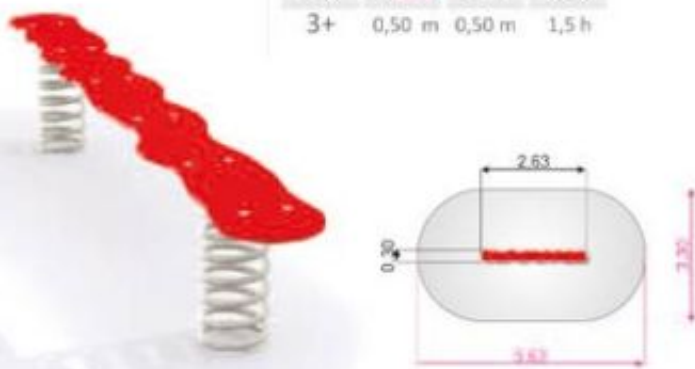

12166
BALANCE



17112
TURTLE SPRING

-  2+
-  0,81 m
-  0,50 m
-  1 h

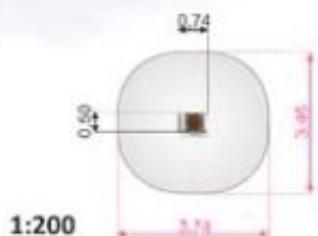



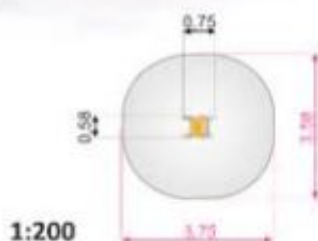

11258
CAR

-  2+
-  0,83 m
-  0,51 m
-  1 h



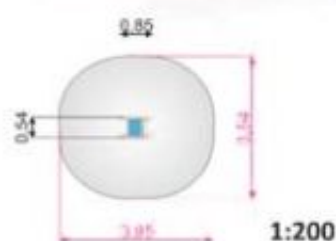

11259
WHALE

- 2+ 
- 0,82 m 
- 0,51 m 
- 1 h 





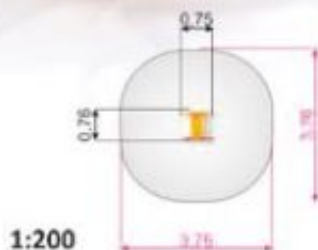

11268
DOUBLE AUTO SPRINGER

-  2+
-  0,83 m
-  0,51 m
-  1,5 h



11275
BULLDOZER

- 2+ 
- 0,83 m 
- 0,51 m 
- 1 h 

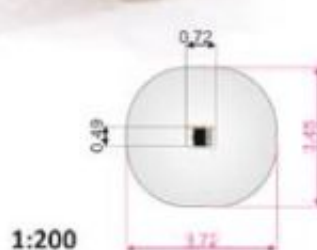

11249

CLOVER



3+



0,58 m



0,66 m



1,5 h

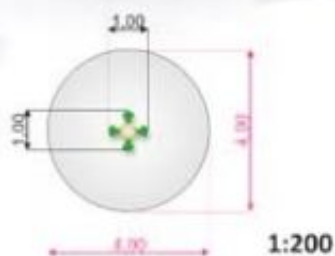

1:200

11260

DOUBLE PONY SPRING

3+



0,90 m



0,51 m



2 h

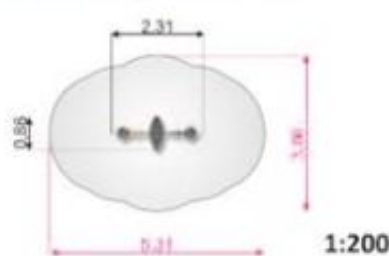

1:200

11263

TRIPLE WALRUS SPRING



3+



0,81 m



0,51 m



2 h

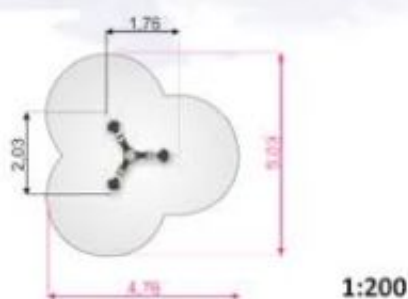

1:200

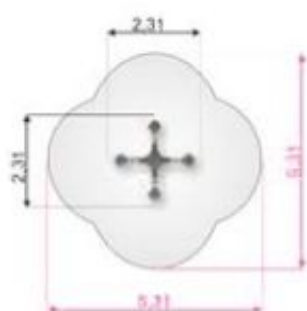

1:200

11264

QUADRO WALRUS - SEAL SPRING

3+



0,81 m



0,51 m



2 h



10738

LOCOMOTIVE

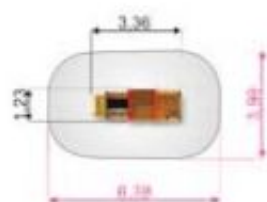

1:300



10736

LOCOMOTIVE WITH SLIDE

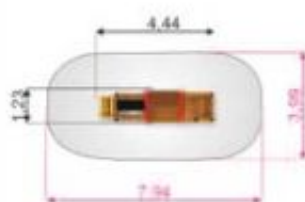

1:300



10742

TRAIN



1:300

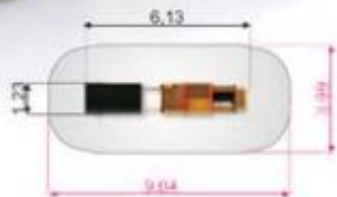

10737

LOCOMOTIVE WITH CARS



1:300

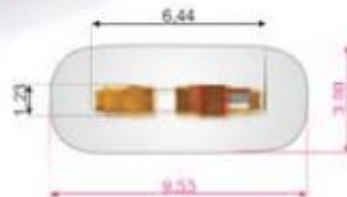

11423
SMALL SHIP

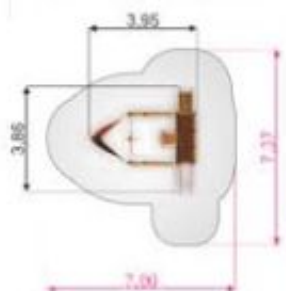

1:300



11424
FISHER BOAT

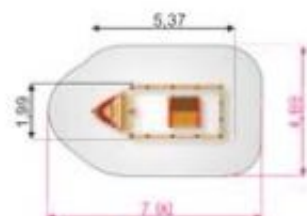

1:300



11425
SHIP

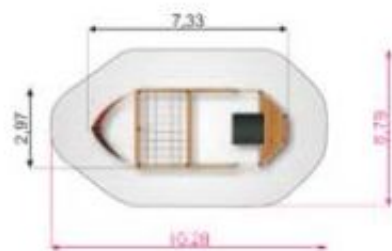

1:300



FARM

11270
COW

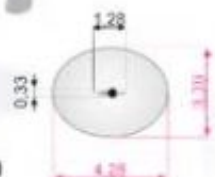

1:300

11271
SHEEP

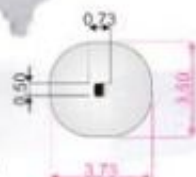

1:300

11274
PIGGY



1:300

11273
MINI TRACTOR SPRINGER

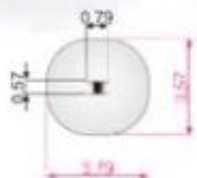

1:300

10745
TRAKTOR

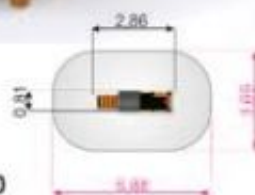

1:300

10744
TRAKTOR WITH TRAILER

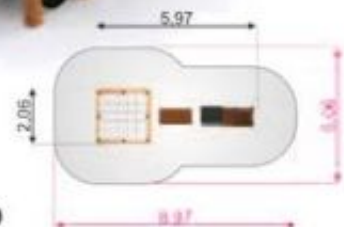

1:300

11278
CAR TRAILER

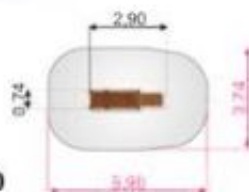

1:300



20007-1

VILLA WITH ORCA

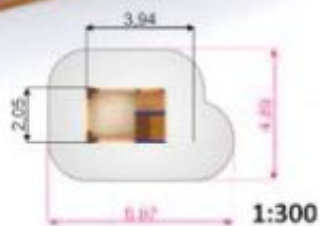

20008-1

SMALL SHIP WITH DOLPHIN

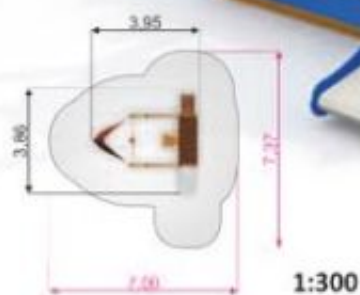

20006

DOLPHIN SLIDE

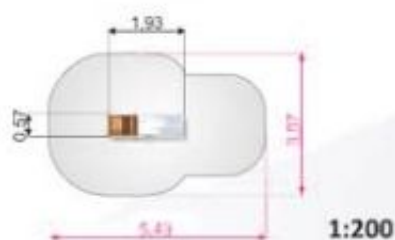

FIRE BRIGADE

10870

FIRE-STATION



3+ 2,61 m 1,75 m 5 h

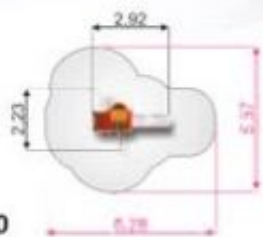

1:300

10875

FIRE BRIGADE CAR



1+ 1,91 m 0,30 m 6,5 h

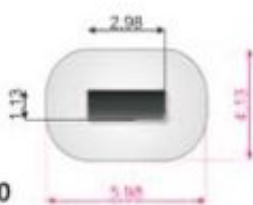

1:300

10890

FIRE BRIGADE TRUCK



1-3 1,11 m 0,21 m 2 h

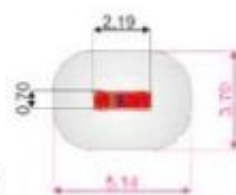

1:300





POLICE

10871

POLICE STATION



3+ 2,61 m 1,90 m 5 h

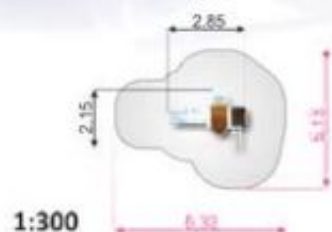

1:300

10876

POLICE TRUCK



1+ 1,91 m 0,30 m 5 h

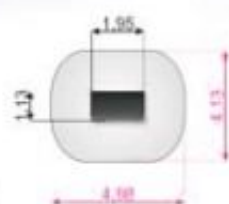

1:300

10891

POLICE CAR



1-3 1,11 m 0,21 m 2 h

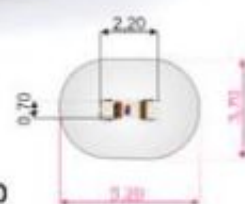

1:300



10892
TAXI

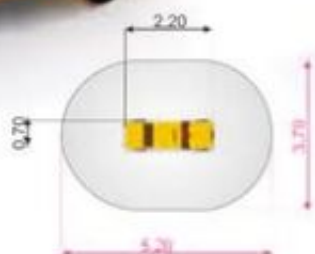

1:200

10746
BUSS

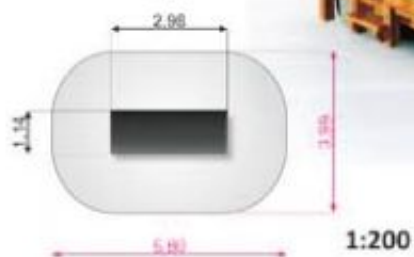

1:200

10893
TRUCK

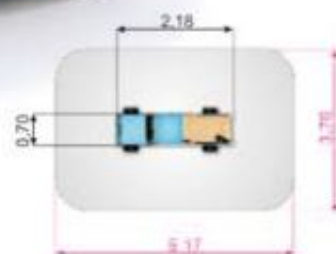

1:200



ALL ACCESSIBLE



10771

BETA - ALL ACCESSIBLE PLAYGROUND

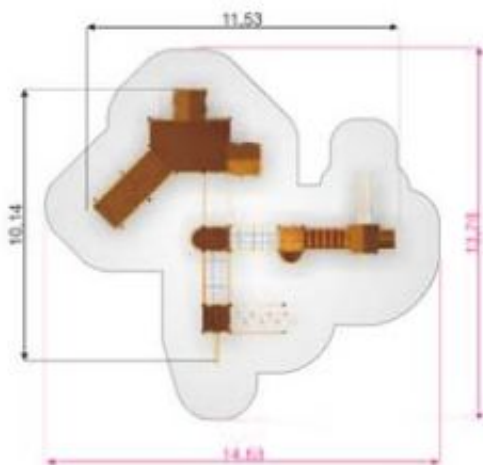

1:300



10858

TRIXIE - ALL ACCESSIBLE PLAYGROUND

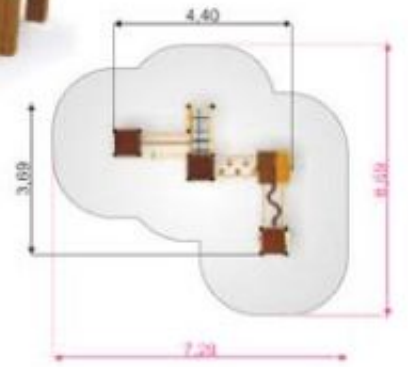

10727

ALL ACCESSIBLE SANDBOX

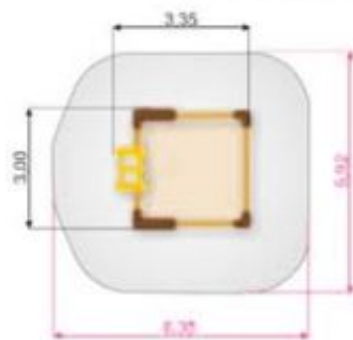

10769

ALL ACCESSIBLE PLAYGROUND

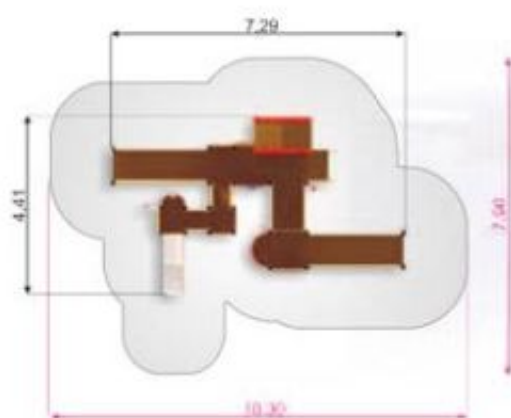

10775

CAMPANILLE - ALL ACCESSIBLE PLAYGROUND

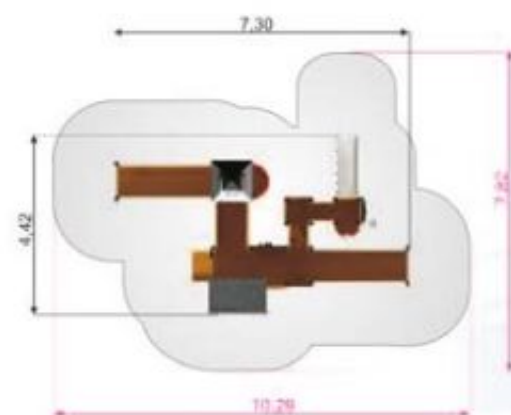

SWINGS



11100 SINGLE SWING

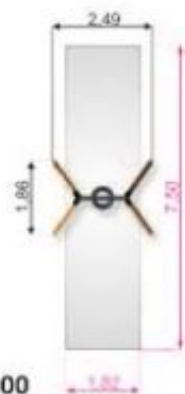

1:200

11101 SAFETY SEAT SWING

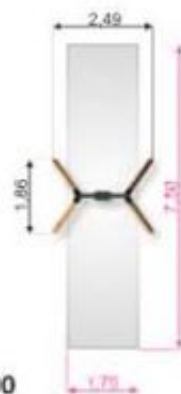

1:200

11102 BABY SWING

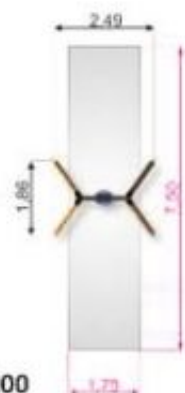

1:200

11104 FLEXI SEAT SWING



1:200

11120
DOUBLE TYRE SWING

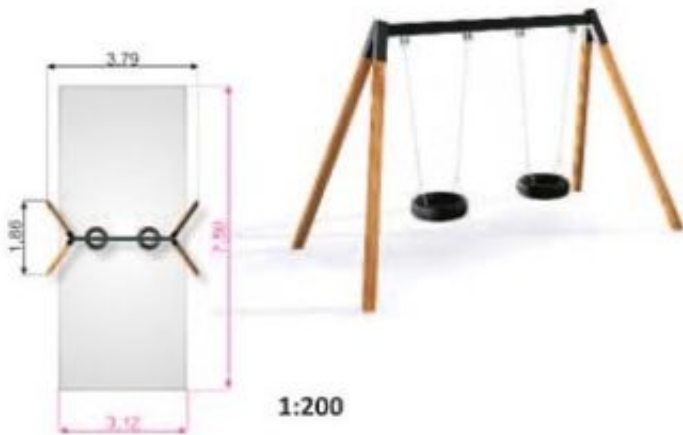

11121
DOUBLE SAFETY SWING



11122
DOUBLE BABY SWING

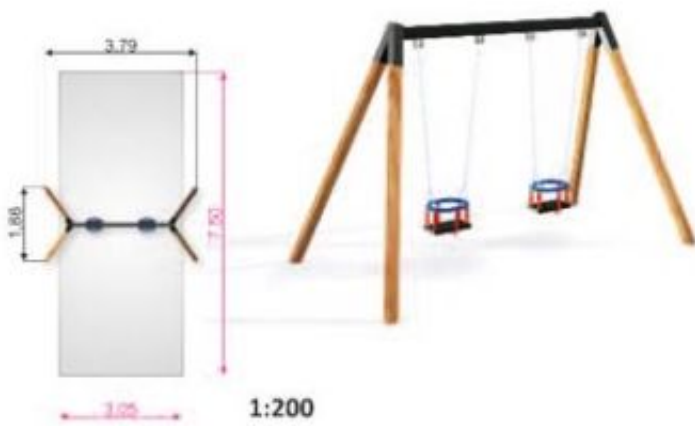

11123
DOUBLE SWING

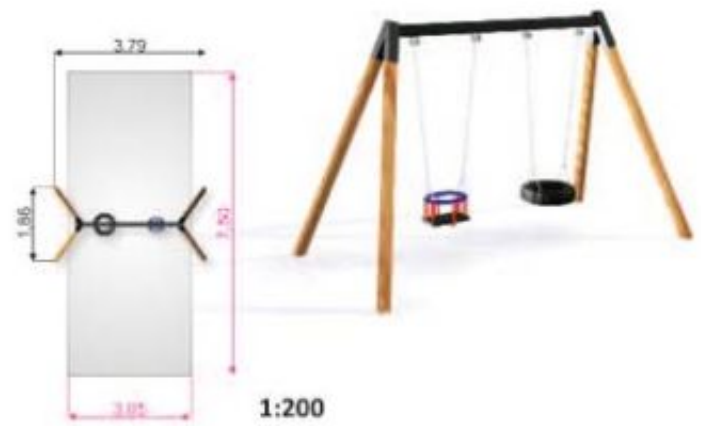
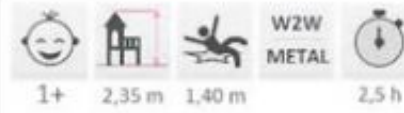

11130
DOUBLE SWING 1+1

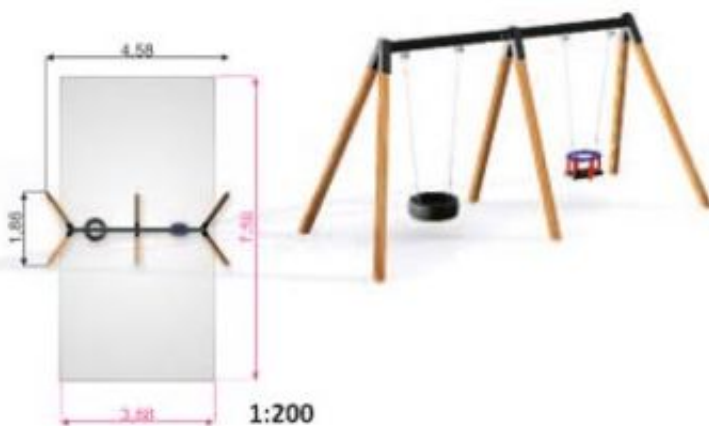

MODIFICATION

11103

SWING (BIRD NEST)



3+



2,35 m



1,35 m

W2W
METAL



2,5 h



ø 90



ø 120

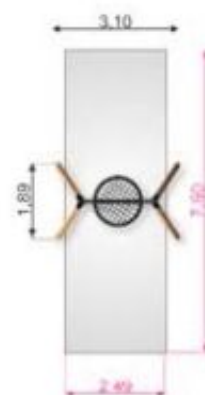

1:200



11131
DOUBLE SWING (BIRD NEST)

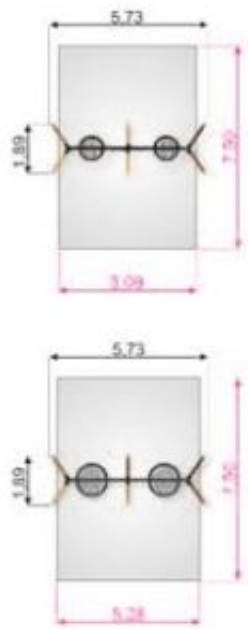

Ø 90

1:300

Ø 120



3+



2,35 m



1,35 m



W2W
METAL

3 h



11185
TRIPLE SWING

Ø 90

Ø 120



3+



2,35 m



1,40 m

W2W
METAL



3 h

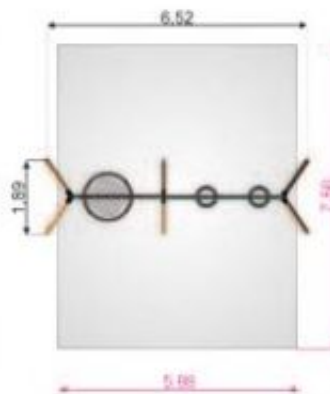
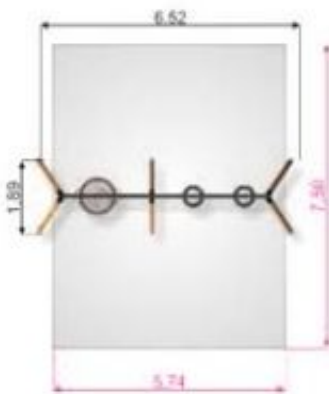

1:200



11182

1+2 SWING

- 1+
- 2,35 m
- 1,40 m
- W2W
METAL
- 3 h

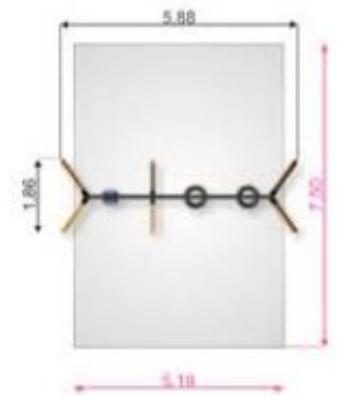

1:200



11180

2+2 SWING

- 1+
- 2,35 m
- 1,30 m
- W2W
METAL
- 3 h

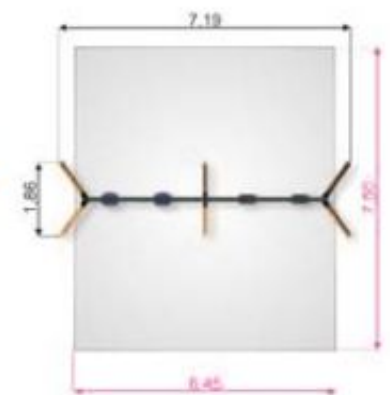

1:200

11140
WOODEN TYRE SWING



1:200



3+



2,48 m



1,35 m



W2W



2,5 h



11189
SIX ARM SWING

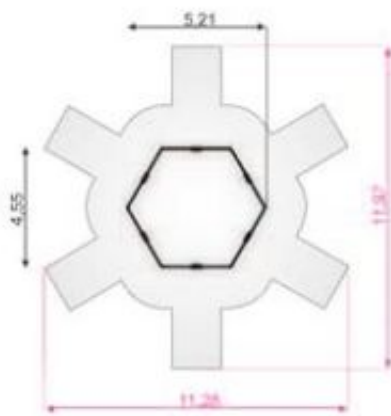

1:200



3+



2,40 m



1,26 m



W2W

METAL

5 h



13060

BNS SWING ROBINIA 2 POSTS



3+ 1,59 m 1,00 m 2,5 h



1:200

13025

FLEXI SIT SWING



3+ 1,60 m 0,91 m 2,5 h



1:200



13027

HAMMOCK



3+ 1,50 m 1,26 m 2,5 h



1:200

13024

DOUBLE SWING



3+ 2,40 m 1,40 m 2,5 h



1:200

13022

NATURE SWING



1+ 2,40 m 1,30 m 2,5 h



1:200

13023
SWING

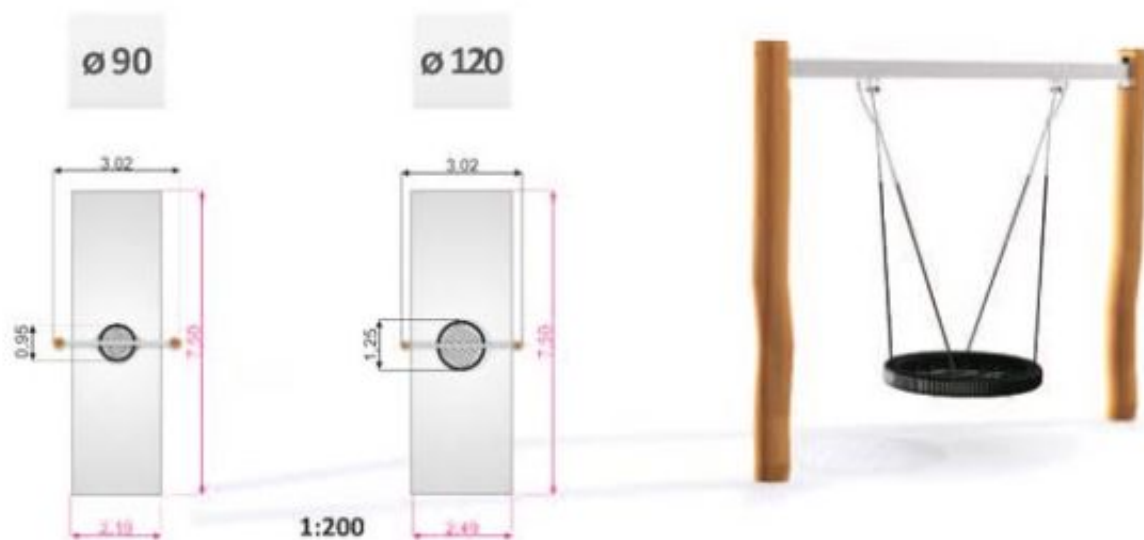

- 3+
- 2,40 m
- 1,35 m
- 2,5 h



13062
BNS SWING ROBINIA 4 POSTS

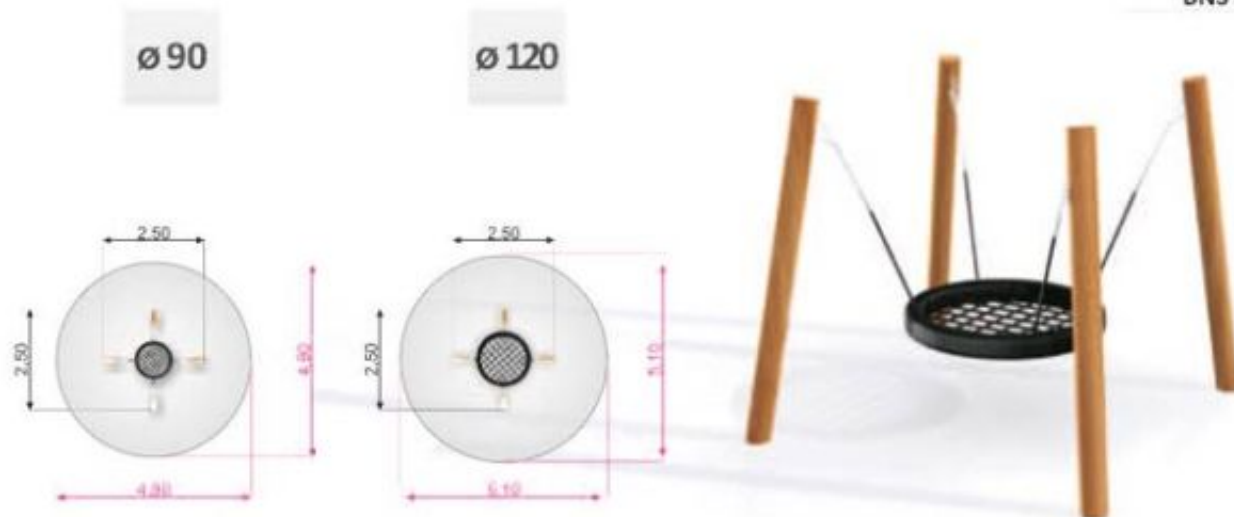

- 2+
- 1,59 m
- 0,55 m
- 3,5 h

1:200

12161

SINGLE SILVER SWING



1:200



12162

DOUBLE SILVER SWING



1:200



12168

TORNADO SWING



1:300

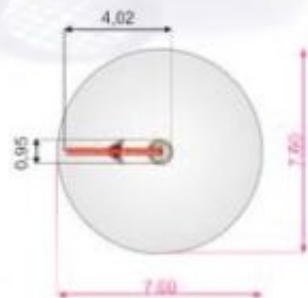

MODIFICATION

12103

SILVER SWING BNS



ø 90

ø 120



1:200

17402
SINGLE SWING SOLARIS



17401
SINGLE SWING SOLARIS



17403
DOUBLE SWING SOLARIS



17404
DOUBLE SWING SOLARIS



12300
BABY SWING



12160
YOUTH SWING

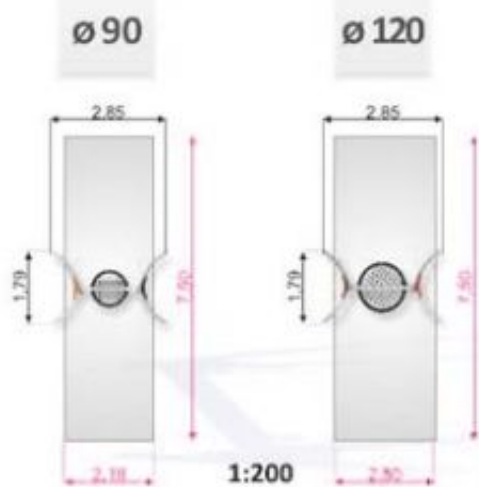

17405
SWING SOLARIS BNS



50028
WHEELCHAIR SWING

-  1+
-  2,61 m
-  1,30 m
-  3 h

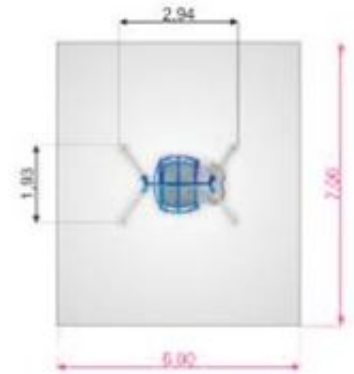

1:200

12080
HAMMOCK

-  3+
-  1,45 m
-  1,20 m
-  2 h

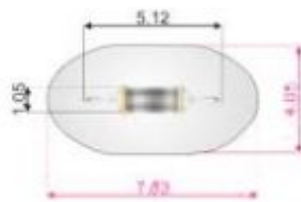

1:300



17406
BNS SWING 3 POSTS

-  3+
-  2,56 m
-  1,50 m
-  2,5 h



1:300



17101
SWING

-  3+
-  3,00 m
-  1,30 m
-  2,5 h



1:200



17100
HAMMOCK

-  3+
-  2,70 m
-  0,55 m
-  2 h

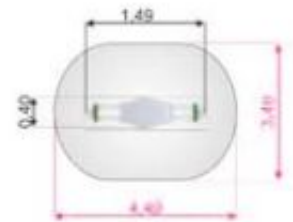

1:200



20051

BUFFER (SEPARATOR FOR SWINGS)



1,5 h



20052

BUFFER (SINGLE UNIT)



1 h



TS • TSPF*
TIRE SEAT

*PAH-free



SS
SAFETY SEAT



BNS90 • BNS120
BIRD NEST SEAT



TBS
TIRE BABY SEAT



FS
FLEXI SEAT



BS
BABY SEAT



SAS
SWING SEAT SAS



GBNS
SWING SEAT GBNS



SAND & WATER PLAY



13038
TRIANGLE



1:200



13039
5 - ANGLE PALISADE BOX

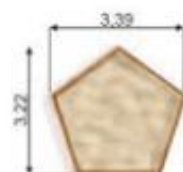

1:200



13032
PALISADE HORIZONTAL

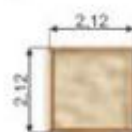

1:200





10700 SANDBOX



Also available in modular sizes:
3x3 m, 4x4 m, 3x4 m etc.

10860 SANDPIT

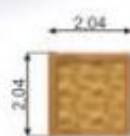

1:200



20050 DINO SANDBOX BASE



20050 + 10860



20050 + 10700



20050 + 19700





13031 SAND EDGING PEGS 40 cm (RM)

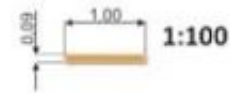

13037 SAND EDGING BOARDS 60 cm (RM)

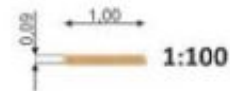

13050 SANDBOX

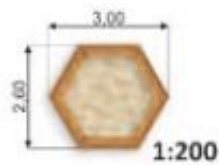

13033 PALISADE HORIZONTAL



13035 LARCH BEAM (RM)



13036 LARCH BOARD SECTION (RM)



13030 LARCH BOARD SECTION LOW



13034 OAK BEAM SECTION (RM)





10733 SAND & WATER PLAY TABLE

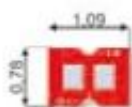

10734 SAND & WATER PLAY TABLE II

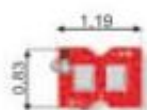

1:100



10735 SAND & WATER PLAY

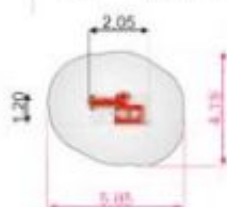

1:300



10731 SAND & WATER PLAY

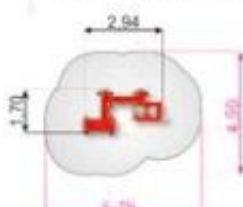

1:300

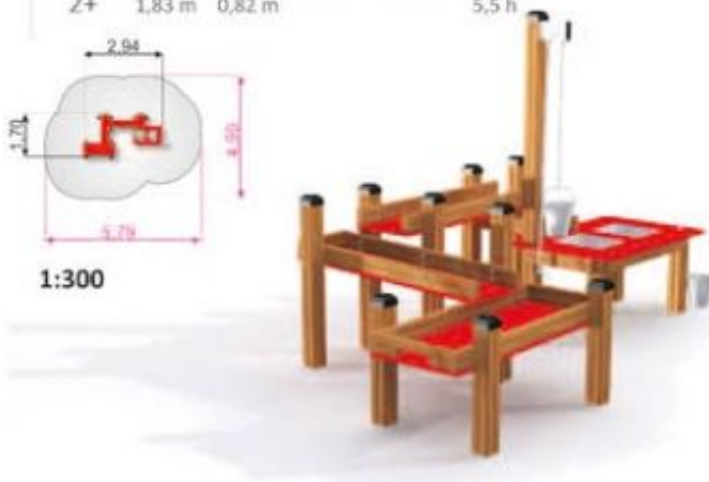

10895
EXCAVATOR



A: 0,23 m 1,15 m 1 h
B: 1,40 m

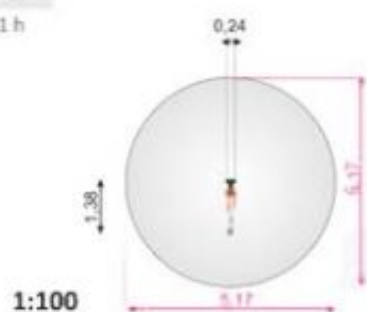

1:100



12353
SQUARE BENCH AND TABLE



1+ 0,45 m 0,45 m 2 h

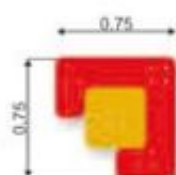

1:50



12351
TABLE AND CHAIR



1+ 0,45 m 0,45 m 1,5 h

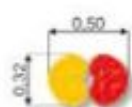

1:50



12357
TRIANGLE SEAT AND TABLE



1+ 0,47 m 0,47 m 2 h

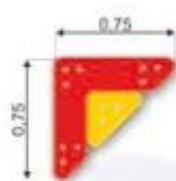

1:50



12362
HEART TABLE



1+ 0,45 m 0,45 m 1 h

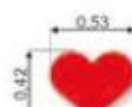

1:50



12365
OCTOPUS TABLE WITH BASINS



1+ 0,73 m 0,45 m 2 h

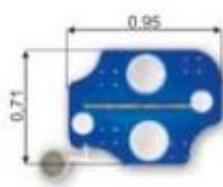

1:50



12359

DAISY

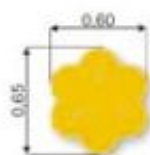

1:50



12354

SAND - WATER TABLE

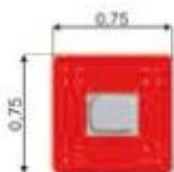

1:50



12366

BUTTERFLY TABLE

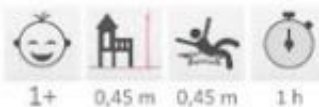

1:50



12361

BUTTERFLY TABLE WITH BASINS

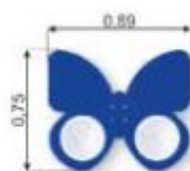

1:50



12363

CLOVER TABLE

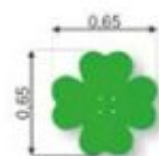

1:50



12364

CLOVER TABLE WITH BASINS

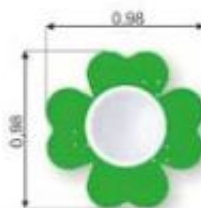

1:50



CLASSIC NATURE



19423

SMALL SHIP NATURE



1+ 2,16 m 0,55 m 8 h

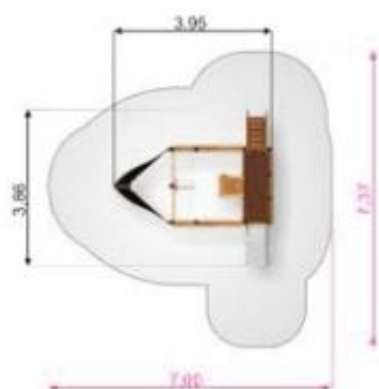

1:200



19425

SHIP NATURE



3+ 3,03 m 1,08 m 9 h

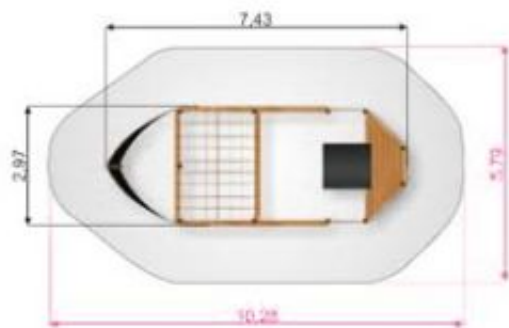

1:200



19746

BUS NATURE

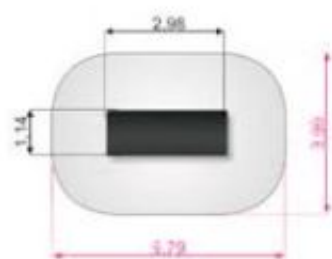

1:200



19738

LOCOMOTIVE NATURE

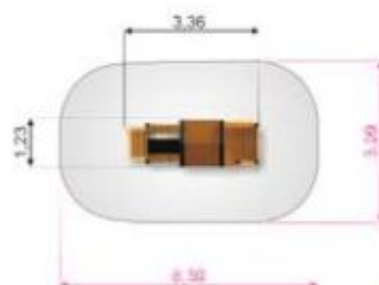

1:200



19737

LOCOMOTIVE WITH CARS NATURE

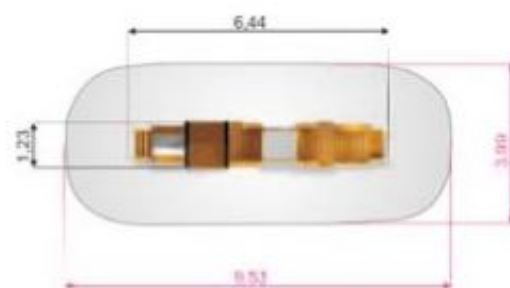

1:200

19708

PLAYHOUSE NATURE

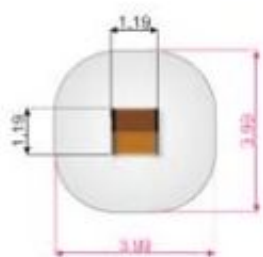

1:200

19724

WILLA NATURE

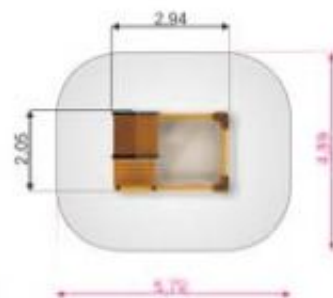

1:200



19720

PLAYHOUSE NATURE

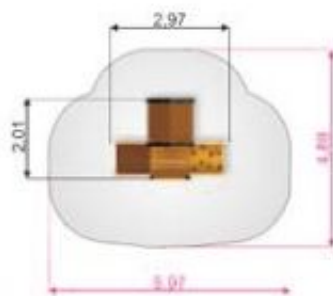

1:200

19712

VERANDA HOUSE NATURE

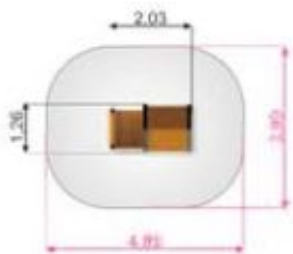

1:200



19751

COUNTRY HOUSE NATURE



3+



2,50 m



0,90 m

W2W
METAL



5,5 h

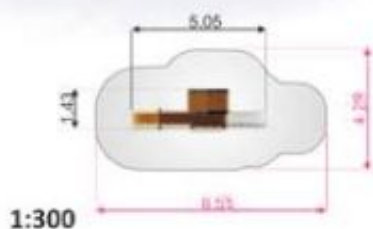

1:300

19761

KNIGHT'S CASTLE NATURE

3+



2,84 m



0,90 m



W2W
METAL



8,5 h

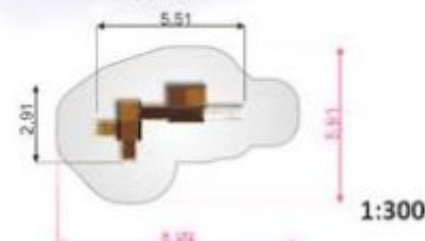

1:300

19762

TOWER NATURE



3+



2,55 m



1,45 m

W2W
METAL



9,5 h

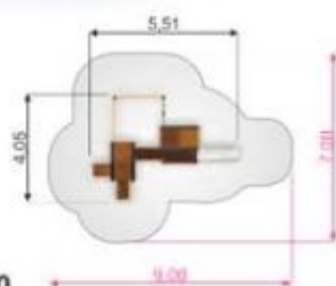

1:300



19765

FORTRESS NATURE

3+



2,07 m



0,55 m



W2W
METAL

9 h

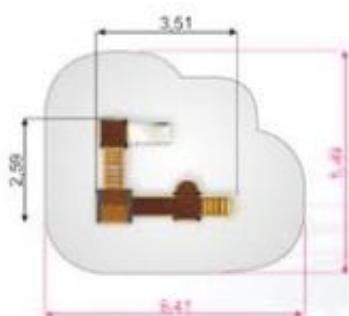

1:200



19780 THESEUS

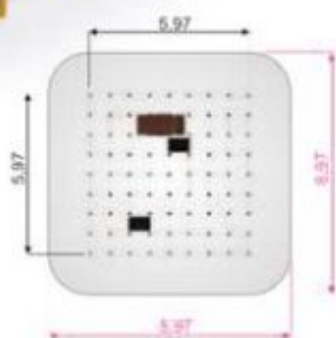
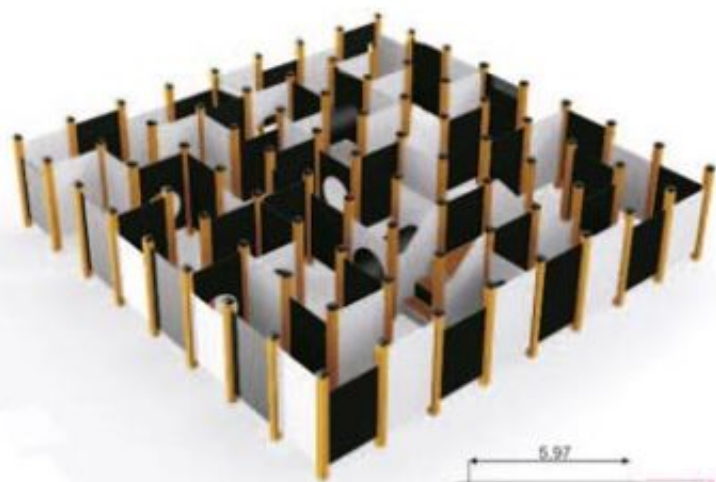

1:300

19781 ARIADNE

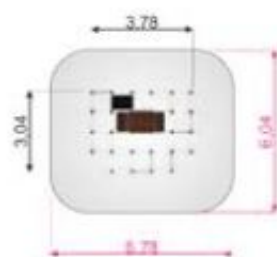

1:200



19148 CLIMBING KIOSK NATURE

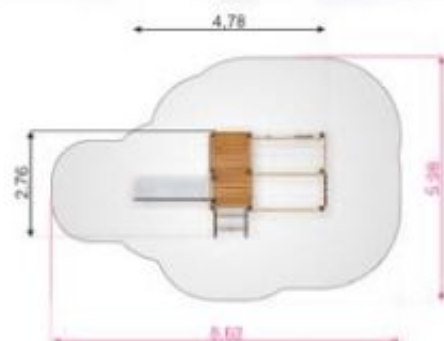

1:200

19147

LITTLE JUNGLE NATURE



3+



2,16 m



2,05 m



W2W
METAL



7,5 h



1:200



19100

LOGO TOWER NATURE



3+



2,13 m



1,20 m



W2W
METAL



4 h

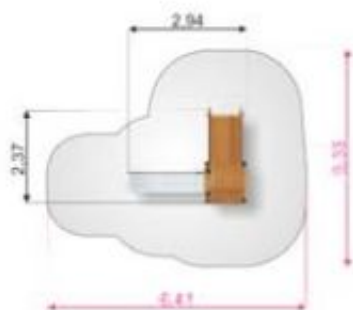

1:200

19168

SIX ANGLE AZTEC



3+



3,50 m



2,35 m



W2W
METAL



10 h

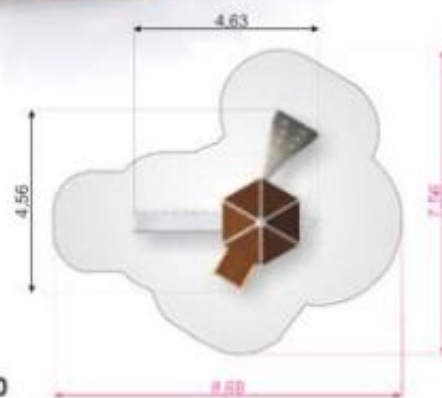

1:200

19600

CLIMBING BOOTH NATURE



3+



2,75 m



2,65 m



W2W
METAL



10 h

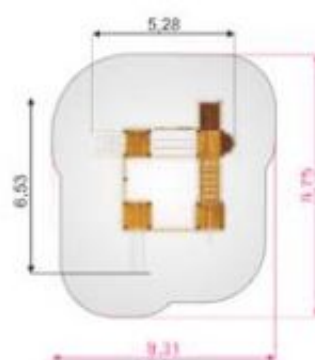

1:300



19333

ROMPING CORNER NATURE



3+



2,46 m



2,35 m



W2W
METAL



10 h

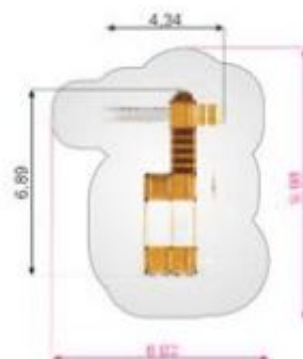

1:300

19242
SPIDERMAN

3+



2,76 m



2,35 m



W2W
METAL

8,5 h

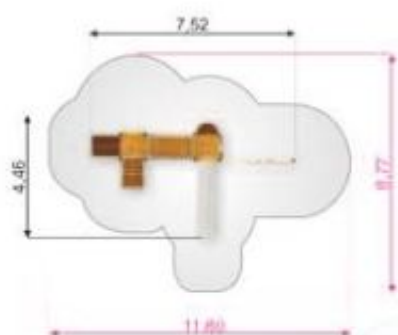

1:300



19240

ROMPING CENTER NATURE

3+



2,16 m



2,05 m



W2W
METAL

8,5 h

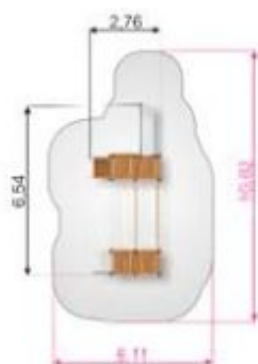

1:300



19265
GORILLA NATURE



3+



2,16 m



2,05 m



8,5 h

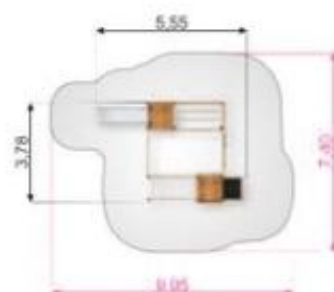

1:300

19405
CHALLENGER NATURE



3+



2,46 m



2,23 m



12 h

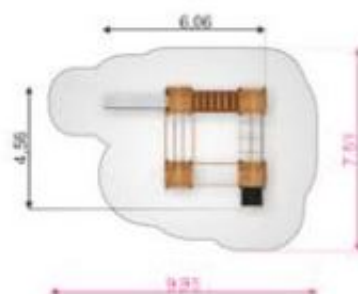

1:300

19415
CHALLENGER AZTEC



3+



2,46 m



2,22 m



11 h

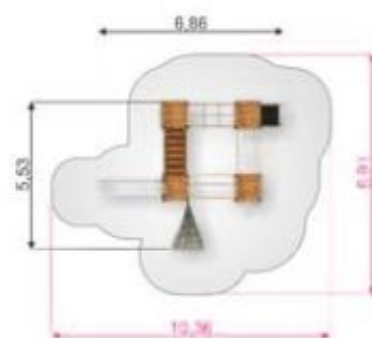

1:300

19416

CHALLENGER AZTEC NATURE II

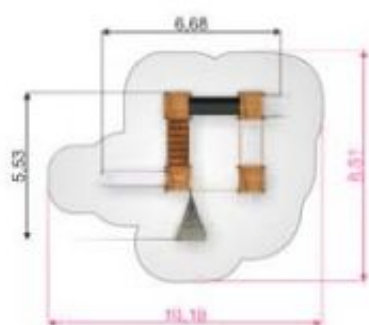

1:300



3+



2,46 m



2,00 m



W2W
METAL

12 h



19410

SQUARE PLAY NATURE

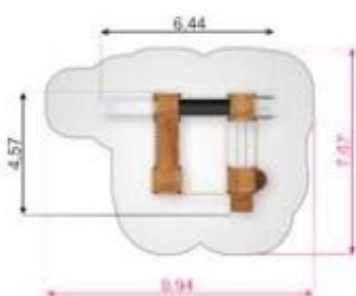

1:300



3+



2,16 m



2,05 m



W2W
METAL

12 h



19530
SEAROBBER CASTLE



3+



2,73 m



1,80 m

W2W
METAL



17 h

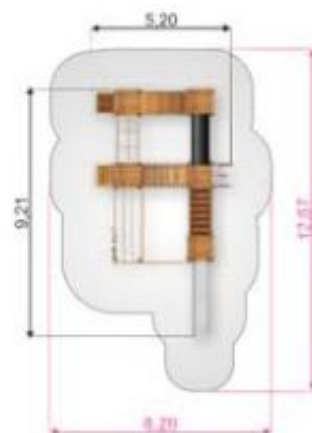

1:300

19320
MOTOR FUNCTION CENTER NATURE



3+



2,73 m



2,50 m

W2W
METAL



11 h

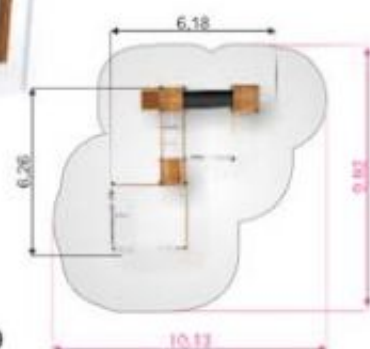

1:300



19540
KING-KONG NATURE

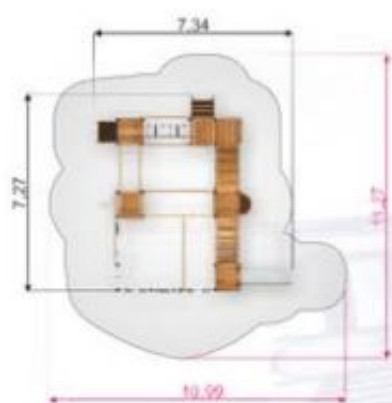

1:300



- 3+
- 3,33 m
- 2,10 m
- W2W
METAL
- 17 h



19541
KING- KONG NATURE II

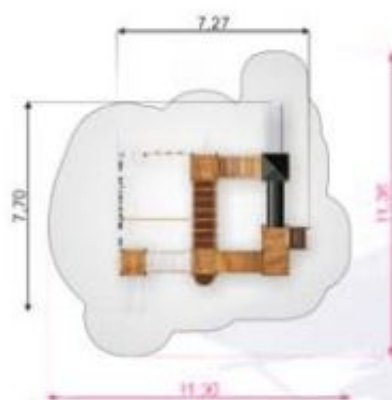

1:300



- 3+
- 3,33 m
- 3,00 m
- W2W
METAL
- 17 h



19594
MASTODONT



3+



3,23 m



2,70 m



W2W



23 h

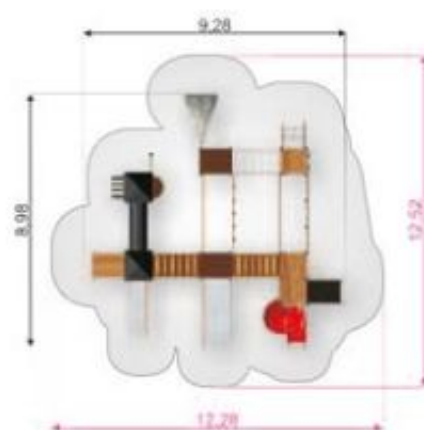

1:300



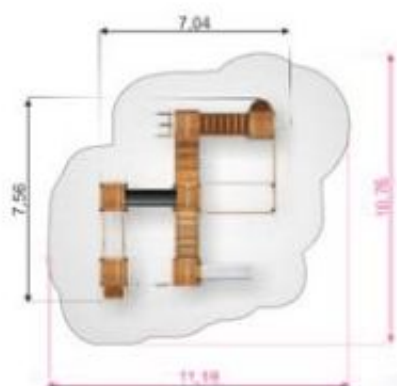

1:300



19550
TRITOWERS NATURE

- 3+
- 2,73 m
- 2,65 m
- W2W
METAL
- 18 h

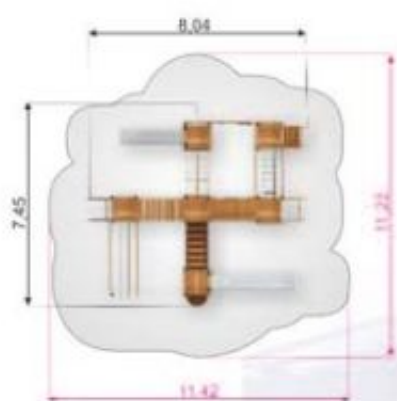

1:300



19592
SPACE STATION NATURE

- 3+
- 3,03 m
- 2,35 m
- W2W
METAL
- 18 h

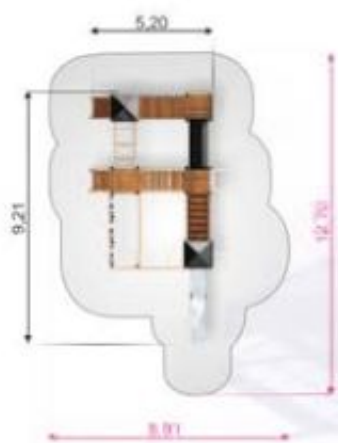

1:300



19532
EXPLORER

- 3+
- 3,80 m
- 2,65 m
- W2W
METAL
- 19 h

PIONEER



10250 TWISTER



3+



4,13 m



2,45 m



W2W
METAL



10 h

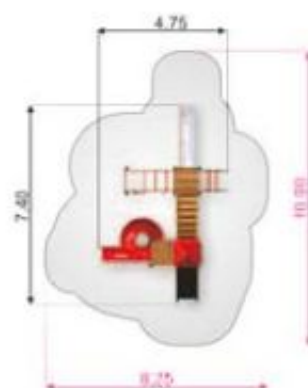

1:300

10330 LEMUR



3+



2,93 m



2,05 m



W2W
METAL



5 h

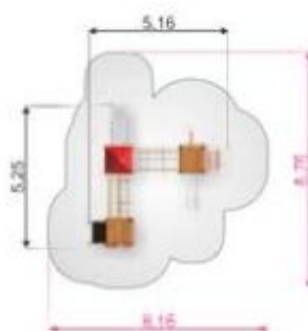

1:300

10240
ROMPING CENTER

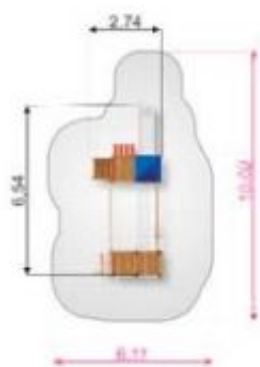

1:300



3+



3,20 m



2,05 m



W2W
METAL

8,5 h



10415
CHALLENGER- AZTEC

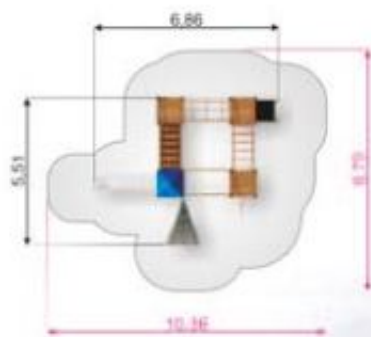

1:300



3+



3,53 m



2,36 m



W2W
METAL

11 h



10265 GORILLA

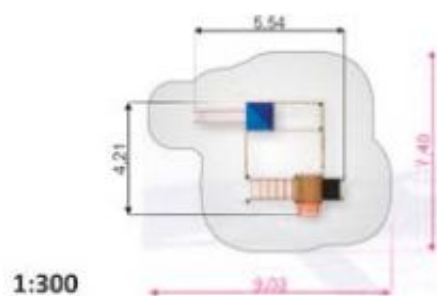

10405 CHALLENGER

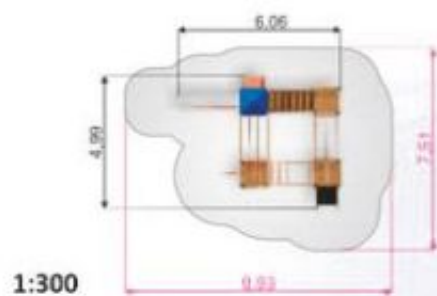

10406
JUBILEE UNIT

			W2W METAL	
3+	3,50 m	2,05 m		12 h

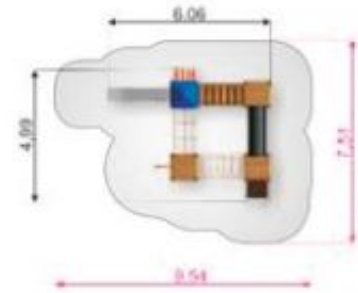

1:300



10410
SQUARE PLAY

			W2W METAL	
3+	3,23 m	2,05 m		12 h

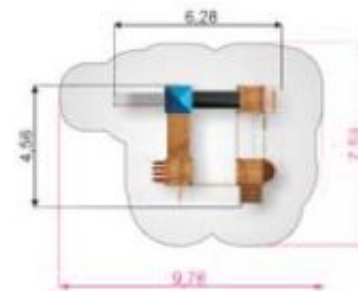

1:300

10167

MAST



W2W
METAL



3+

3,96 m

1,80 m

4 h

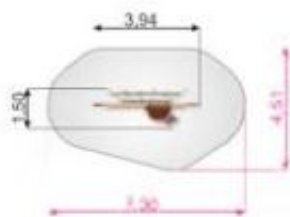

1:300



10168

SIX ANGLE WITH SUSPENSION BRIDGE



W2W
METAL



3+

3,20 m

2,05 m

10 h

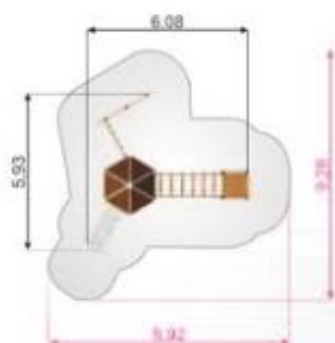

1:300



10166

THE SIX ANGLE



W2W
METAL



3+

3,19 m

2,35 m

9 h

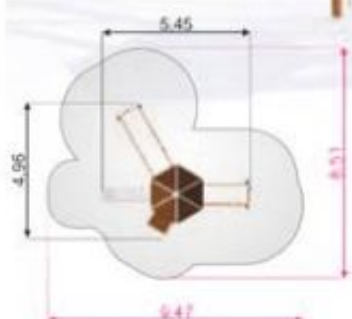

1:300



10171

SINGLE SWING WITH TOWER

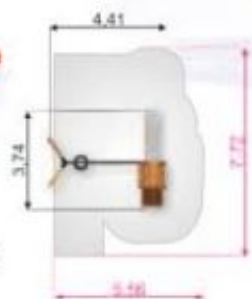

1:300

10173

SINGLE SWING WITH TOWER

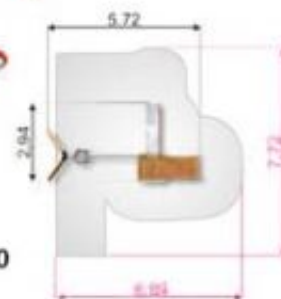

1:300



10172

DOUBLE SWING WITH TOWER

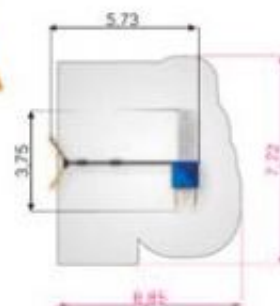

1:300



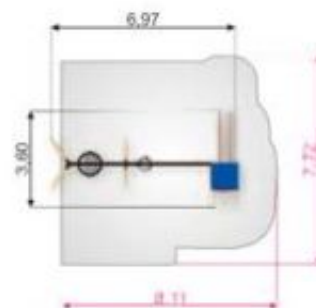

10174

BIRD NEST SWING WITH TOWER



1:300

10147
LITTLE JUNGLE

-  3+
-  2,13 m
-  2,05 m
- W2W
METAL
-  7,5 h

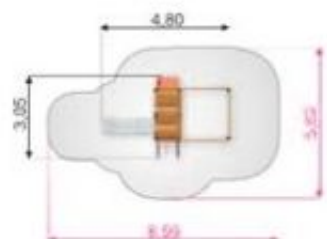

1:300

10144
KIOSK

-  3+
-  2,13 m
-  2,05 m
- W2W
METAL
-  6,5 h

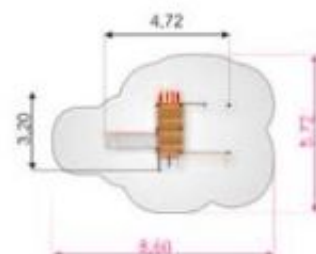

1:300

10148
CLIMBING KIOSK



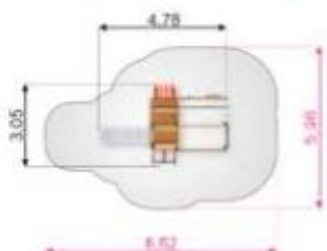

-  3+
-  2,13 m
-  2,05 m
- W2W
METAL
-  8 h



1:300



10108
GROCER'S

-  3+
-  2,13 m
-  2,05 m
- W2W
METAL
-  5,5 h

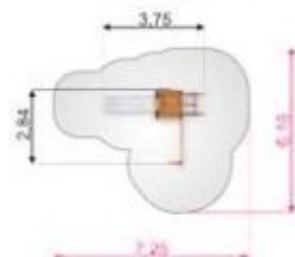

1:300

10332
ZEBRA

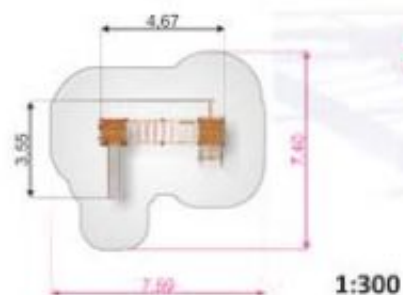

- 3+
- 2,16 m
- 2,05 m
- W2W
METAL
- 8,5 h



10101
LOGO TOWER WITH FIREPOLE

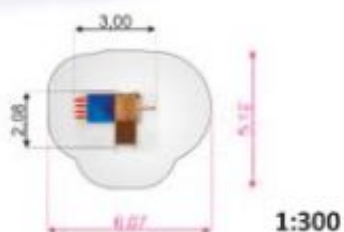

- 3+
- 3,51 m
- 2,35 m
- W2W
METAL
- 3 h



10105
LOGO TOWER WITH CLIMBING NET

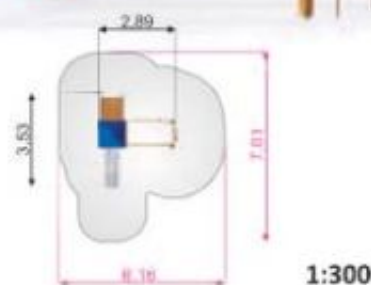

- 3+
- 2,93 m
- 1,75 m
- W2W
METAL
- 5 h



10100
LOGO TOWER

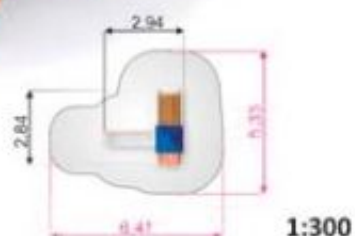

- 3+
- 3,20 m
- 1,20 m
- W2W
METAL
- 4 h



10331

PANTHER



3+



2,16 m



2,02 m



8,5 h

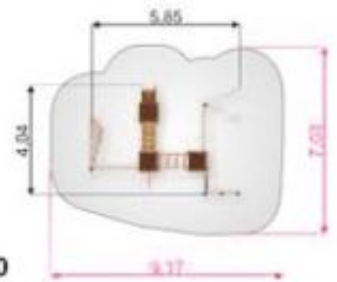

1:300

10612

CLIMBING BOX



3+



2,15 m



2,05 m



2 h

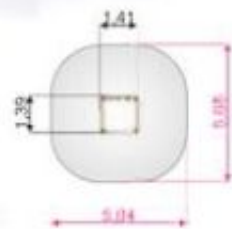

1:300



10610

CHIMPANZEE



3+



2,16 m



2,05 m



7,5 h

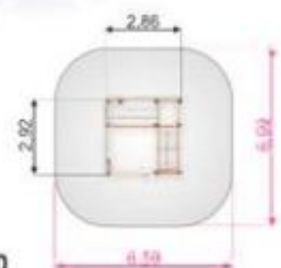

1:300

10620
ACTIVITY CENTER

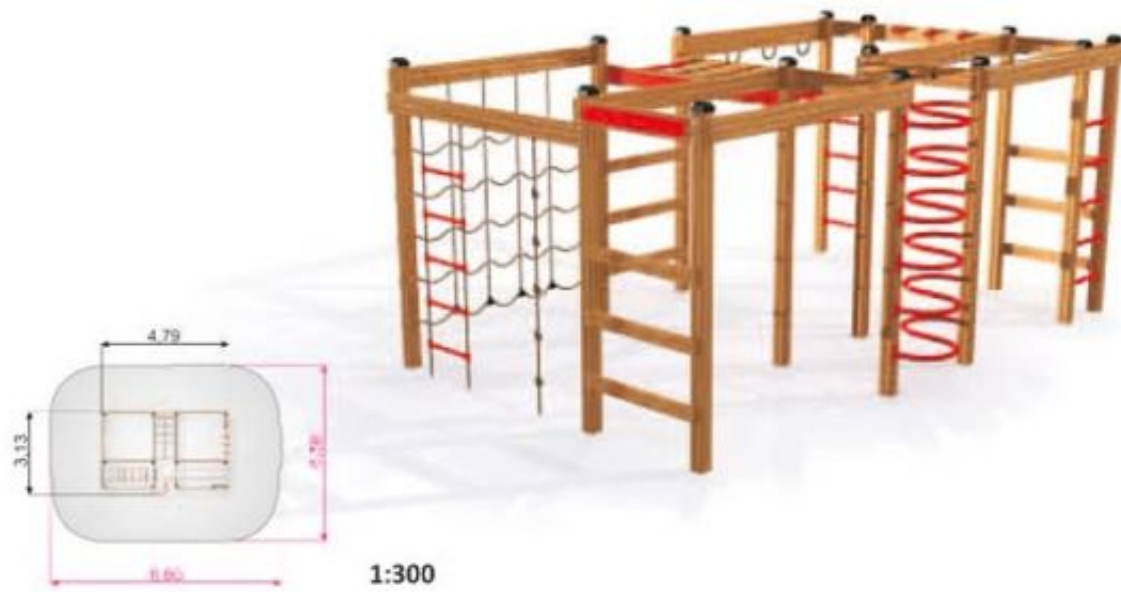

- 3+ 
- 2,16 m 
- 2,05 m 
- W2W
METAL
- 8,5 h 

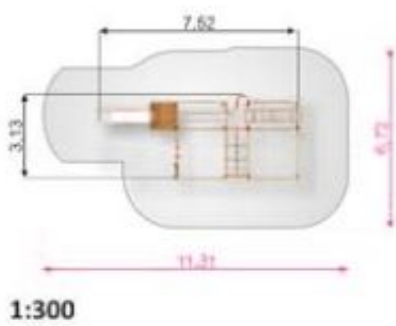

10621
ACTIVITY CENTER WITH SLIDE

- 3+ 
- 2,16 m 
- 2,05 m 
- W2W
METAL
- 10 h 



10642

POISON GROUND



3+



1,26 m



0,87 m



W2W
METAL



21 h

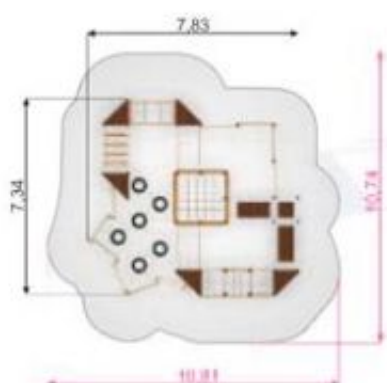

1:300



10643

COURSE



3+



1,23 m



0,87 m



W2W
METAL



12 h

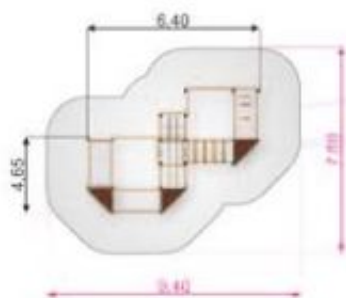

1:300



10663

TRAPEZOIDAL



10662

V-SHAPE NET

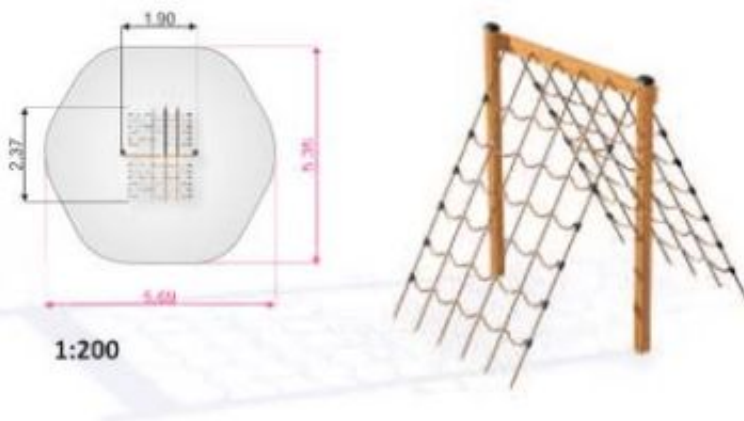

10668

HONEYCOMB



10665

HORIZONTAL LADDER

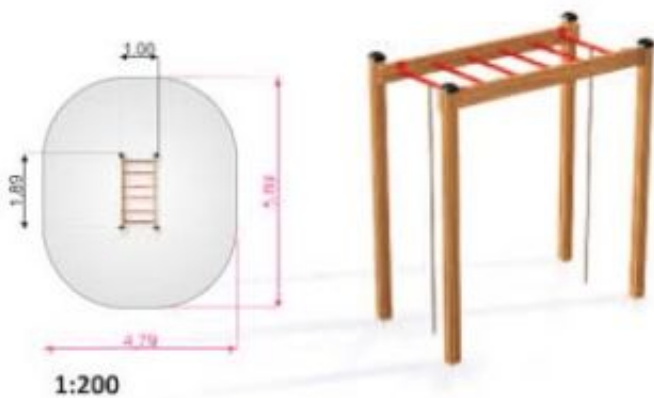

10664

HORIZONTAL LADDER II



10667 JUMPING PEGS

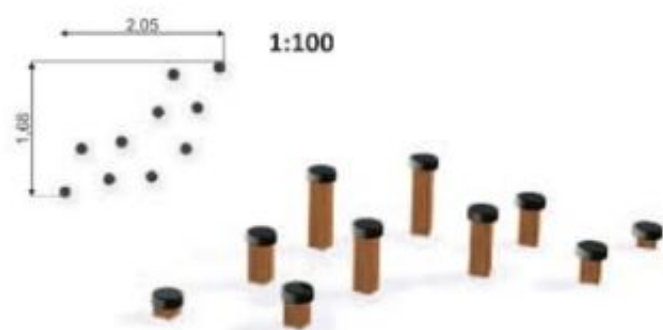

10671 VERTICAL LADDER

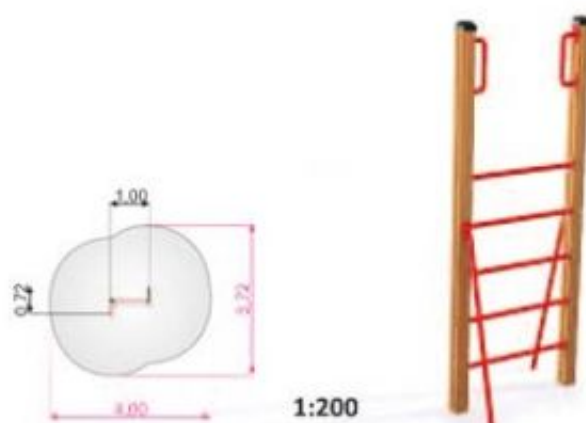

10660 BALANCE

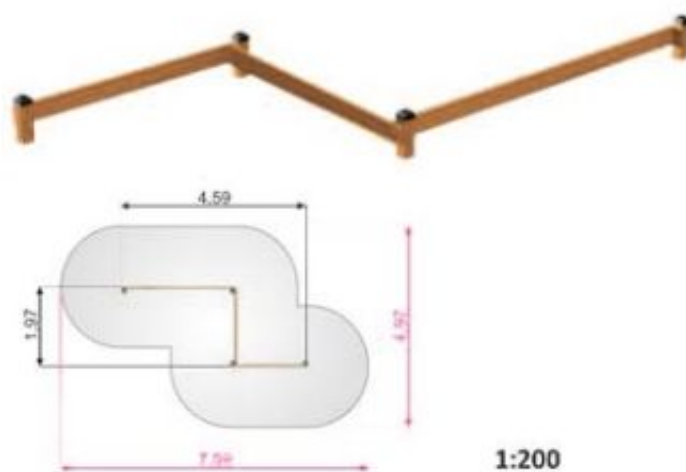

10646 TUNNEL

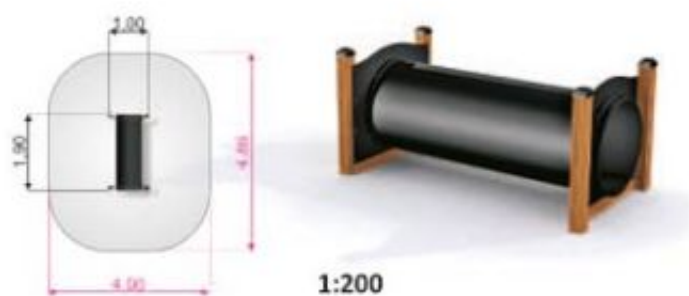

10666 CHAIN BRIDGE



10899

SOMERSAULT SINGLE

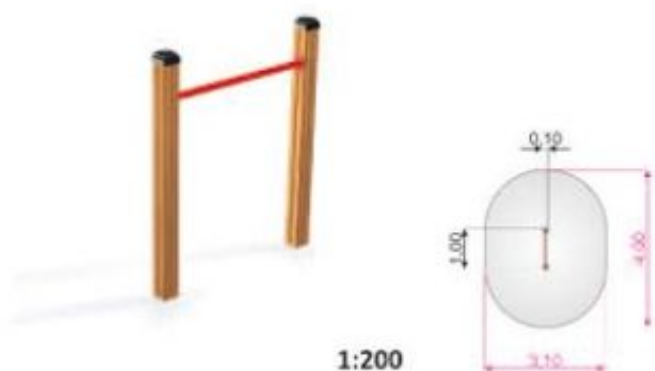

10900

SOMERSAULT DOUBLE

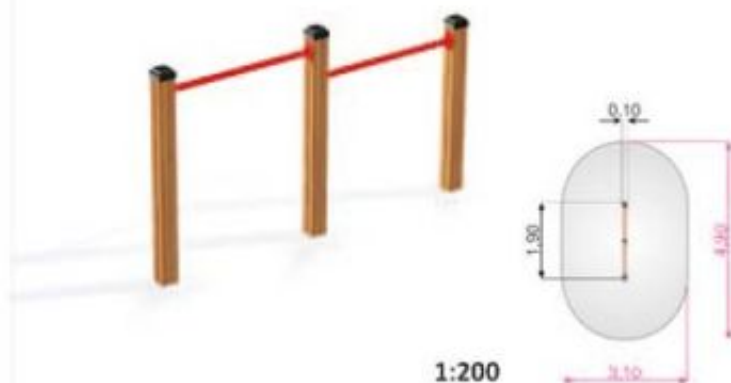

10901

SOMERSAULT TRIPLE

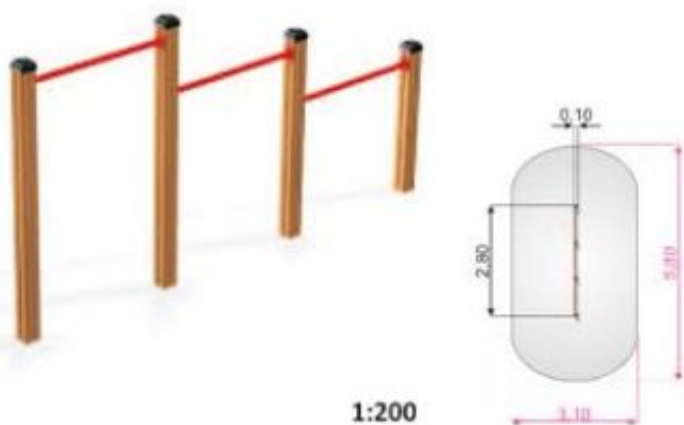

PIONEER TRIM TRAIL COMBINATION

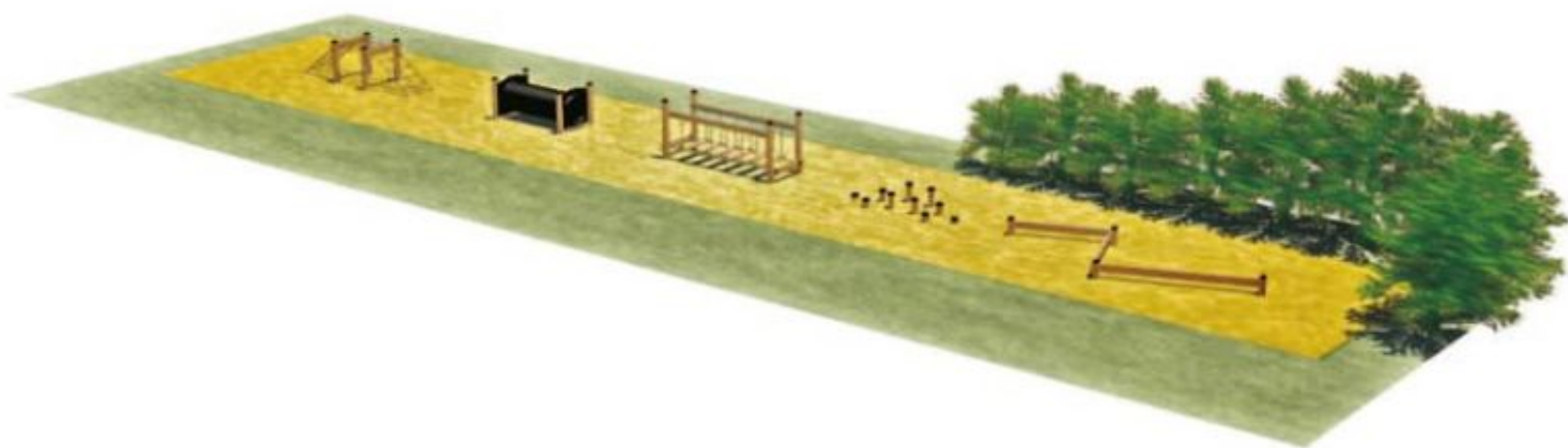

10530

SEAROBBER CASTLE

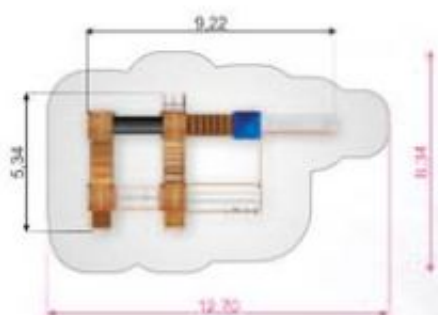

1:300



10320

MOTOR FUNCTION CENTER

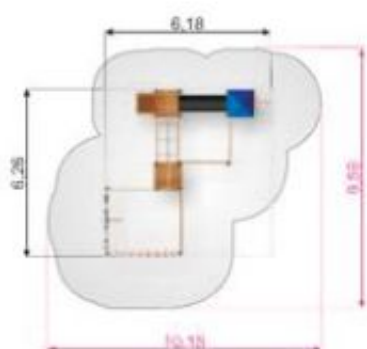

1:300



10420

SPHINX

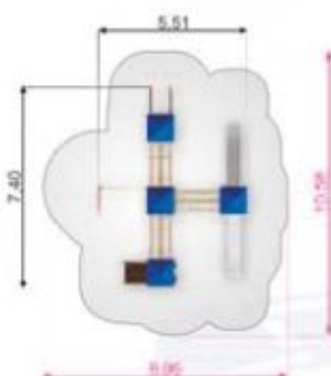

1:300





10590
SPACE STATION

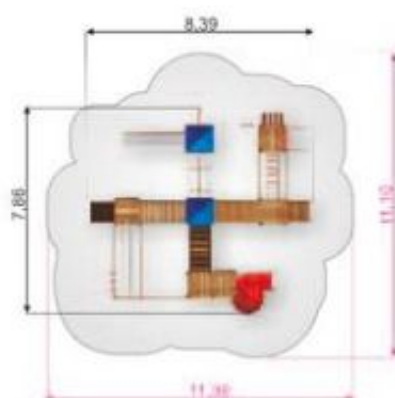

1:300



10540
KING-KONG

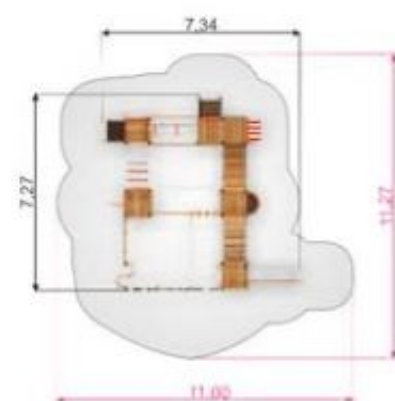

1:300

10550
TRITOWERS

-  3+
-  3,80 m
-  2,65 m
- W2W
METAL
-  21 h

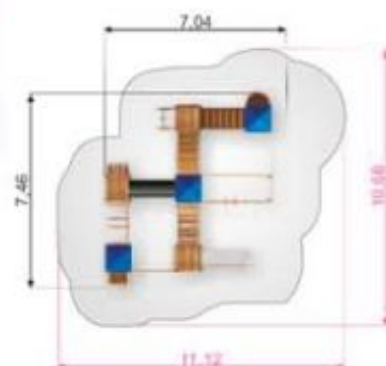

1:300

10595
GIGANTIC

-  3+
-  3,80 m
-  3,00 m
- W2W
METAL
-  86 h

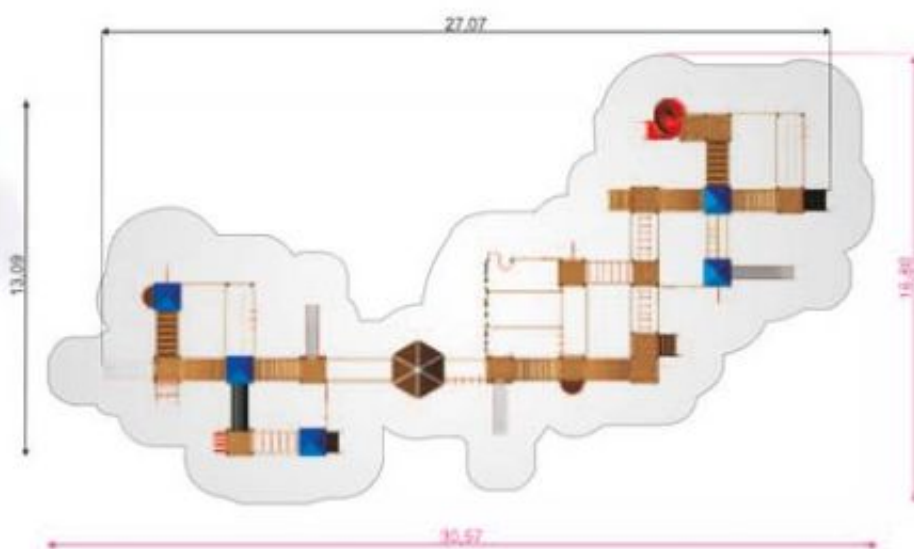

1:300



11426
BOUNTY

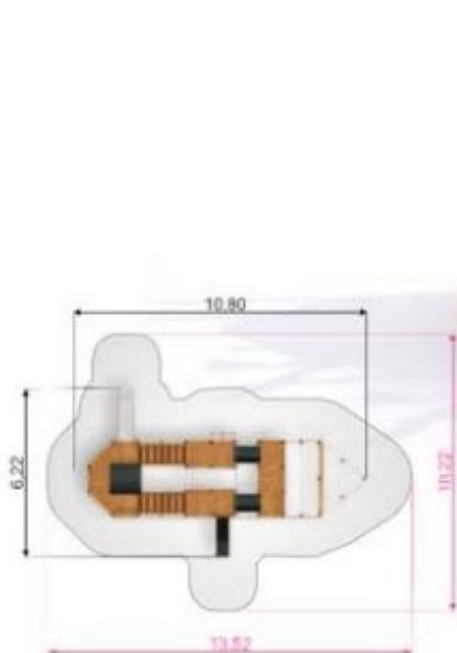

- 3+ 
- 4,26 m 
- 1,75 m 
- W2W 
- 32 h 

1:300

11428
MAJESTIC



- 3+ 
- 4,26 m 
- 2,10 m 
- W2W 
- 56 h 

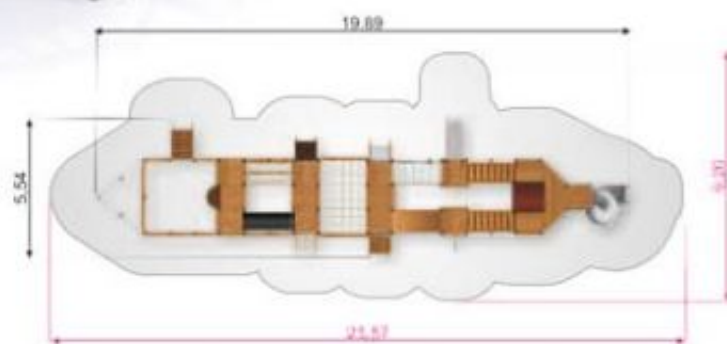

1:300



10290
TINTAGEL

			W2W METAL	
3+	4,73 m	1,20 m		8,5 h



10435
CAMELOT

			W2W METAL	
3+	4,73 m	2,05 m		17 h

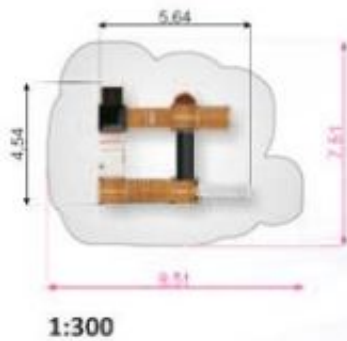

10535
WINDSOR

			W2W METAL	
3+	5,35 m	2,05 m		38 h

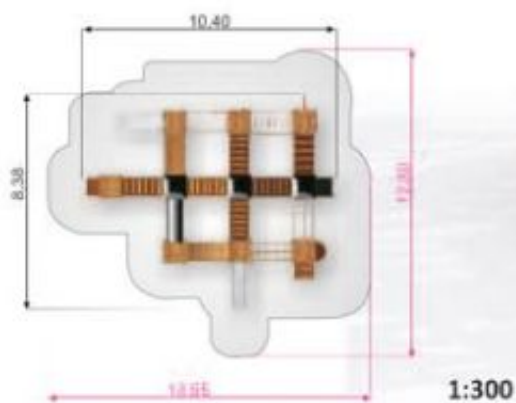

11536
APOLLO



1:300

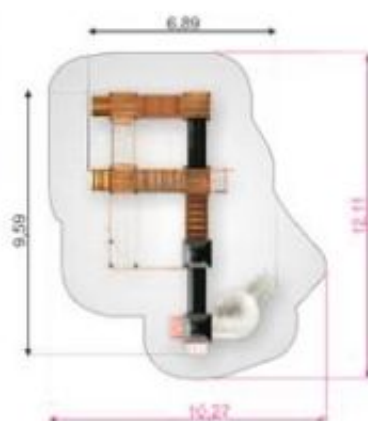

3+



3,50 m



2,36 m



W2W
METAL

21 h



10560
CITADEL



1:300

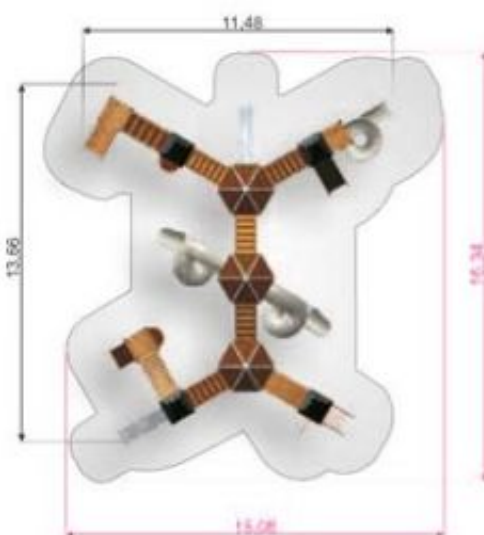

3+



5,06 m



2,10 m



W2W
METAL

60 h

