

## Product Information

### Materials testing machine with hydraulic drive Z1200H



Figure: Zwick Z1200H with hydraulic grips

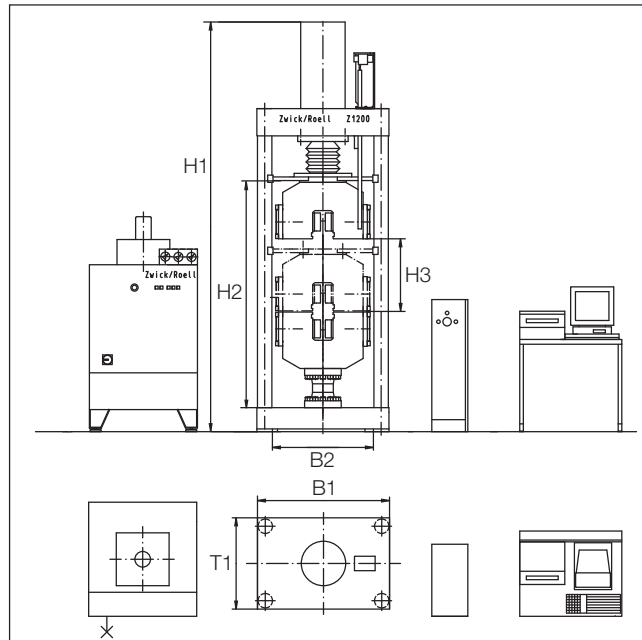

Figure: Drawing of Zwick Z1200H with hydraulic grips

#### Key benefits

- These hydraulic materials testing machines have a single, central hydraulic drive.
- Optionally available with an adjustable top crosshead, allowing the test area to be adjusted to customers' requirements.
- High-resolution, channel-synchronized measurement technology provides extremely precise, accurate determination of material characteristic values. No range-switching is necessary as load signal resolution is available over the whole range.
- Wide measuring range allows even small test loads to be determined accurately without re-tooling.

#### Further advantages and features

- Extremely stiff, robust load frame.
- Standard tests using Zwick *testXpert*<sup>®</sup> software require only single-button operation.
- Modular design throughout the system allows the entire Zwick accessory range to be used, including a wide variety of extensometers, specimen grips and other test tools.
- Should new test requirements arise, additional test tools (e.g. calibration blocks) can very easily be installed by means of a T-slot or screw system.
- Can be tailored to customers' specific requirements (e.g. test devices, specimen grips, test speed ranges, testing software).

## Product Information

### Materials testing machine with hydraulic drive Z1200H

Model	Z1200H	Z1200H
Fmax [kN]	1200	1200
Top crosshead	fixed	adjustable
Number of lead columns	4	4
Stiffness of the load frame at Fmax (without specimen grips and load cell) approx. [kN/mm]	1200	1200
Dimensions of load frame		
H1 – Height [mm]	3411	max. 3769
B1 – Width [mm]	1100	1220
T1 – Depth [mm]	760	920
Dimensions of test area		
H2– Height [mm]	1876	max. 2184
B2 – Width [mm]	850	850
H3 – Test stroke max. [mm]	600	600
Test speed max. [mm/min]	200	200
Weight		
without tools / specimen grips (with electronics) [kg]	4050	4700
with specimen grips [kg]	5350	6000
Specific floor loading [kg/cm <sup>2</sup> ]	1.6	1.8
Resolution of crosshead travel [µm]	0.16	0.16
Position accuracy [mm]	± 0.01	± 0.01
<b>Item no.</b>	<b>• 358424</b>	<b>• 358425</b>
	(BPC-F1200HN.F11)	(BPC-F1200HN.M11)

Environmental conditions		
Operating temperature [°C]	+10 ... +35	
Storage temperature [°C]	-25 ... +55	
Humidity range (not condensing) [%]	≤ 90	
Electrical connection		
Mains voltage 3 Ph/N/PE 1 2 [V]	400	
Mains frequency [Hz]	50	
Drive power [kVA]	15	
Fuse [A]	32	
Noise level in 1m distance [dB(A)]	67	
Color coating of rack	RAL7011 (iron gray), RAL7038 (agate gray)	

<sup>1</sup> Three phase AC motor (L1, L2, L3), neutral wire N, protective earth PE

<sup>2</sup> < ± 10 % related to the mains voltage