

Product Information

Servo-hydraulic load frames - HC Series

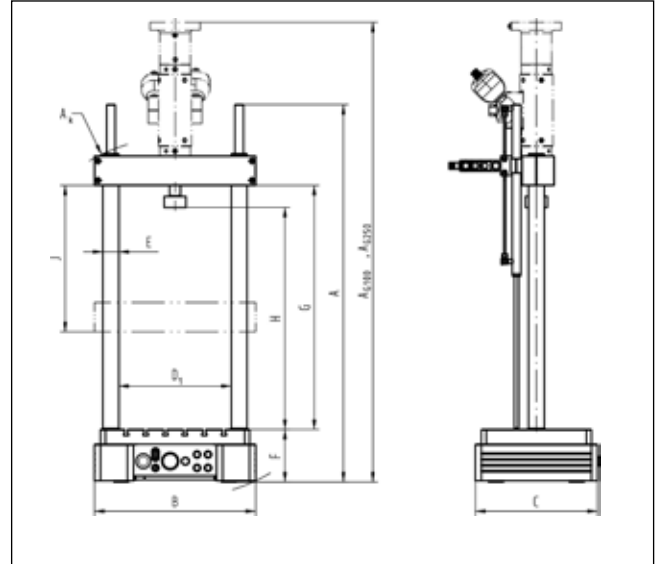

HC load frame



Drawing HC load frame

Application

The HC frame is a table-top unit designed for forces up to 25 kN. The testing actuator mounted in the upper crosshead enables the testing machine to be used both for standard fatigue tests and for flexure and component tests. The integrated T-slotted platform is hard-chromed, allowing tests involving corrosive media such as saline solutions, commonly used in biomedicine, to be performed.

Description of operation

The compact 2-column load frame is designed for materials and component testing under dynamic alternating loads in a closed force-flow. The frame is mounted on anti-vibration leveling units. For normal operation a sturdy table or workbench is a suitable support; where tests or environmental conditions are of a critical nature and high test frequencies are involved it is advisable to mount the load frame on the optional concrete base. A particularly space-saving arrangement is possible when the HC is used in combination with the 12-liter/minute low-noise power-pack, the noise-insulated power-pack serving as the base.

The load cell can be attached to the table top or the piston rod, depending on the type of test. If standard test grips are used it is advisable to mount the load cell on the fixed lower crosshead.

The frame possesses high axial and lateral stiffness, enabling lateral forces which can occur in compression and flexure tests to be absorbed without difficulty. The frame is also suitable for combined flexure or tension plus torsion loadings.

The frames feature extremely high-precision alignment. After installation of the testing actuator and load cell the alignment accuracy is +0.1 mm per meter; for distances less than 350 mm the offset is a constant 0.05 mm. Plane parallelism is equal to or better than 0.03 mm per 100 mm. All fixtures are mounted via a flange with centering spigot.

Features

- 2-column frame for dynamic tests up to 25 kN
- testing actuator installed in the upper crosshead
- suitable for axial actuator with 10 kN and 25 kN
- suitable for combined tensile/compression-torsion actuator with a maximum torque of 250 Nm
- hard-chromed T-slotted plate and columns for tests involving corrosive media
- wide range of accessories: temperature chamber, compression platens, specimen grips, flexure test kit etc.
- optional hydraulic adjustment for easy positioning of upper crosshead
- safety casing in compliance with CE Machinery Directive, depending on application

Product Information

Servo-hydraulic load frames - HC Series

Technical data

Test area height		Standard	Extended by 250 mm	Extended by 500 mm
Dynamic nominal force	[kN]	25	25	25
A – max. height of test frame	[mm]	1550	1800	2050
A _{G100} – max. height of test frame with 100 mm-stroke testing actuator	[mm]	1890	2140	2390
A _{G250} – max. height of test frame with 250 mm-stroke testing actuator	[mm]	2190	2440	2690
AK – tilted height for erection	[mm]	1480	1710	1950
B – max. width of test frame	[mm]	660	660	660
C – max. depth of test frame	[mm]	500	500	500
D1 – column spacing	[mm]	460	460	460
E – column diameter	[mm]	65	65	65
F – height top edge lower crosshead	[mm]	215	215	215
G – max. test area height ¹	[mm]	1000	1250	1500
H – max. working test area height ²	[mm]	910	1160	1410
J – crosshead adjustment travel ³	[mm]	600	600	600
Weight ⁴	[kg]	395	410	425
Frame stiffness at 1000 mm crosshead separation	[kN/mm]	300	300	300
Clamping/adjustment: manual/manual		• 935276 <small>(BPS-FC0025.00.05)</small>	• 935450 <small>(BPS-FC0025.00.06)</small>	• 935720 <small>(BPS-FC0025.00.0)</small>
Clamping/adjustment: manual/hydraulic		• 935275 <small>(BPS-FC0025.10.05)</small>	• 936110 <small>(BPS-FC0025.10.06)</small>	• 936259 <small>(BPS-FC0025.10.07)</small>

¹ Distance between lower and upper crossheads

² Distance between piston flange and lower crosshead with retracted piston

³ Only for frames with hydraulic adjustment

⁴ Weight less actuator, load cell and any fixtures

Accessories

Description	Item No.
Piston rod extension for LH 10/25 kN actuator	• 003953 <small>(BPS-LH0025.90.03)</small>
Piston rod anti-rotation lock for HC frames	• 644085 <small>(BPS-FC0025.80.04)</small>
Base for HC load frames, concrete version	• 935284 <small>(BPS-FC0025.80.02)</small>
<ul style="list-style-type: none"> • Dimensions (H x W x D): 704 x 800 x 700 mm • Weight: 830 kg 	

Safety device

Frame height	Standard	Extended by 250 mm	Extended by 500 mm
Safety device, 4-sided	• 936251 <small>(BPS-FC0025.90.02)</small>	• 048741 <small>(BPS-FC0025.90.10)</small>	• 936263 <small>(BPS-FC0025.90.03)</small>
Safety device, 3-sided in conjunction with a temperature chamber	-	• 016514 <small>(BPS-FC0025.90.05)</small>	• 020984 <small>(BPS-FC0025.90.06)</small>

Aluminium profile construction with Makrolon panels, front safety door electrically monitored and interlocked.