

**UNIMAX 2010  
PROMAX 2020  
POLYMAX 2040**



**Betriebsanleitung  
Instruction Manual  
Mode d'Emploi  
Instrucciones de  
Empleo  
Istruzioni per l'uso**

**D** DEUTSCH Seite 3 - 16

**E** ENGLISH page 17 - 30

**F** FRANCAISE page 31 - 44

**ES** ESPAGNOL página 45 - 58

**I** ITALIANO Pagina 59 - 72

Thank you for purchasing a Heidolph Instruments product. This item has been designed, made and inspected in compliance with DIN EN ISO 61010 for long-term and flawless operation.

**SUMMARY**

- Summary..... 17
- Standard hardware & options..... 18
- General..... 19
- Safety information..... 19
- Set-up..... 20
  - 1. machine set-up ..... 20
  - 2. electric hook-up ..... 20
  - 3. load vessels on vibrator table ..... 20
    - 3.1. universal mount with base frame and clamping rollers ..... 20
    - 3.2. rack with clips ..... 21
    - 3.3. rack for separating funnel..... 22
    - 3.4. multi-level set-up..... 23
- Operation and controls..... 24
- Cleaning & servicing..... 25
- Disassembly & storage..... 26
- Disposal..... 26
- Troubleshooting..... 26
- Specifications..... 27
  - UNIMAX 2010..... 27
  - PROMAX 2020..... 28
  - POLYMAX 2040..... 28
- Warranty, liability & copyright..... 29
- FAQ / repair work..... 29
- CE-declaration of conformity..... 30



**Important information**



**Advice about power cord / mains supply**



**Caution: mandatory action**



**Caution: fire- and explosion hazard**



**Advice about maintenance / repair**





## STANDARD HARDWARE & OPTIONS

	product	quantity	P/N 230/240V 50/60Hz	P/N 115V 50/60Hz
--	---------	----------	-------------------------	---------------------



### Shakers / Mixers

	<b>UNIMAX 2010</b>	1	542-10020-00	542-10020-01
or	<b>PROMAX 2020</b>	1	542-20020-00	542-20020-01
or	<b>POLYMAX 2040</b> (5° tilt)	1	542-40005-00	542-40005-01
or	<b>POLYMAX 2040</b> (10° tilt)	1	542-40010-00	542-40010-01
	Instruction Manual	1	01-005-002-31	01-005-002-31
	Power cord	1	14-007-003-81	14-007-003-89



### Accessories

	product	P/N
	base frame	549-50000-00
	clamping roller	549-58000-00
	universal tray	549-59000-00
	clamp for 25 ml Erlenmeyer flask (36 ea. per tray)	549-51000-00
	clamp for 50 ml Erlenmeyer flask (36 ea. per tray)	549-52000-00
	clamp for 100 ml Erlenmeyer flask (23 ea. per tray)	549-53000-00
	clamp for 250 ml Erlenmeyer flask (12 ea. per tray)	549-54000-00
	clamp for 500 ml Erlenmeyer flask (9 ea. per tray)	549-55000-00
	clamp for 1000 ml Erlenmeyer flask (5 ea. per tray)	549-56000-00
	holder for separating funnel 250 ml, 500 ml, 1000 ml	549-57000-00
	holder for separating funnel 2000 ml	549-61000-00
	hardware for multi-level set-up	549-60000-00

## GENERAL

-  Unpack your item carefully. Inspect for damage and report such damage or missing parts to your supplier right away.
-  Read your Instruction Manual carefully. Take time to save time while working with your product. Make sure that every user has read and understood the Instruction Manual.
-  Please store the Instruction Manual in a place easily accessible to every user.

### IF ALL ELSE FAILS, READ THESE INSTRUCTIONS !

-  A so-called EURO-plug (DIN 49441 CEE 7/VII 10/ 16 A 250 V) is standard on all of the products.  
For the Continental US they feature a US-standard plug (NEMA Pub.No.WDI.1961 ASA C 73.1 . 1961 page 8 15A 125V).
-  For using the item in a country with deviating outlet / plug systems, we recommend to use approved adapters or to have an electrician replace the standard plug with one mating your local system.
-  As shipped, the item features a protective ground wire. When replacing the original plug, make sure to reconnect this protective ground wire in the new plug !

## SAFETY INFORMATION

-  **Please comply with all safety and accident-prevention regulations as in force for laboratory work!**
-  **Use extra care when working with flammable substances; refer to safety data sheets.**
-  **Use extra care when working in the vicinity of flammable and explosive substances. Motors are of non-sparking type, the item itself however is not explosion-proof.**
-  **When connecting your item with your local power supply, please make sure your item is wired for your local voltage; refer to data plate on the item.**
-  **Please connect your unit with a protective-ground outlet only.**
-  **Repair work is limited to technicians approved by Heidolph Instruments.**
-  **Your item needs a solid stand.**
-  **Lab bench needs to be of rigid design, and features an anti-skid surface coat.**



**Before starting the item, make sure all vessels are attached safely (must not move while shaking).**

## SET-UP

### 1. Set-up

Please locate the shaker on a rigid, horizontal surface. For safety reasons, keep the area around the machine clear of other items.

Be aware of orbital movement of the shaker plate and vessel set-up protruding over the standard table surface.

### 2. Electric hook-up

Use the power cord from your hardware bag and connect it with the plug connector in the item's rear panel.

The item features two-pole circuit breakers located in the item's plug connector for ease of access. For circuit breaker details refer to data plate.

### 3. Secure vessels on shaker plate

To secure vessels on shaker plate, use optional adapters. Adapters for Erlenmeyer flasks, separating funnels and a universal adapter with clamping rollers are available. For more details refer to standard equipment and options.

In some cases using low shaking speed, vessels like Petri dishes just may be put on the anti-skid rubber plate that comes with the item as a standard option.



Before starting shaking, make sure all vessels are secured in place properly.

#### 3.1. Universal mount with base frame and clamping rollers.

Base frame and clamping rollers allow to safely attach whatever sort of vessels and racks on the shaker plate.

**base frame** (P/N 549-50000-00)

**clamping roller** (P/N 549-58000-00) 2 ea. minimum

The base frame goes on the shaker plate as described below:

Remove round rubber caps located in the four corners.

Thread 4 ea. bolts (1) in the respective holes and pull tight with box-end spanner (2) from hardware bag. Slip holding bar (3) over bolts (1) and secure with wingbolts (5).

Slip clamping rollers over holding bars (3), push against the vessel to be clamped, and secure with wingbolts (5).

**clamping roller**  
(P/N 549-58000-00)

**base frame**  
(P/N 549-50000-00)

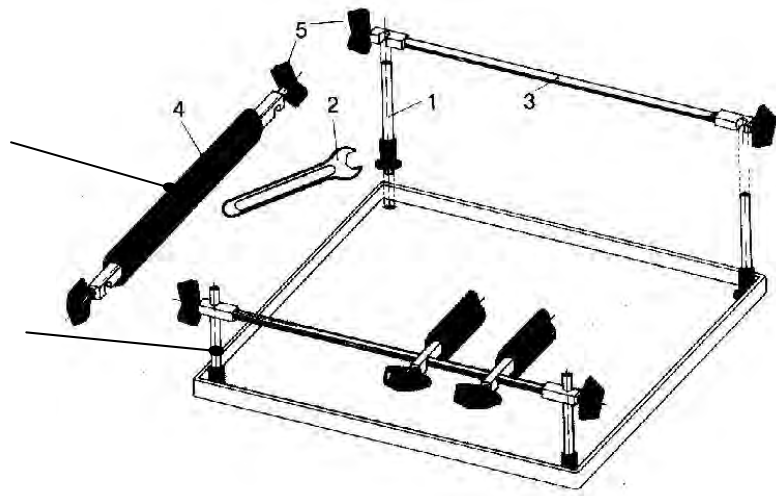

Attaching one more row of vessels requires installation of extra clamping rollers.



Before starting shaking, make sure all vessels and clamping rollers are safely locked in place and all screws of the universal mount have been pulled tight as specified.

### 3.2. Rack and holding clamps for Erlenmeyer flasks

This rack with appropriate clamps allows to safely hold Erlenmeyer flasks of even different sizes on the shaker plate.

Components: rack, P/N 549.59000.00 plus clamps (quantity as required):

- for 25 ml Erlenmeyer flask max. 36 ea. per rack, P/N 549.51000.00
- for 50 ml Erlenmeyer flask max. 36 ea. per rack, P/N 549.52000.00
- for 100 ml Erlenmeyer flask max. 23 ea. per rack, P/N 549.53000.00
- for 250 ml Erlenmeyer flask max. 12 ea. per rack, P/N 549.54000.00
- for 500 ml Erlenmeyer flask max. 9 ea. per rack, P/N 549.55000.00
- for 1000 ml Erlenmeyer flask max. 5 ea. per rack, P/N 549.56000.00

Distribution of holes in the rack permits whatever combination of clamps.

The only restriction is to arrange clamps in a manner avoiding direct contact between each other; moreover, flasks should not protrude over the edge of the shaker plate.

How to install clamps:

- Remove nuts (3) and washers (2) from clamp bolts (1).
- Plug clamp (1) in rack hole and secure with washer (2) and nuts (3); tighten with box-end spanner (4) from hardware bag.
- 25 to 100 ml clamps feature a threaded bolt, whereas 250 - 1000 ml clamps use four each bolts.

Locate rack with clamps installed on shaker plate.



Make sure, crimped edge (5) is plugged over shaker plate (6), thus positively locking both parts with each other.

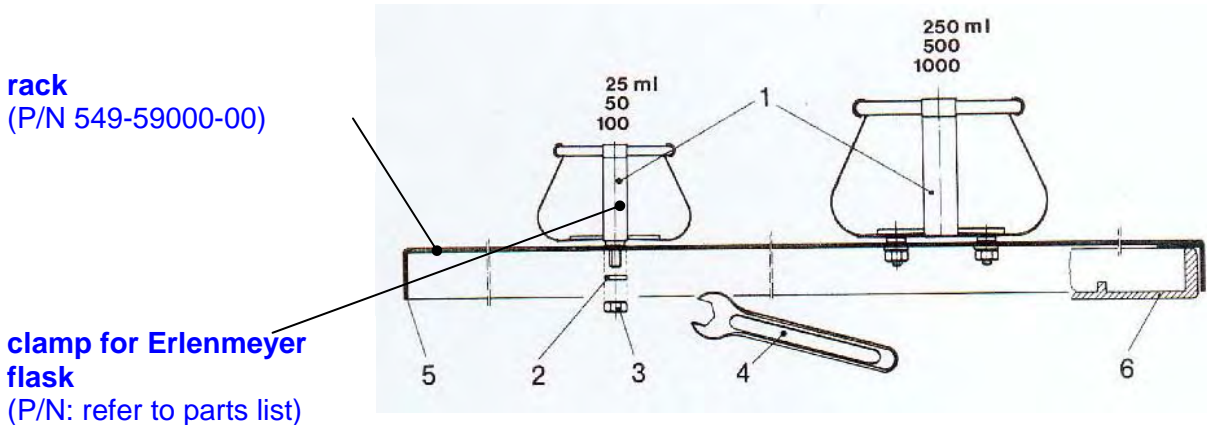

### Install Erlenmeyer flasks in holders:

Lightly tilt Erlenmeyer flasks to fit them under the clamp.



Before starting shaking, double check Erlenmeyer flasks for proper seat in their clamps and all screws have been pulled tight.

### 3.3. Rack and holder for separating funnels

Rack and separating funnel holder safely hold size 250 ml, 500 ml, 1000 ml or 2000 ml separating funnels on the shaker plate.

Components: rack, P/N 549.59000.00 and separating funnel holders (as required):

- holder for size 1 (250, 500 or 1000 ml) separating funnels, P/N 549.57000.00
- holder for size 2 (2000 ml) separating funnels, P/N 549.61000.00

One rack accepts the following number of separating funnel holders: 4 ea. 250 ml, 3 ea. 500 ml, 3 ea. 1000 ml or 2 ea. 2000 ml; a mix of various sizes may be used either.

#### Install holders:

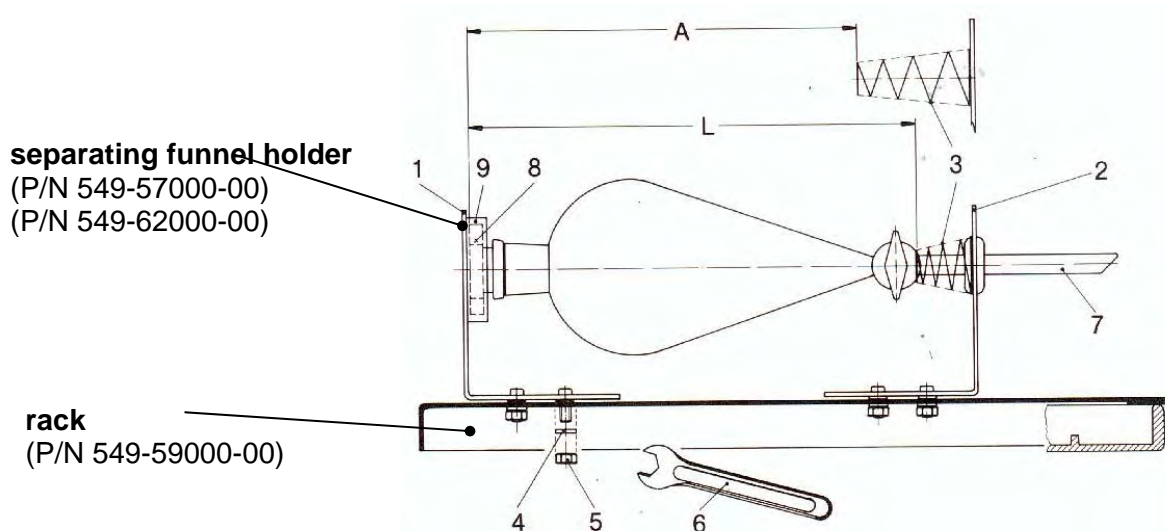

- Remove nuts (5) and washers (4) from part (1) & (2) bolts.
- Plug part (1) and part (2) into the rack's holes, so that dimension "A" is about 25 mm less than length "L" of the separating funnel; as to guarantee proper clamping of the separating

funnel and its closing plug by means of compression spring (3). Dimension "A" once set will be good for one and the same size of separating funnel only. Whenever using a different model of separating funnel, you need to check dimension "A" and readjust accordingly.

- Install washer (4) and nuts (5) on bolts of parts (1) and (2); pull tight with box-end spanner (6) from your hardware bag.

Locate rack with holders on shaker plate.

Make sure, crimped edge (10) is plugged over the shaker plate (11), so positively locking both parts with each other.

### Install separating funnel:

Install separating funnel with its outlet pipe (7) first through compression spring (3); press item against compression spring (3) until closing plug (8) kocks with retainer ring (9).



Before starting shaking, make sure that the outlet pipes (7) of your separating funnels are clear of other items on your lab bench. Maintain sufficient space between separating funnels to avoid a collision situation.

### 3.4. Hardware for multi-level set-up

This hardware allows installation of a second or third rack plate for Erlenmeyer flasks on the shaker plate.

Using 25 ml Erlenmeyer flasks, a total of 3 racks may be set-up the same time, whereas 50 ml to 250 ml Erlenmeyer flasks may be arranged on 2 only racks.

Components: installation hardware for multi-level set-up, P/N 549.60000.00; extra racks with clamps for Erlenmeyer flasks, as described under para. 3.2.

#### Set-up:

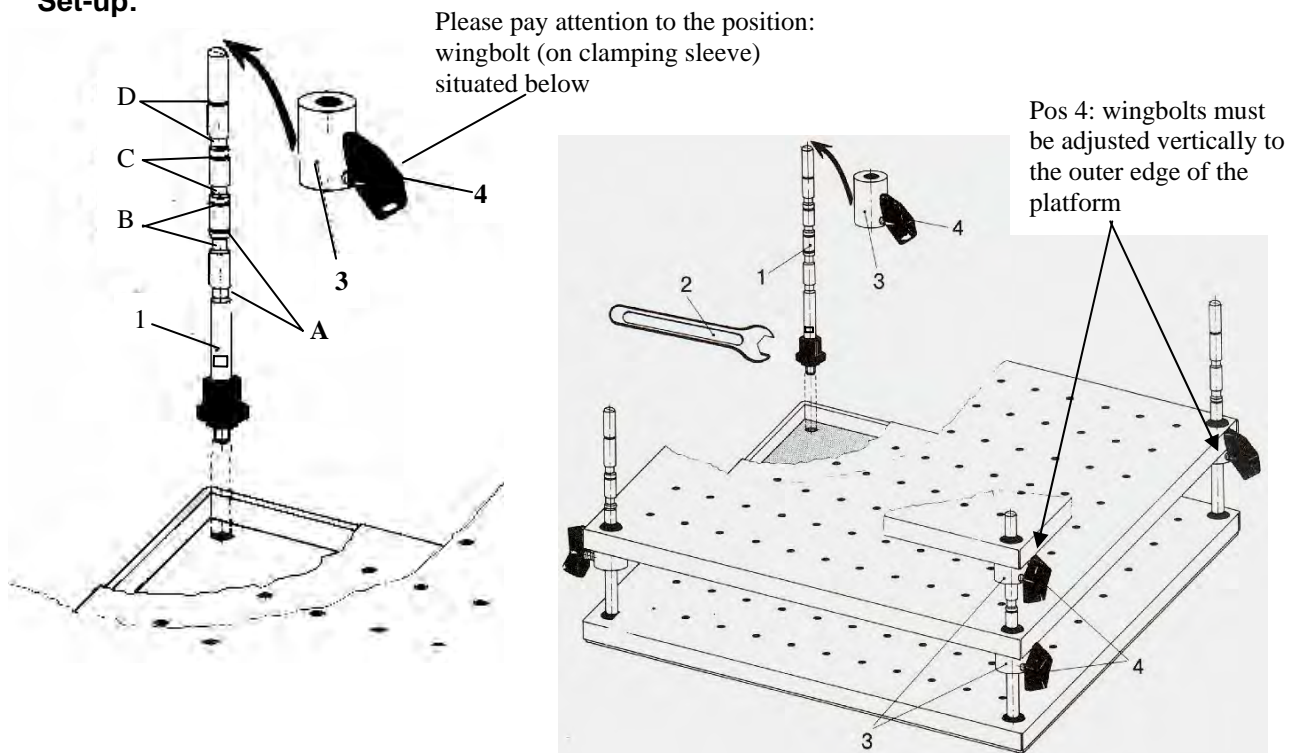

# E

Install 4 ea. columns (1) and pull tight with box-end spanner (6) from your hardware bag. Locate first rack panel over columns. Slip 4 ea. clamping sleeves (3) over column (1) and secure with wingbolt (4) (wingbolts must be adjusted vertically to the outer edge of the platform).

Column (1) features vor marks for clamping sleeve (3) offest A, B, C and 3D.



3 ea. racks for 25 ml Erlenmeyer flask: A & D marks  
2 ea. racks for 50 ml Erlenmeyer flasks: B mark  
2 ea. racks for 100 ml Erlenmeyer flasks: C mark  
2 ea. racks for 250 ml Erlenmeyer flasks: D mark

Install second rack over column (1) and seat on clamping sleeve (3).  
Install 3rd rack (if required) by repeating above steps.



Before starting shaking, make sure all vessels are securely held by their clamping brackets and all bolts have been pulled tight.

## OPERATION AND CONTROLS

-  Before connecting power cord with mains outlet, make sure that:
  - your item is wired for your local voltage and frequency (data plate on item).
  - master switch is set to "0" and all controls are in "min." position (turn CCW completely); this way you avoid spilling fluids by too intense shaking action.
-  Carefully close your vessels and select appropriate shaking intensity (if flasks remain open) to avoid splashes and spillage.
-  We recommend starting with low shaking speed and gradually increase frequency to avoid accidental shaking at high speed.

On principle, one single flask should be arranged in the middle of the shaker plate, whereas more flasks should be distributed equally on the plate.

-  At high loads (load-bearing capacity of shaker plate) and high frequency of shaking, always make reference to load graph as applicable for your item (refer to "Specifications" section).



When handling hazardous fluids, make reference to applicable safety information.

The control panel features the following controls (from right to left):

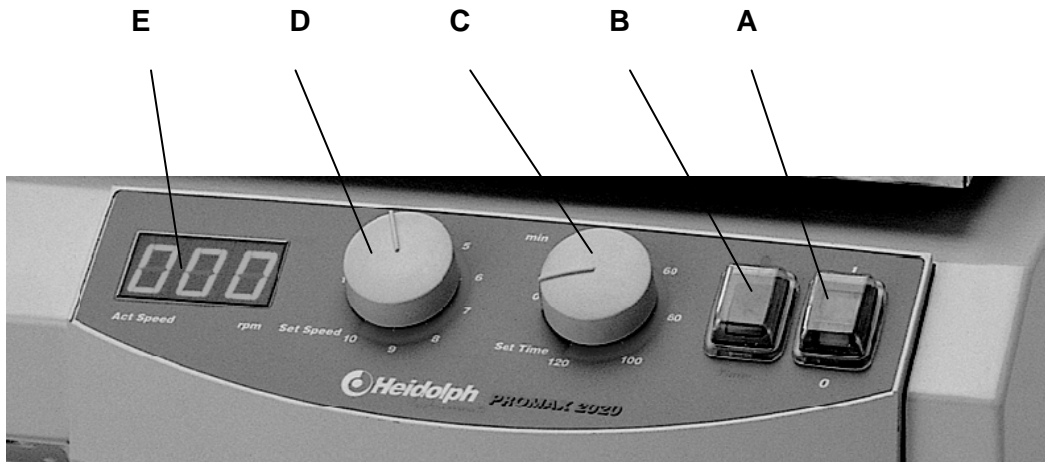

- A 2-pole master switch (toggle-type, lighted green)
- B continuous / timer-control selector
- C timer setting knob
- D speed selector knob
- E 3-digit speed display

1. Turn item ON with master switch (A).
2. Select speed with speed selector (D).
3. Select continuous / timer controlled operation with selector (B) (symbol ●) or timer control (timer). In the timer mode, shaking action can be selected between 0 and 120 minutes; the timer will continue running even in absence of power supply.
4. Actual speed appears in the 3-digit digital display.

 When using shakers inside conditioning cabinets, make reference to ambient conditions as stipulated in the "Specifications" Section).

## CLEANING & SERVICING

**Cleaning:** wipe housing clean with a damp cloth (add some sort of mild liquid soap).



### Note

To avoid damage to the surface finish, avoid using chlorine bleach, chlorine-based detergents, abrasive substances, ammonia, rags or cleaning agents containing metal particles.

The item is maintenance-free. Repair work is limited to technicians so approved or appointed by Heidolph Instruments. Please call your local Heidolph Instruments Dealer or a Heidolph Instruments Field Representative (also refer to page 29)



## DISASSEMBLY & STORAGE

### Disassembly

1. Turn item OFF and disconnect mains plug.
2. Remove all of the hardware arranged around the shaker to ease disassembly.
3. Unload all flasks from shaker, uninstall optional equipment.

### Forward & Store

1. We recommend to store the item and its components in its original box, or a similar container that guarantees adequate protection against damage in transit. Tape the box securely.
2. Store the item in a dry place.



Caution

Do not jolt or shake the item during transport.

## DISPOSAL

For disposal, please comply with your local or national regulations.  
Split by metal, plastic, etc.  
Packing material to be treated as described above (material split).

## TROUBLESHOOTING

Work on electric, electronic and cryogenic components is limited to qualified personnel.

### Master switch on shaker / mixer won't light

1. Check power cord
2. Check circuit breakers

### Item won't shake (master switch lighted)

1. Timer run-down
2. Thermal motor circuit breaker triggered by motor overload  
Remedy:  
Wait about 20 minutes, decrease load applied on shaker plate.
3. Mechanical parts broken (humming motor noise) or electronic failure (no motor noise).

**SPECIFICATIONS**

**all shakers**

space required	415 x 455 mm
weight of item	abt. 15 kg
ambient temperature	0°C to 50°C at 80% rel. humidity approved for installation in gassing and conditioning cabinets (make reference to temperature limits)
power dissipation	66 W
voltage / frequency	230/240V 50/60Hz; 115V 50/60Hz optional
protective class	IP 20
power source	condenser motor, electronic speed control

**UNIMAX 2010**

shaker frequency	20 – 400 1/min
total stroke / orbit	20 mm
motion type	rotating
load-bearing capacity	static: 10 kg; less at high shaking frequency
timer	0 – 120 minute timer / continuous operation
shaker plate	390 mm x 340 mm features anti-skid rubber coating



- When running at high shaking frequency, make reference to graph for decrease in load-bearing capacity of shaker plate.

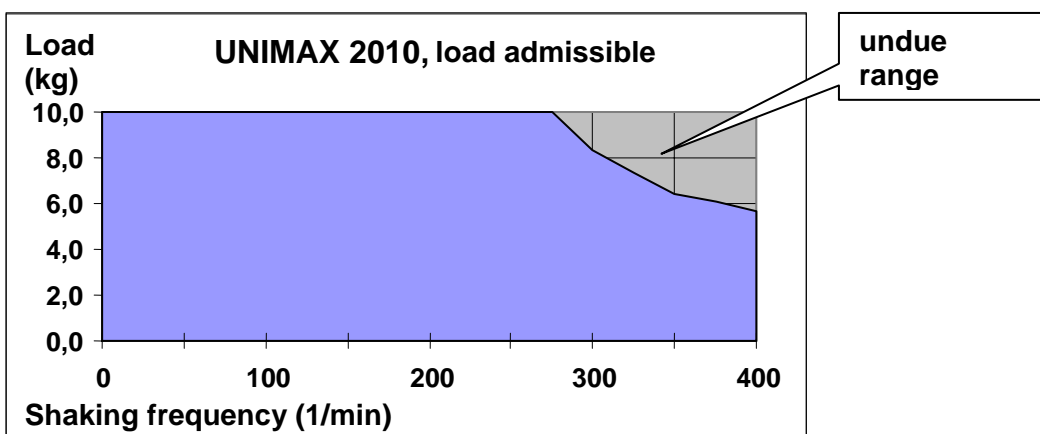



## PROMAX 2020

shaker frequency	20 – 400 1/min
total stroke / orbit	20 mm
motion type	reciprocal
load bearing capacity	static: 10 kg; less at high shaking frequency
timer	0 – 120 minute timer / continuous operation
shaker plate	390 mm x 340 mm features anti-skid rubber coating



- When running at high shaking frequency, make reference to graph for decrease in load bearing capacity of shaker plate.

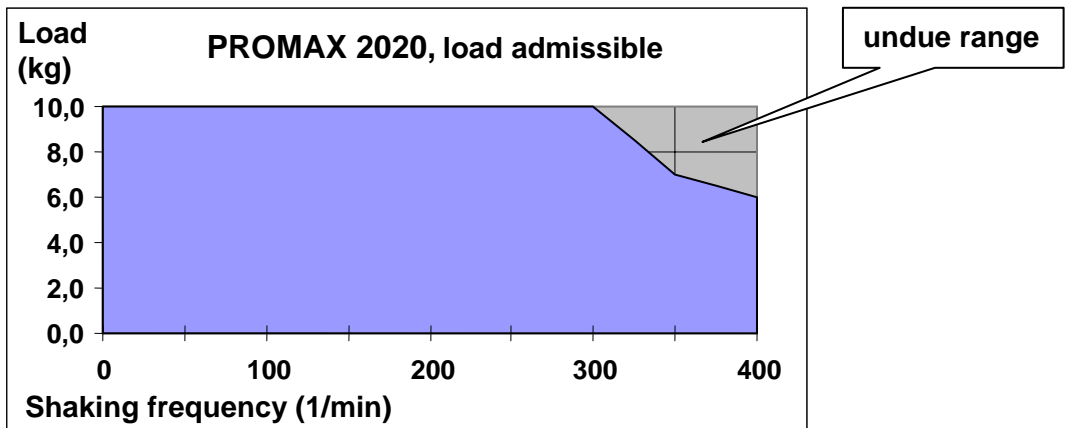

## POLYMAX 2040

shaker frequency	2,5 – 50 1/min
angle	5 / 10°
motion type	rocking
load-bearing capacity	static: 10 kg; less at high shaking frequency
timer	0 – 120 minute timer / continuous operation
shaker plate	390 mm x 340 mm features anti-skid rubber coating



- When running at high shaking frequency, make reference to graph for decrease in load bearing capacity of shaker plate.

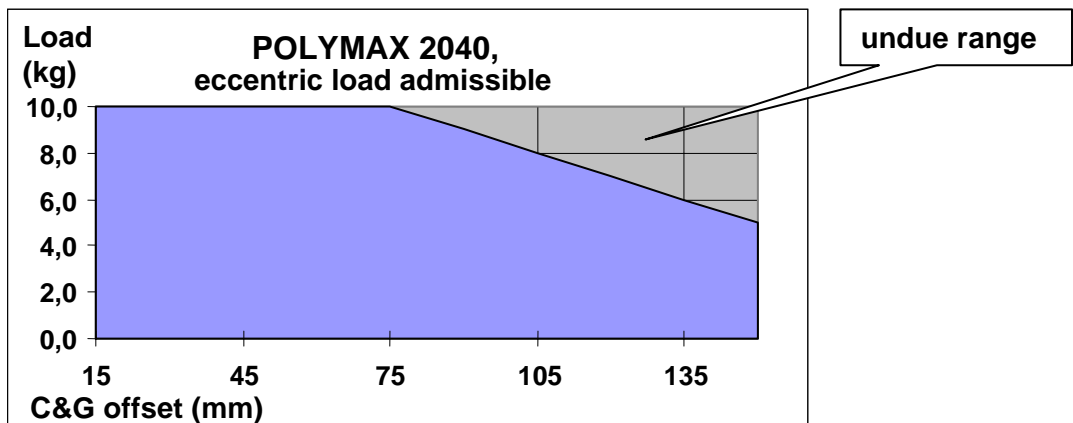

## WARRANTY, LIABILITY & COPYRIGHT

### Warranty

Heidolph Instruments guarantees that the present product shall be free of defects in material (except wear parts) and workmanship for 3 years from the date shipped off the manufacturer's warehouse.

Damage in transit is excluded from this warranty.

To obtain such warranty service, contact Heidolph Instruments (phone:++49-9122-9920-68) or your local Heidolph Instruments Dealer. If defects in material or workmanship are found, your item will be repaired or replaced at no charge.

Misuse, abuse, neglect or improper installation are not covered by this warranty.

Alterations to the present warranty need Heidolph Instruments' consent in writing.

### Exclusion Clause

Heidolph Instruments cannot be held liable for damage from improper use or misuse. Remedy for consequential damage is excluded.

### Copyright

Copyright in pictures and wording of the present Instruction Manual is held by Heidolph Instruments.

## FAQ / REPAIR WORK

If any **aspect** of installation, operation or maintenance remains unanswered in the present Manual, please contact the following address:

For repair work please call Heidolph Instruments after-sales service (phone:++49-9122-9920-72) or your local, authorized Heidolph Instruments Dealer.



### Note

You will receive approval for sending your defective item to the following address:

#### Heidolph Instruments GmbH & Co. KG

Lab Equipment Sales

Walpersdorfer Str. 12

D-91126 Schwabach / Germany

phone: ++49-9122-9920-68

Fax: ++49-9122-9920-65

E-Mail: Sales@Heidolph.de



### Note

If you are based in the United States of America, please contact Heidolph US :

#### Heidolph Instruments, LLC

Lab Equipment Sales

2615 River Rd.

Cinnaminson, NJ 08077

Phone: 856-829-6160

Fax: 856-829-7639

E-Mail: heidolph@snip.net

**Safety Information**

When shipping items for repair that may have been contaminated by hazardous substances, please:

- advise exact *substance*
- take proper *protective* action to ensure the safety of our receiving and service personnel
- *mark* the pack IAW Hazardous Materials Act

**CE-DECLARATION OF CONFORMITY**

We herewith declare that the present product complies with the following standards and harmonized documents:

**EMC-guideline (89/336/EWG):**

EN 61326: 1997 + A1:1998 + A2:2001 + A3:2003  
EN 61000-3-2: 2000  
EN 61000-3-3: 1997 + A1 2001  
EN 61326: 1997 + A1:1998 + A2:2001 + A3:2003  
EN 61000-4-2:1995 + A1:1998 + A2:2001  
EN 61000-4-3:2002 + A1:2002  
EN 61000-4-4:1995 + A1:2001 + A2001  
EN 61000-4-5:1995 + A1:2001  
EN 61000-4-6:1996 + A1:2001  
EN 61000-4-11:1994 + A1:2001

**Low-voltage guideline (73/23/EWG):**

EN 61010  
EN 61010-2-051



### Avvertenze di sicurezza

Nel caso in cui sia necessario spedire un apparecchio che deve essere riparato e che è stato a contatto con sostanze pericolose, si raccomanda di:

- Fornire *indicazioni* quanto più precise sulle *sostanze* che compongono il mezzo in questione
- *Prendere le dovute misure di sicurezza* per garantire l'incolumità del nostro personale addetto al ricevimento merce e alla manutenzione.
- *Contrassegnare* l'imballo conformemente alla normativa sulle sostanze nocive



## DICHIARAZIONE DI CONFORMITÀ CE

Dichiariamo che il presente prodotto è conforme alle seguenti norme e documenti normativi:

### Direttiva CEM (89/336/EWG):

EN 61326: 1997 + A1:1998 + A2:2001 + A3:2003  
EN 61000-3-2: 2000  
EN 61000-3-3: 1997 + A1 2001  
EN 61326: 1997 + A1:1998 + A2:2001 + A3:2003  
EN 61000-4-2:1995 + A1:1998 + A2:2001  
EN 61000-4-3:2002 + A1:2002  
EN 61000-4-4:1995 + A1:2001 + A2001  
EN 61000-4-5:1995 + A1:2001  
EN 61000-4-6:1996 + A1:2001  
EN 61000-4-11:1994 + A1:2001

### Direttiva sulla bassa tensione (73/23/EWG):

EN 61010  
EN 61010-2-051

01-005-002-31-0      15.02.2006

© HEIDOLPH INSTRUMENTS GMBH & CO KG

Technische Änderungen sind ohne vorherige Ankündigung vorbehalten.  
We reserve the right to make technical changes without prior announcement.  
Sous réserve de modifications techniques sans avis préalable.  
Se reserva el derecho de realizar modificaciones técnicas sin previo aviso.  
Ci riserviamo il diritto di apportare modifiche tecniche senza alcun preavviso.