

PERFORMANCE:

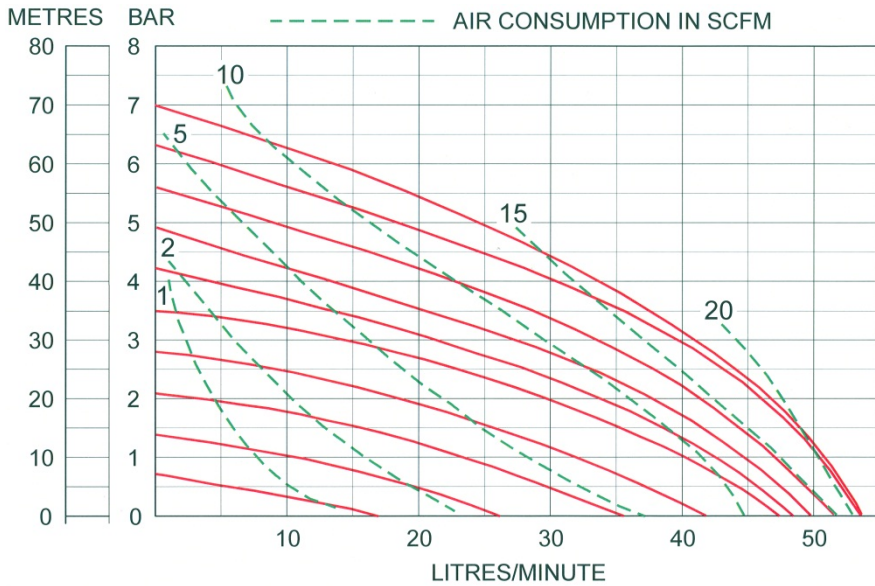

DIMENSIONS:

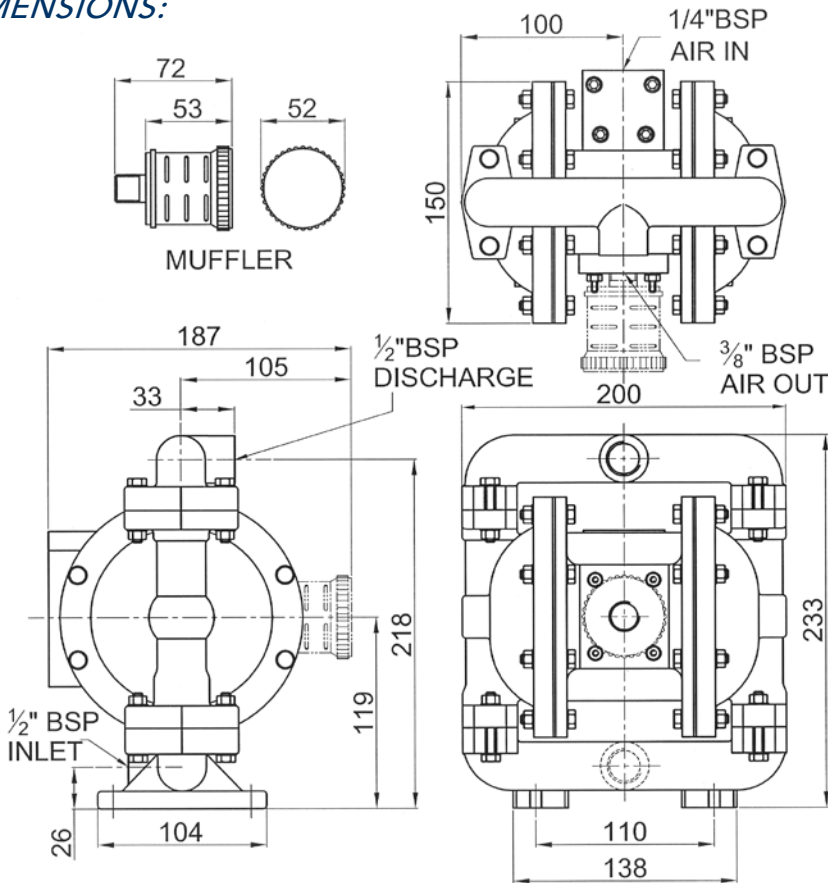

MATERIALS OF CONSTRUCTION:

WEIGHT: 6.8 Kg

| BODY | DIAPHRAGMS | BALL VALVES | VALVE SEATS | VALVE SEAT 'O' RINGS |
|-----------|------------|-------------|-------------|----------------------|
| Aluminium | PTFE | PTFE | Aluminium | PTFE |

OTHER ELASTOMERS AVAILABLE



TEP53-ATW-D

**1/2" BSP
AIR OPERATED
DOUBLE DIAPHRAGM
PUMP**



- ◆ Robust design
- ◆ Stall free performance
- ◆ Self-priming
- ◆ Can run dry without damage
- ◆ Oil free - no contamination
- ◆ Test certificate with every pump