

PERFORMANCE

Model	Maximum flow rate			Maximum head	
	l/min	cu.m/hr	gall/min	metres	feet
TS40D14	583	35	128	55	180

Maximum power absorbed 10.1kW at 2500rpm

DIMENSIONS IN MM (APPROX.)

WEIGHT: 21kg

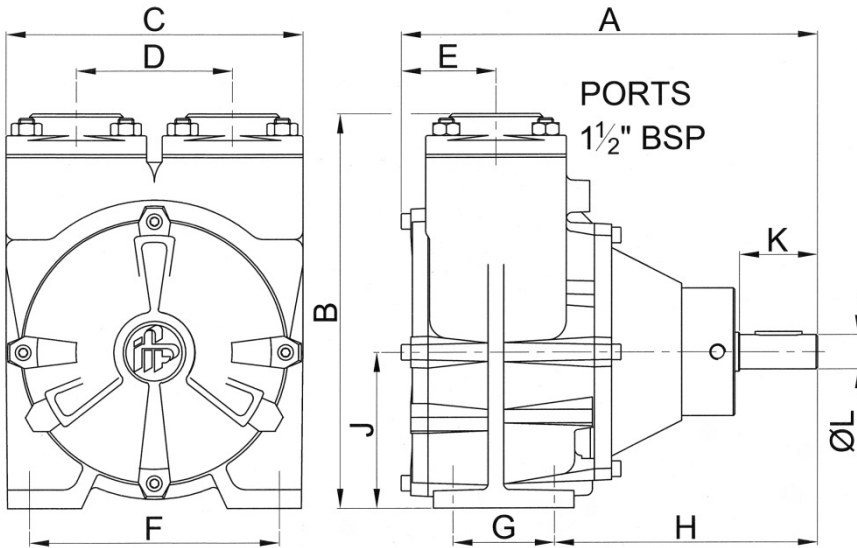

A	B	C	D	E	F	G	H	J	K	L
267	253	190	100	60.6	160	65	168.5	100	50	22

MATERIALS OF CONSTRUCTION

Pump casing	bronze
Impeller	bronze
Port counterflanges	Bronze
Shaft	stainless steel AISI316
Bearing housing	cast iron
Pump head bolts	stainless steel
O-ring static seal	nitrile rubber

Pump performance and specification are subject to alteration without notice

AVAILABLE 'A' series CLUTCHES (ask for a data sheet)

Clutch Type	Pulley Pitch Dia	Pulley Belt Section	No of Belts	FP Code
MANUAL	117mm	B	2	FP-94-8030611
MANUAL	140mm	B	2	FP-94-8050611
24v dc	152mm	SPB	1	FP-94-8110427
24v dc	145mm	A	2	FP-94-8130427

FP PUMPS

TS40D14

1 1/2" BRONZE SELF-PRIMING SIDE CHANNEL PUMP

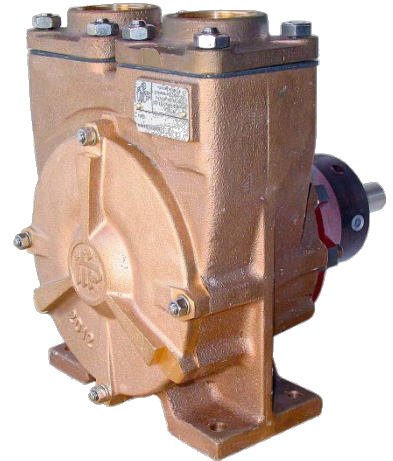

- ✦ reliable continuous duty pump
- ✦ corrosion-resistant bronze, with stainless steel shaft
- ✦ self-priming up to 4m
- ✦ flow can be reversed by a simple modification
- ✦ carbon-ceramic mechanical shaft seal

BRONZE PUMPS

for

SEAWATER

Xylem Water Solutions UK Ltd
Bingley Road
Hoddesdon
Hertfordshire • EN11 0BU • UK

Tel: +44 (0)1462 480380
Fax: +44 (0)1462 482422
mail@cleghorn.co.uk
www.jabscoshop.com

