

FORTE

FORTE BATTERY

LITHIUM MANGANESE DIOXIDE BATTERY

锂二氧化锰电池 | 型号: CR17505SE

Characteristics 性能数据

Nominal capacity(0.5mA-2.0v-25°C).....	2700mAh
标称容量	
Nominal voltage.....	3.0v
额定电压	
Max.constant current.....	15mA
最大连续工作电流	
Max.pulse current.....	150mA
最大脉冲电流	
Weight.....	30.0g
电池重量	
Volume.....	17.0X50.5mm
电池尺寸	
Workable temperature.....	-40°C~+85°C
工作温度	

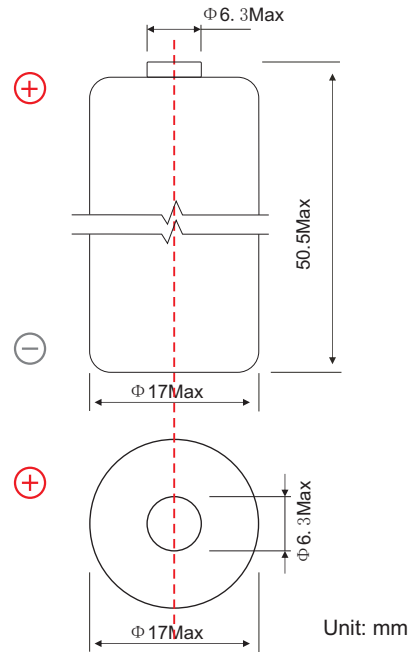
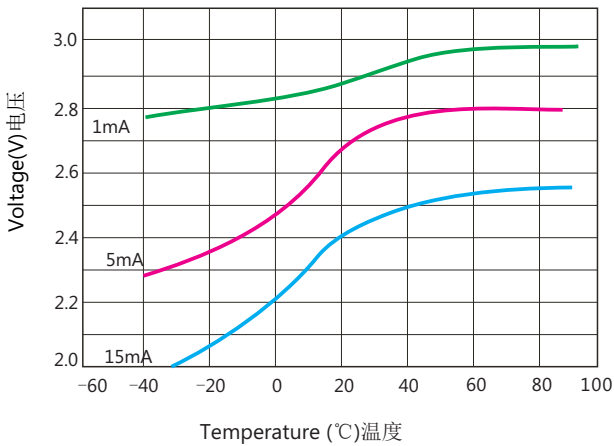
Temperature Characteristics 温度特性

极端样式可按照客户要求定做

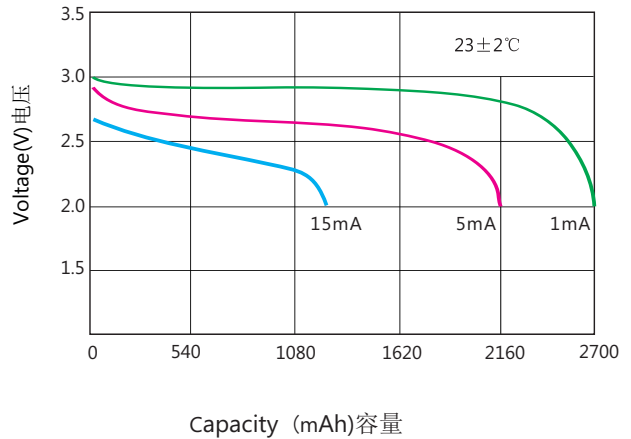
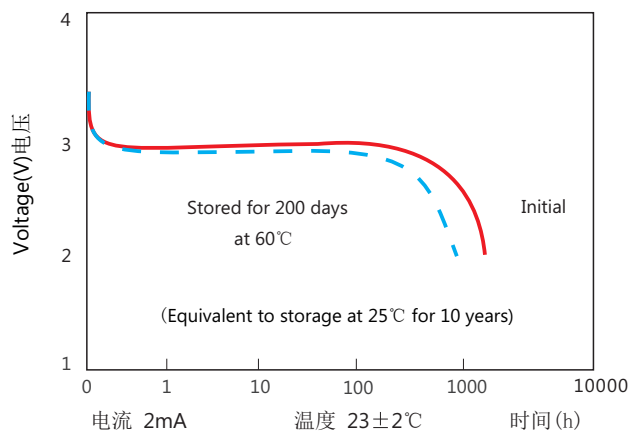
Discharge characteristic 放电特性**Storage characteristics 存储特性**

**АККУМУЛЯТОРНЫЕ
РЕШЕНИЯ**