

Dynapac CA2500D HC

Single drum vibratory rollers



Technical data

Masses	
Operating mass (incl. ROPS)	10200 kg
Operating mass (incl. Cab)	10400 kg
Module mass (front/rear)	5700/4700 kg
Max. operating mass	12000 kg

Dimensions	
Drum width	2130 mm

Traction	
Speed range	0 -12 km/h
Tyre size (8 ply)	23,1 x 26 AW
Theor. gradeability, forward	55 %
Theor. gradeability, reverse	55 %
Vertical oscillation	±9°

Compaction	
Static linear load	27 kg/cm
Nominal amplitude (high/low)	1.8 mm/0.9 mm
Vibration frequency (high/low amplitude) SEISMIC available (values for manual mode)	33 Hz /34 Hz
Centrifugal force (high/low amplitude)	250 kN/130 kN

Engine	
Manufacturer/Model	Cummins QSF3.8 (IV/4final)
Type	Water cooled turbo Diesel
Rated power, SAE J1995	89 kW (120 hp) @ 2,200 rpm
Fuel tank capacity	255 l
DEF tank capacity	20 l

Hydraulic system	
Driving	Hydrostatic
Vibration	Hydrostatic
Steering	Hydrostatic
Service brake	Hydrostatic in forward and reverse lever.
Parking/ Emergency brake	Failsafe multidisc brake in drum gear box and in rear axle.

Find us locally at www.dynapac.com

We reserve the right to change specifications without notice. Photos and illustrations do not always show standard versions of machines. The above information is a general description only, all informations are supplied without liability.

Dynapac CA2500D HC

Single drum vibratory rollers



Technical data

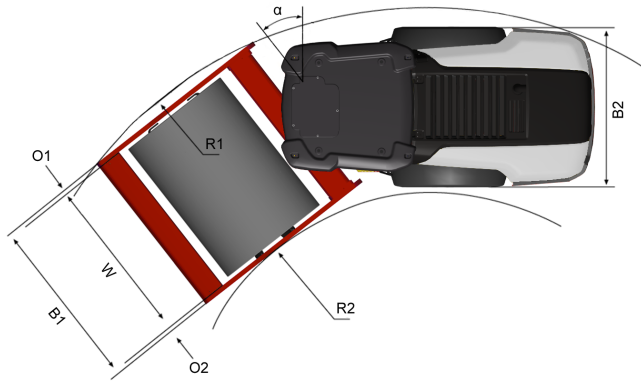
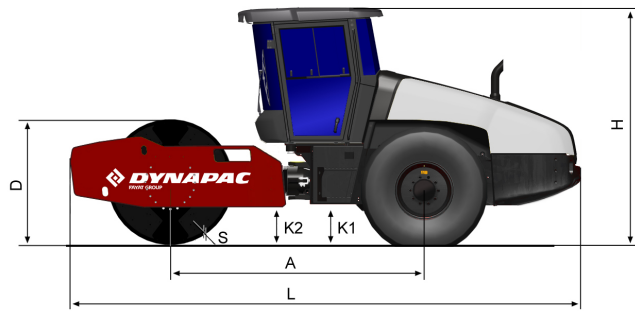

Dimensions	
A. Wheelbase	2990 mm
B1. Width, front	2300 mm
B2. Width, rear	2130 mm
D. Drum diameter	1500 mm
H. Height, with ROPS/cab	2870 mm
K1. Ground clearance	450 mm
K2. Curb clearance	450 mm
L. Length	5990 mm
O1. Overhang, right	105 mm
O2. Overhang, left	105 mm
R1. Turning radius, outside	5450 mm
R2. Turning radius, inside	3300 mm
S. Drum shell thickness	25 mm
W. Drum width	2130 mm
α. Steering angle	±38°

Find us locally at www.dynapac.com

We reserve the right to change specifications without notice. Photos and illustrations do not always show standard versions of machines. The above information is a general description only, all informations are supplied without liability.