



Operating Manual

Version 1.0.1

Bench drill

OPTIdrill[®]

DQ 14

Part no. 3191040

DQ 18

Part no. 3191042

DQ 22

Part no. 3191044
3191045



DQ 14



DQ 18



DQ 22



Table of contents

1	Safety	
1.1	Safety instructions (warning notes).....	5
1.1.1	Classification of hazards	5
1.1.2	Other pictograms.....	6
1.2	Intended use.....	7
1.3	Reasonably foreseeable misuses.....	7
1.3.1	Avoiding misuse.....	7
1.4	Possible dangers posed by the bench drill	8
1.5	Qualification	9
1.5.1	Target group private users	9
1.5.2	Obligations of the User.....	9
1.5.3	Additional requirements regarding the qualification	9
1.6	User positions.....	9
1.7	Safety measures during operation.....	9
1.8	Safety devices	9
1.9	Personal protective equipment	10
1.10	Safety check	10
1.11	Emergency stop switch.....	11
1.11.1	Drilling table	11
1.12	Separating protective devices.....	11
1.12.1	Drill chuck guard	11
1.12.2	Protective cover of the V-belts	11
1.12.3	Prohibition, warning and mandatory signs	12
1.13	Personal protective equipment	12
1.14	Safety during operation.....	12
1.15	Safety during maintenance	12
1.15.1	Disconnecting and securing the bench drill.....	13
1.15.2	Mechanical maintenance	13
1.16	Electronics	13
1.17	Inspection deadlines.....	13
2	Technical specification	
2.1	Emissions	15
2.2	Dimensions DQ14.....	16
2.3	Dimensions DQ18.....	17
2.4	Dimensions DQ22.....	18
3	Delivery, interdepartmental transport and unpacking	
3.1	Notes on transport, installation and unpacking.....	19
3.1.1	General risks during internal transport	19
3.2	Delivery.....	19
3.3	Unpacking.....	19
3.3.1	Standard scope of delivery.....	20
3.4	Installation requirements.....	20
3.4.1	Fixing.....	20
3.5	First commissioning	21
3.5.1	Warming up the machine	22
3.6	Electrical connection.....	22
3.6.1	DQ 14 ; DQ 18 ; DQ22 - 230V protective contact plug	22
3.6.2	DQ 22 - 400V CEE plug.....	22
4	Operation	
4.1	Control and indicating elements	23
4.1.1	DQ14 DQ18	23
4.1.2	DQ22.....	24
4.1.3	Control panel.....	25
4.2	Switching the machine on.....	25
4.3	Switching off the machine.....	25
4.4	Spindle quill feed	25
4.5	Drill depth stop.....	26
4.6	Table Inclination.....	26

DQ14_DQ18_DQ22_GBIVZ.fm



4.6.1	Table rotation - DQ22	26
4.7	Speed variation	27
4.7.1	DQ 14 and DQ 18	27
4.7.2	DQ 22	28
4.8	Before starting work	28
4.9	During work	28
4.10	Disassembly, assembly of drill chucks and drill bits	29
4.10.1	DQ14	29
4.10.2	DQ18 and DQ22	29
4.10.3	Fitting the drill chuck	30
4.11	Cooling	30
5	Determining the cutting speed and the speed	
5.1	Table cutting speeds / infeed	31
5.2	Speed table	31
6	Maintenance	
6.1	Safety	33
6.1.1	Preparation	33
6.1.2	Restarting	33
6.2	Inspection and maintenance	34
6.3	Repair	38
6.3.1	Customer service technician	38
7	Ersatzteile - Spare parts	
7.1	Ersatzteilbestellung - Ordering spare parts	39
7.2	Hotline Ersatzteile - Spare parts Hotline	39
7.3	Service Hotline	39
7.3.1	DQ14 - Bohrkopf - Drill head	40
7.3.2	DQ14 - Säule - Column	42
7.4	DQ14 - Schaltplan - Wiring diagram	43
7.4.1	DQ18 - Bohrkopf - Drill head	44
7.4.2	DQ18 - Säule - Column	46
7.5	DQ18 - Schaltplan - Wiring diagram	48
7.6	DQ22 - Bohrkopf - Drill head	49
7.6.1	DQ22 - Säule - Column	52
7.7	DQ22 - Schaltplan - Wiring diagram - 230V	53
7.8	DQ22 - Schaltplan - Wiring diagram - 400V	54
8	Malfunctions	
9	Appendix	
9.1	Copyright	56
9.2	Terminology/Glossary	56
9.3	Liability claims/warranty	56
9.4	Storage	57
9.5	Advice for disposal / Options of reuse:	57
9.5.1	Decommissioning	58
9.5.2	Disposal of new device packaging	58
9.5.3	Disposal of the old device	58
9.5.4	Disposal of electrical and electronic components	58
9.6	Disposal via municipal collection facilities	59
9.7	Change information operating manual	59
9.8	Product follow-up	59
9.9	Erwartete Genauigkeit - Expected accuracy	60



Preface

Dear customer,

Thank you very much for purchasing a product made by OPTIMUM.

OPTIMUM metal working machines offer a maximum of quality, technically optimum solutions and convince by an outstanding price performance ratio. Continuous enhancements and product innovations guarantee state-of-the-art products and safety at any time.

Before commissioning the machine please thoroughly read these operating instructions and get familiar with the machine. Please also make sure that all persons operating the machine have read and understood the operating instructions beforehand.

Keep these operating instructions in a safe place nearby the machine.

Information

The operating instructions include indications for safety-relevant and proper installation, operation and maintenance of the machine. The continuous observance of all notes included in this manual guarantee the safety of persons and of the machine.

The manual determines the intended use of the machine and includes all necessary information for its economic operation as well as its long service life.

In the paragraph "Maintenance" all maintenance works and functional tests are described which the operator must perform in regular intervals.

The illustration and information included in the present manual can possibly deviate from the current state of construction of your machine. Being the manufacturer we are continuously seeking for improvements and renewal of the products. Therefore, changes might be performed without prior notice. The illustrations of the machine may be different from the illustrations in these instructions with regard to a few details. However, this does not have any influence on the operability of the machine.

Therefore, no claims may be derived from the indications and descriptions. Changes and errors are reserved !

Your suggestion with regard to these operating instructions are an important contribution to optimising our work which we offer to our customers. For any questions or suggestions for improvement, please do not hesitate to contact our service department.

If you have any further questions after reading these operating instructions and you are not able to solve your problem with a help of these operating instructions, please contact your specialised dealer or directly the company OPTIMUM.

Optimum Maschinen Germany GmbH

Dr. Robert-Pfleger-Str. 26

D-96103 Hallstadt

Fax (+49)0951 / 96555 - 888



Email: info@optimum-maschinen.de

Internet: www.optimum-machines.com



1 Safety

Glossary of symbols

	provides further instructions
	calls on you to act
	listings

This part of the operating instructions

- explains the meaning and use of the warning notes included in these operating instructions,
- defines the intended use of the drilling machine,
- points out the dangers that might arise for you or others if these instructions are not observed,
- informs you about how to avoid dangers.

In addition to these operating instructions, please observe

- the applicable laws and regulations,
- the statutory provisions for accident prevention,
- the prohibition, warning and mandatory signs as well as the warning notes on the drilling machine.

Always keep this documentation close to the drilling machine.

INFORMATION

If you are unable to rectify an issue using these operating instructions, please contact us for advice:

Optimum Maschinen Germany GmbH
Dr.-Robert-Pfleger-Str. 26

D-96103 Hallstadt



email: info@optimum-maschinen.de



1.1 Safety instructions (warning notes)

1.1.1 Classification of hazards

We classify the safety warnings into different categories. The table below gives an overview of the classification of symbols (ideogram) and the warning signs for each specific danger and its (possible) consequences.

Symbol	Alarm expression	Definition / consequence
	DANGER!	Impending danger that will cause serious injury or death to people.
	WARNING!	A danger that can cause serious injury or death.
	CAUTION!	A danger or unsafe procedure that can cause personal injury or damage to property.
	ATTENTION!	Situation that could cause damage to the drilling machine and product, as well as other types of damage. No risk of injury to persons.

DQ14_DQ18_DQ22_GB_1.fm



Symbol	Alarm expression	Definition / consequence
	Information	Practical tips and other important or useful information and notes. No dangerous or harmful consequences for people or objects.

In case of specific dangers, we replace the pictogram with



general danger



with a warning of



injury to hands,



hazardous electrical voltage,

or



rotating parts.

1.1.2 Other pictograms



Warning: danger of slipping!



Warning: risk of stumbling!



Warning: hot surface!



Warning: biological hazard!



Warning: automatic start-up!



Warning: tilting danger!



Warning: suspended loads!



Caution, danger of explosive substances!



Switching on forbidden!



Use ear protection!



Read the operating instructions before commissioning!



Pull out the mains plug!



Wear protective glasses!



Wear protective gloves!



Wear safety shoes!



Wear a protective suit!



1.2 Intended use

WARNING!

If the drilling machine is not used as intended or if the safety directives or the operating instructions are ignored the liability of the manufacturer for any damages to persons or objects resulting hereof is excluded and the claim under guarantee is becoming null and avoid!



The bench drill is designed and manufactured to be used in a non-explosive environment. The bench drill is designed and manufactured for holes in cold metals or other non flammable materials or that not constitute a health hazard using a rotating filing-stripping tool that has a number of grooves for collecting the filings. The drilling machine is equipped with a drill chuck protection. The drill may only be operated with this chuck guard.

If the bench drill is used in any way other than described above, modified without authorization of Optimum Maschinen Germany GmbH, then the geared drill is being used improperly.

We will not be held liable for any damages resulting from any operation which is not in accordance with the intended use.

We explicitly point out that any construction, technical or process engineering changes that have not been approved by Optimum Maschinen Germany GmbH will render the warranty null and void

It is also part of intended use that the maximum values for the drilling machine are complied with and the operating manual is observed.

ATTENTION!

If the bench drill is not used as intended or if the safety directives or the operating instructions are ignored the liability of the manufacturer for any damages to persons or objects resulting hereof is excluded and the claim under guarantee is becoming null and avoid!



1.3 Reasonably foreseeable misuses

Any use other than that specified under "Intended use" or any use beyond that described will be deemed non-intended use and is not permissible. Any other use has to be discussed with the manufacturer.

It is only permissible to process metal, cold and non-inflammable materials with the bench drill.

In order to avoid misuse, it is necessary to read and understand the operating instructions before first commissioning.

Operators must be qualified.

1.3.1 Avoiding misuse

- Use of suitable cutting tools.
- Adapting the speed setting and feed to the material and workpiece.
- Clamp workpieces firmly and free of vibration.

ATTENTION!

The workpiece is always to be fixed by a machine vice, jaw chuck or by another appropriate clamping tool such as for the clamping claws.



WARNING!

Risk of injury caused by flying workpieces.

The table height adjustment must not be used as a drill feed. The clamping of the table is released, the possible load capacity of the table height adjustment is not intended for this.



DQ14_DQ18_DQ22_GB_1.fm



- ➔ Clamp the workpiece in the machine vice. Make sure that the workpiece is firmly clamped in the machine vice and that the machine vice is firmly clamped onto the drill table.
- Use cooling and lubricating agents to increase the durability of the tool and to improve the surface quality.
- Clamp the cutting tools and workpieces on clean clamping surfaces.
- Sufficiently lubricate the machine.
- Set the bearing clearance and guides correctly.

Recommendations:

- Insert the drill in a way that it is positioned exactly between the three clamping jaws of the drill chuck.

When drilling, make sure that

- the suitable speed is set depending on the diameter of the drill,
- the pressure must only be such that the drill can cut without load,
- if there is too much pressure, the drill will wear quickly and may even break or jam in the borehole. If the drill gets jammed immediately stop the main motor by pressing the emergency stop button,
- For hard materials, e.g. steel, it is necessary to use commercial cooling/lubricating agents. Basically, always pull out the drill with rotating spindle from the workpiece.
- The processing of plastics on the drilling machine leads to static charging. The static charging of machine parts due to the processing of plastics cannot be safely dissipated by the drilling machine.

1.4 Possible dangers posed by the bench drill

The bench drill is state-of-the-art. Nevertheless, there is a residual risk, as the bench drill operates with

- high speeds,
- rotating parts,
- electrical voltage and currents.
- We have used design and safety engineering to minimize the health risk to personnel resulting from these hazards.

If the bench drill is used and maintained by personnel who are not duly qualified, there may be a risk resulting from incorrect or unsuitable maintenance of the bench drill.

INFORMATION

Everyone involved in the assembly, commissioning, operation and maintenance must

- be duly qualified
- and strictly follow these operating instructions.

In the event of improper use

- there may be a risk to personnel,
- there may be a risk to the machine and other material values,
- the correct function of the bench drill may be affected.

Always disconnect the bench drill when cleaning or maintenance work is being carried out.

WARNING!

The bench drill may only be used with fully functional safety devices.

Disconnect the bench drill immediately, whenever you detect a failure in the safety devices or when they are not fitted!

This is your responsibility being the operator!





1.5 Qualification

1.5.1 Target group private users

The machine can be used in the private domain. The acumen of people in the private sector with training in metal working was taken into consideration for creating this operation manual. Vocational training or further instruction in a metal working profession is a prerequisite for safe operation of the machine. It is essential that the private user is aware of the dangers involved in operating this machine. We recommend attending a training course in the use of drills. Your specialist dealer can offer you an appropriate training course. These courses are also offered at adult education centres in Germany.

1.5.2 Obligations of the User

The user must

- have read and understood the operating manual,
- be familiar with all safety devices and regulations,
- be able to operate the drilling machine.

1.5.3 Additional requirements regarding the qualification

The following additional requirements apply for work on electrical components or equipment:

- They must only be performed by a qualified electrician or person working under the instructions and supervision of a qualified electrician.

Before starting work on electrical parts or operating agents, the following actions must be taken in the order given:

- ➔ disconnect all poles,
- ➔ secure against restarting,
- ➔ check that there is no voltage.

1.6 User positions

The operator position is in front of the drilling machine.

INFORMATION

The power plug of the bench drill must be readily accessible.



1.7 Safety measures during operation

CAUTION!

Danger due to inhaling dust and mist that is hazardous to health. Dependent on the material which need to be processed and the used auxiliaries dusts and mist may be caused which might impair you health. Ensure that the harmful dust and mist generated are safely sucked off at the point of origin and routed away from the working area or filtered. To do so, use a suitable extraction unit.



CAUTION!

Risk of fire and explosion by using flammable materials or cooling lubricants.

Before processing inflammable materials (e.g. aluminium, magnesium) or using inflammable auxiliary materials (e.g. spirit) it is necessary to take additional preventive measures in order to safely avoid health risks.



1.8 Safety devices

The bench drill must only be operated with fully functional safety devices.

Stop the bench drill immediately if there is a failure on the safety device or becomes ineffective.



It is your responsibility!

If a safety device has been activated or has failed, the bench drill must only be used if you

- the cause of the fault has been eliminated,
- have verified that there is no danger to personnel or objects.

WARNING!

If you bypass, remove or override a safety device in any other way, you are endangering yourself and other persons working with the bench drill. The possible consequences are:

- **injuries due to components or workpieces flying off at high speed,**
- **contact with rotating parts and**
- **fatal electrocution.**



The bench drill includes the following safety devices:

- an emergency stop push button,
- a drilling table with grooves for fixing the workpiece or a vice,
- a fixed protective cover for the pulleys with position switch,
- a foldable drill chuck guard.

WARNING!

Although the isolating safety devices provided and delivered with the machine are designed to reduce the risks of workpieces being ejected or parts of tools or workpieces breaking off, they cannot eliminate these risks completely. Always work carefully and observe the limits of the machining process.



1.9 Personal protective equipment

For certain work, personal protective equipment is required.

Protect your face and your eyes: Wear a safety helmet with facial protection when performing work where your face and eyes are exposed to hazards.



Wear protective gloves when handling pieces with sharp edges.



Wear safety shoes when you assemble, disassemble or transport heavy components.



Use ear protection if the noise level (emission) in the workplace exceeds 80 dB (A).

Before starting work make sure that the required personal protective equipment is available at the work place.



CAUTION!

Soiled personal protection equipment that may be contaminated may cause illness. It must be cleaned after each use and at least once a week.



1.10 Safety check

Check the bench drill before each start-up or at least once per shift. Inform the person responsible immediately of any damage, defects or changes in the operating function.

Check all safety devices

- at the beginning of each shift (with the machine stopped),
- once a week (with the machine in operation) and
- after all maintenance and repair work.

Check that prohibition, warning and information signs and the labels on the bench drill.



- are legible (clean them, if necessary)
- are complete (replace if necessary).

INFORMATION

Organise the checks according to the following table;



General check		
Equipment	check	OK
Guards	Mounted, firmly bolted and not damaged	
Signs, Markers	Installed and legible	
Date:	Checked by (signature):	

Functional check		
Equipment	check	OK
only on DQ22 - drill chuck guard	After opening the drill chuck guard, the DQ22 drill must switch off. The DQ22 drill must not start when the chuck guard is open.	
Emergency stop button	After actuating the emergency stop switch, the bench drill must switch off.	
Position switch of protective cover V-belt	The bench drill must not be switched on, if the protective cover of the V-belts is opened.	
Date:	Checked by (signature):	

1.11 Emergency stop switch

CAUTION!

The drilling spindle keeps turning for a short time even after actuating the emergency stop switch depending on the preset speed.



1.11.1 Drilling table

Seats for T-slots are attached to the clamping table.

WARNING!

Risk of injury due to workpieces flying off at high speed. Securely fix the workpiece on the drilling table.



1.12 Separating protective devices

1.12.1 Drill chuck guard

Adjust the guard to the correct height before you start working. To do this, loosen the clamping screw, set the required height and tighten the clamping screws again.

1.12.2 Protective cover of the V-belts

A protective cover for the belt pulleys is mounted on the drilling head. There is a switch integrated in the protective cover which monitors that the cover is closed.

DQ14_DQ18_DQ22_GB_1.fm



INFORMATION

The machine cannot be started, if the protective cover is not closed.



1.12.3 Prohibition, warning and mandatory signs

INFORMATION

All warning signs must be legible. They must be checked regularly.



1.13 Personal protective equipment

For some works you need personnel protective equipment as protective equipment. These are

- safety helmet,
- protective glasses or face guard,
- protective gloves,
- safety shoes with steel toe caps,
- ear protection.

Before starting work make sure that the required personnel protective equipment is available at the work place.

CAUTION!

Soiled personal protection equipment that may be contaminated may cause illness. It must be cleaned after each use and at least once a week.



Personal protective equipment for special works

Protect your face and your eyes: Wear safety glasses for all work where your eyes are at risk.

Wear protective gloves when handling pieces with sharp edges.

Wear safety shoes when you assemble, disassemble or transport heavy components.

1.14 Safety during operation

We specifically point out the dangers in the description of work with and on the bench drill.

WARNING!

Before activating the bench drill, double-check that make sure that there are no dangers generated for persons, not cause damage to equipment.



Avoid any unsafe work methods.

- Make sure that your work does not endanger anyone.
- The instructions described in these operating instructions must be strictly observed during assembly, operation, maintenance and repair.
- Do not work on the bench drill if your concentration is reduced, for example, because you are taking medication.
- Inform the supervisor about all hazards or faults.
- Stay on the bench drill until the machine completely stopped moving.
- Use the specified personal protective equipment. Ensure you wear close-fitting clothing and, if necessary, a hairnet.
- Do not use protective gloves when drilling.

1.15 Safety during maintenance

Inform the operators in good time of any maintenance and repair works.

Report all safety relevant changes and performance details of the bench drill or their operational behaviour. Any changes must be documented, the operating instructions updated and machine operators instructed accordingly.



1.15.1 Disconnecting and securing the bench drill

Disconnect the mains plug before starting maintenance and repairs.

All machine parts as well as all dangerous voltages are switched off. Excepted are only the positions which are marked with the adjoining pictogram.

Attach a warning sign to the machine.

1.15.2 Mechanical maintenance

Remove or install protection safety devices before starting or after completing any maintenance work; this include:

- covers,
- safety instructions and warning signs,
- grounding cables.

If you remove protection or safety devices, refit them immediately after completing the work. Check that they are working properly!

1.16 Electronics

Craftsman or industrial use

Have the machine and/or the electric equipment checked regularly. Immediately eliminate all defects such as loose connections, defective wires, etc.

A second person must be present during work on live components to disconnect the power in the event of an emergency. If there is a fault in the power supply, switch off the milling machine immediately!

Comply with the required inspection intervals in accordance with the factory safety directive, operating equipment inspection.

The operator of the machine must ensure that the electrical systems and operating equipment are inspected with regards to their proper condition, namely,

- by a qualified electrician or under the supervision and direction of a qualified electrician, prior to initial commissioning and after modifications or repairs, prior to recommissioning
- and at set intervals.

The deadlines must be set so that arising, foreseeable defects can be detected in a timely manner.

The relevant electro-technical rules must be followed during the inspection.

No check is required before first commissioning, if the manufacturer or installer has confirmed to the operator that the electrical system and operating materials have been procured in accordance with the stipulations of the accident prevention regulations.

Permanently installed electrical systems and operating materials are considered constantly monitored if they are continually serviced by qualified electricians and inspected by means of measurements during operation (e.g. monitoring the insulation resistance).

1.17 Inspection deadlines

Technical or Industrial Use

Define and document the inspection deadlines for the machine in accordance with § 3 of the Factory Safety Act and perform an operational risk analysis in accordance with § 6 of the Work Safety Act. Also use the inspection intervals in the maintenance section as reference values.

DQ14_DQ18_DQ22_GB_1.fm



2 Technical specification

The following information represents the dimensions and indications of weight and the manufacturer's approved machine data.

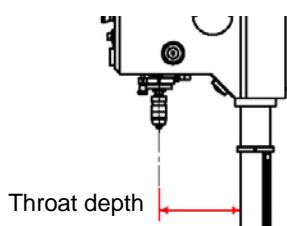
	DQ 14	DQ 18	DQ 22
Electrical connection	230V~50 Hz (~60Hz)	230V~50 Hz (~60Hz)	230V~50 Hz (~60Hz) 400V~50 Hz (~60Hz)
Spindle drive motor power	350 W	450 W	550 W
Drilling capacity in steel (ST60 - E335) [mm]	Ø 13	Ø 15.9	Ø 16
 Throat depth	104 mm	127 mm	169 mm
Spindle sleeve travel [mm]	52	65	85
Spindle seat	B16	MT2	MT2
Table size Length x Width of the working surface	170mm x 170mm	200mm x 200mm	270mm x 270mm
Tilting the table to the side / Table turn around drill column	± 45° / 360°	± 45° / 360°	± 45° / 360°
Rotating the table in the holder	-	-	360°
Drilling table T-slot size [mm]	14 mm diagonal	14 mm diagonal	14 mm diagonal
Table load max.	8 kg	12 kg	15 kg
T-slot size machine base	14 mm	14 mm	14 mm
Distance spindle - table [mm]	max. 250 mm	max. 319 mm	max. 460 mm
Maximum distance [mm] spindle - stand	max. 340 mm	max. 518 mm	max. 639 mm
Working surface machine stand [mm] Length x Width of the working surface	138 x 128 mm	145 x 143 mm	191 x 187 mm
Dimensions of the machine	📖 Page 16	📖 Page 17	📖 Page 18
Required space			
Net machine weight [kg]	18.5	28.3	41.7
Spindle speeds [rpm]	700 870 1390 1900 2500	600 680 850 1350 2400	300 370 450 500 550 640 950 1100 1300 1400 1900 2300
V-belt speed steps	5	5	12
Column diameter [mm]	Ø 46	Ø 60	Ø 70
Environmental conditions temperature	5 ~ 35 °C		

DQ14_DQ18_DQ22_GB_2.fm



	DQ 14	DQ 18	DQ 22
Environmental conditions Relative humidity	25 - 80 %		
Operating equipment, toothed rack and oiler Operating equipment,, toothing on the spindle	Acid-free lubricating oil Assembly grease for clearance fits, e.g. Staburag NBU 30 PTM		

2.1 Emissions

CAUTION!

Depending on the overall noise exposure and the basic threshold values, machine operators must wear appropriate hearing protection.

We generally recommend the use of noise and ear protection.

The A-weighted sound pressure level L_{pA} is 73 to 75 dB.

The A-weighted sound power level L_{WA} is 98 to 102 dB.



INFORMATION

This numerical value was measured on a new machine under the operating conditions specified by the manufacturer. The noise behaviour of the machine might change depending on the age and wear of the machine.

Furthermore, the noise emission also depends on production engineering factors, e.g. speed, material and clamping conditions.



INFORMATION

The following factors influence the actual degree of the noise exposure of the operator:

- Characteristics of the working area, e.g. size of damping behaviour,
- other noise sources, e.g. the number of machines,
- other processes taking place in proximity and the period of time, during which the operator is exposed to the noise.

Furthermore, it is possible that the admissible exposure level might be different from country to country due to national regulations.

This information about the noise emission should, however, allow the operator of the machine to more easily evaluate the hazards and risks.





2.2 Dimensions DQ14

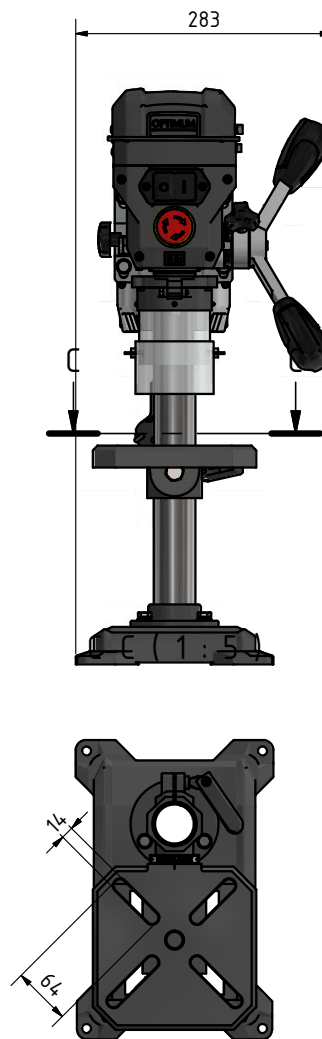
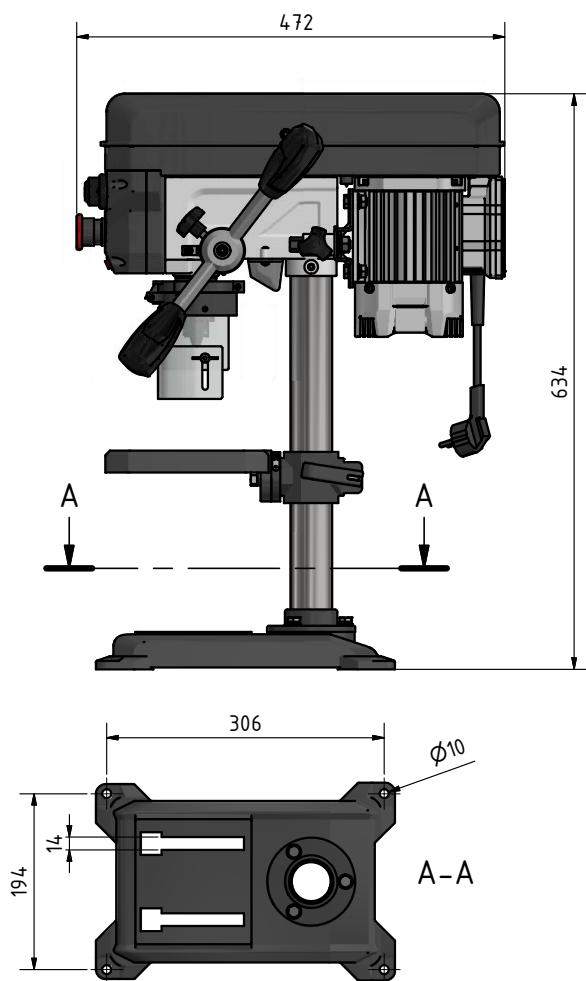



2.3 Dimensions DQ18

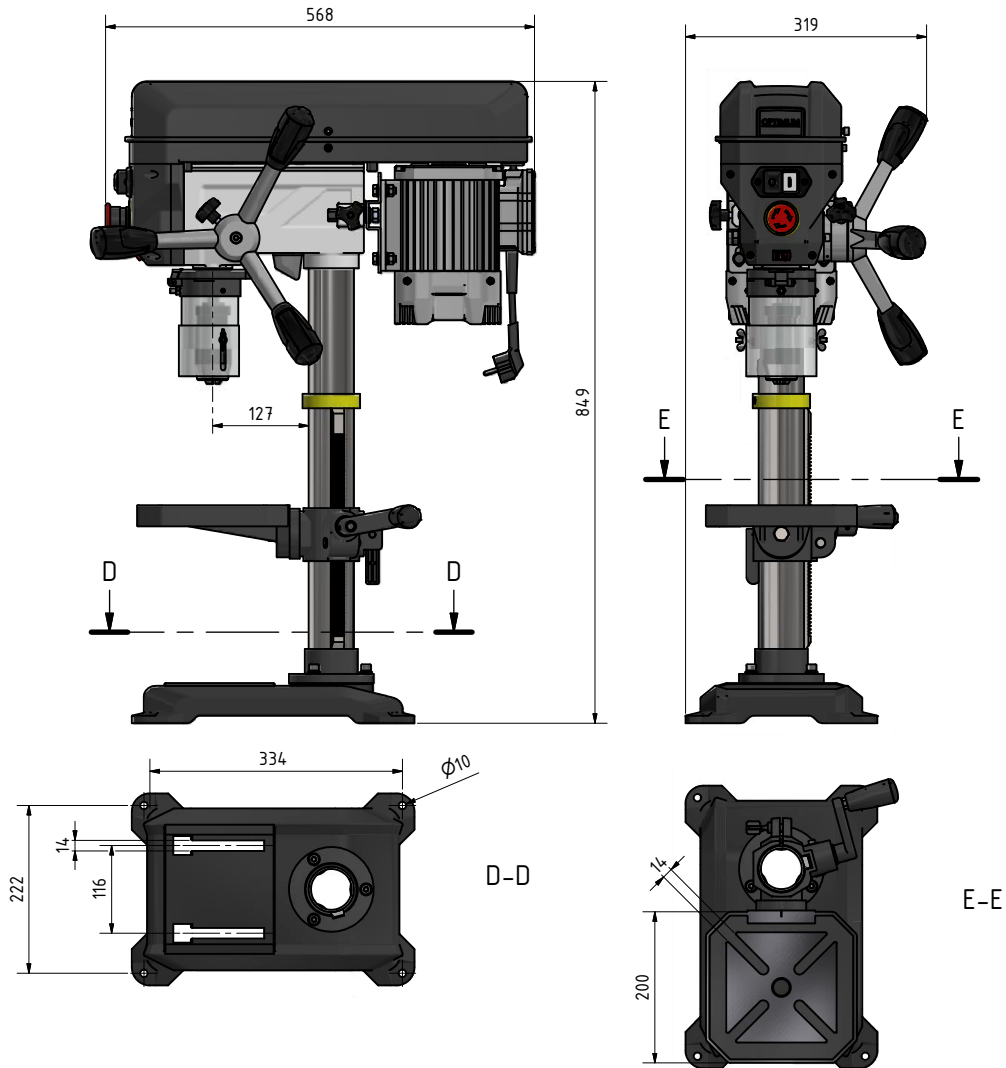

DQ14_DQ18_DQ22_GB_2.fm



2.4 Dimensions DQ22

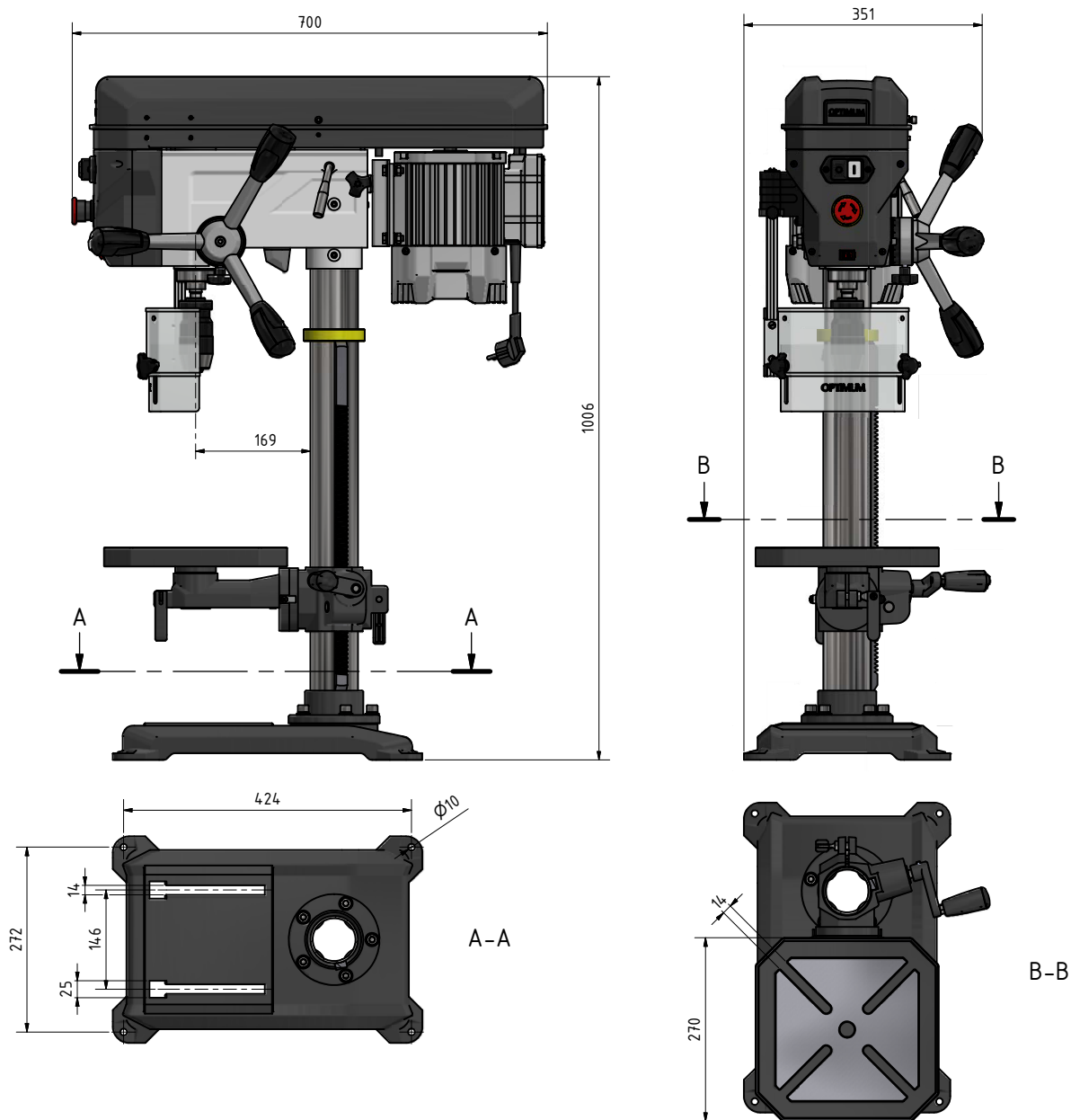

DQ14_DQ18_DQ22_GB_2.fm



3 Delivery, interdepartmental transport and unpacking

CAUTION!

Injuries caused by parts falling over or off a forklift, pallet truck or transport vehicle. Only use means of transport that can carry the total weight and are suitable for it.



3.1 Notes on transport, installation and unpacking

Improper transport of individual devices and minor machines, unsecured devices and minor machines stacked on top of each other or next to each other in packed or already unpacked condition is accident-prone and can cause damage or malfunctions for which we do not grant any liability or guarantee.

Transport the scope of delivery secured against shifting or tilting with a sufficiently dimensioned industrial truck to the installation site.

3.1.1 General risks during internal transport

CAUTION: DANGER OF TIPPING!

The device may be lifted unsecured by a maximum of 2cm.

Employees must be outside the danger zone, the reach of loads. Warn employees and, if necessary, advise employees of the hazard.



Act responsibly during transport and always consider the consequences. Refrain from daring and risky actions.

Gradients and descents (e.g. driveways, ramps and the like) are particularly dangerous. If such passages are unavoidable, special caution is required.

Before starting the transport check the transport route for possible danger points, unevenness and disturbances as well as for sufficient strength and load capacity.

Danger points, unevenness and disturbance points must be inspected before transport. The removal of danger spots, disturbances and unevenness at the time of transport by other employees leads to considerable dangers.

Careful planning of internal transport is therefore essential.

3.2 Delivery

Check the status of the machine immediately upon receipt and claim possible damages at the last carrier also if the packing is not being damaged. In order to ensure claims towards the freight carrier we recommend you to leave the machines, devices and packing material for the time being in the status at which you have determined the damage or to take photos of this status. Please inform us about any other claims within six days after receipt of delivery.

3.3 Unpacking

Place the machine near its final location before proceeding to unpack. If the packaging shows signs of having possibly been damaged during transport, take the appropriate precautions to prevent the machine being damaged when unpacking. If damage is discovered, the carrier and/or shipper must be notified immediately so the necessary steps can be taken to register a complaint.

Examine the complete machine carefully and check whether all materials, such as shipping documents, instructions and accessories have been delivered with the machine.



3.3.1 Standard scope of delivery

Bench drill DQ 14

- Drill chuck B16 for drills 0 to 13mm

Bench drill DQ 18

- Drill chuck B16 for drills 0 to 15.9mm
- Morse taper MT2 / B16

Bench drill DQ 22

- Drill chuck B16 for drills 0 to 16mm
- Morse taper MT2 / B16

3.4 Installation requirements

Organise the working area around the machine according to the local safety regulations. The work area for operation, maintenance and repair must not be restrictive.

The illumination of the workplace must be designed in such a manner that an illumination of 500 Lux is attained at the tool tip.

If this is not guaranteed with the normal installation site lighting, workplace lights (available as an option) must be used.

- Follow the prescribed safety areas and escape routes according to VDE 0100 part 729 as well as the environmental conditions for the operation of the machine.
- The mains plug or the main switch of the machine installed by the operator must be freely accessible.
- The machine must only be installed and operated in a dry and well-ventilated place.
- Avoid places near machines generating chips or dust.
- The installation site must be free from vibrations also at a distance of presses, planing machines, etc.
- Provide sufficient space for the personnel preparing and operating the machine and transporting the material.
- Also make sure the machine is accessible for setting and maintenance works.

3.4.1 Fixing

In order to provide for the necessary stability of the drilling machine, connect the machine with its foot to the substructure.

- ➔ Fix the foot of the drilling machine to the substructure with the holes pre-drilled for this purpose.

ATTENTION!

Tighten the fixing screws of the drilling machine only as much that it is safely fixed and cannot break away or tilt over.

If the fixing screws are too tight in particular in connection with an uneven substructure it may result in a broken stand of the machine.



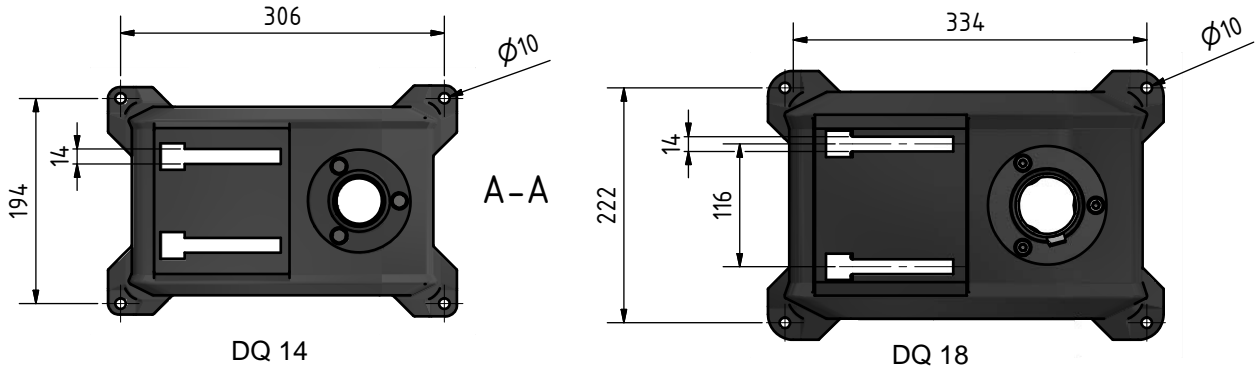

Img.3-1:

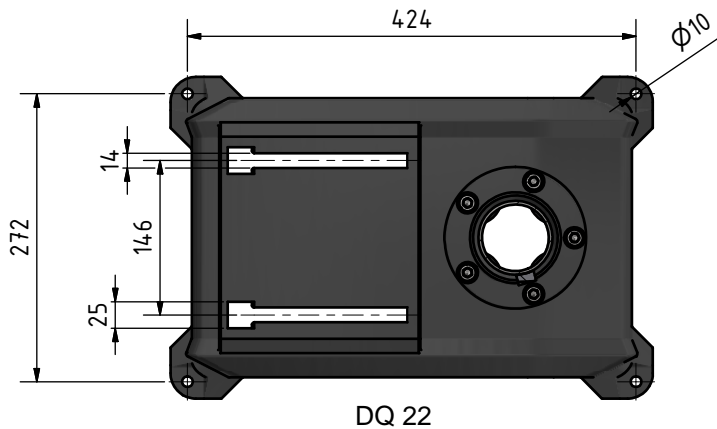

Img.3-2:

3.5 First commissioning

CAUTION!

First commissioning may only take place after proper installation.



WARNING!

The use of improper tool holders or their operation at inadmissible speeds constitutes a hazard.

Only use the tool holders (e.g. drill chuck) which were delivered with the machine or which are offered as optional equipment by OPTIMUM.

Only use tool holders in the intended admissible speed range.

Tool holders may only be modified in compliance with the recommendation of OPTIMUM or of the manufacturer of the clamping devices.

WARNING!

There is a danger to persons and equipment, if the first commissioning of the drilling machine is carried out by inexperienced personnel.

We do not accept any liability for damages caused by incorrectly performed commissioning.



DQ14_DQ18_DQ22_GB_3.fm



3.5.1 Warming up the machine

ATTENTION!

If the drilling machine and in particular the drilling spindle is immediately operated at maximum load when it is cold it may result in damages.

If the machine is cold, e.g. directly after having transported the machine, it should be warmed up at a spindle speed of only 500 1/min for the first 30 minutes.



3.6 Electrical connection

3.6.1 DQ 14 ; DQ 18 ; DQ22 - 230V protective contact plug

CAUTION!

Position the power lead for the machine in such a manner that people cannot trip over it.



3.6.2 DQ 22 - 400V CEE plug

CAUTION!

Position the power lead for the machine in such a manner that people cannot trip over it.



ATTENTION!

Imperatively make sure that all 3 phases (L1, L2, L3) are correctly connected.

Most motor defects result of wrong connections. For instance if a motor phase is not correctly clamped or connected to the neutral conductor (N).

Effects may be as follows:

- The motor is getting hot very rapidly.
- Increased motor noises.
- The motor has no power.



ATTENTION!

Make sure that the direction of rotation of the drive motor is correct. The switch position of the rotation selector switch for right-handed rotation (R) has to turn the drill spindle clockwise. If necessary, exchange two phase connections. The guarantee will become null and void if the machine is connected incorrectly.





4 Operation

4.1 Control and indicating elements

4.1.1 DQ14 | DQ18

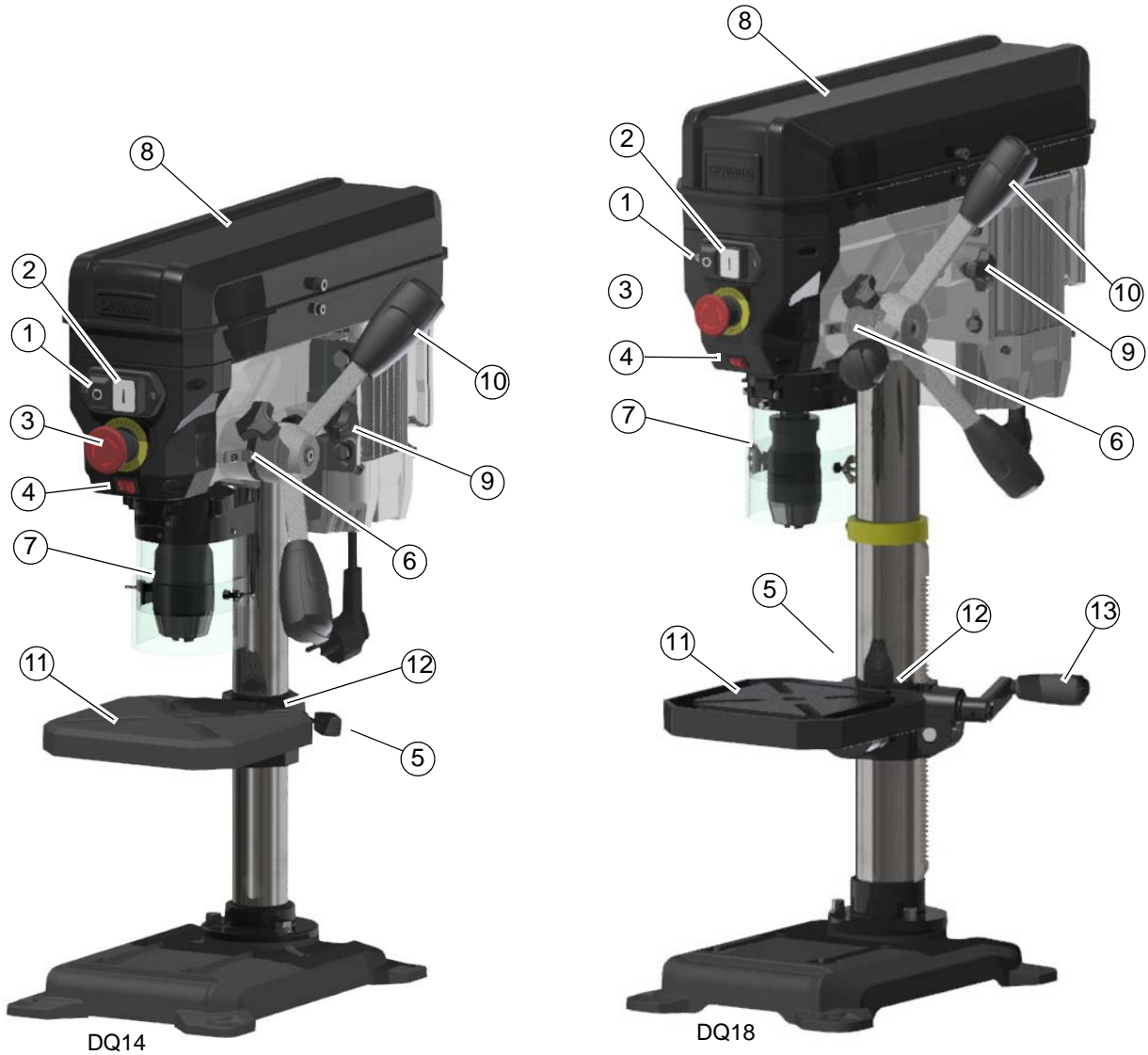

Img.4-1: DQ14 | DQ 18

Pos.	Designation	Pos.	Designation
1	Push button "Off"	2	Push button "On"
3	Emergency-stop switch	4	Machine illumination
5	Clamping lever drilling table	6	Scale of drill depth stop
7	Drill chuck protection, drill chuck	8	Protective cover of V-belt housing
9	V-belt tension clamping screw right	10	Lever for spindle sleeve feed
11	Drilling table	12	Table tilt scale
13	Hand crank table height adjustment (DQ18 only)		

DQ14_DQ18_DQ22_GB_4.fm



4.1.2 DQ22

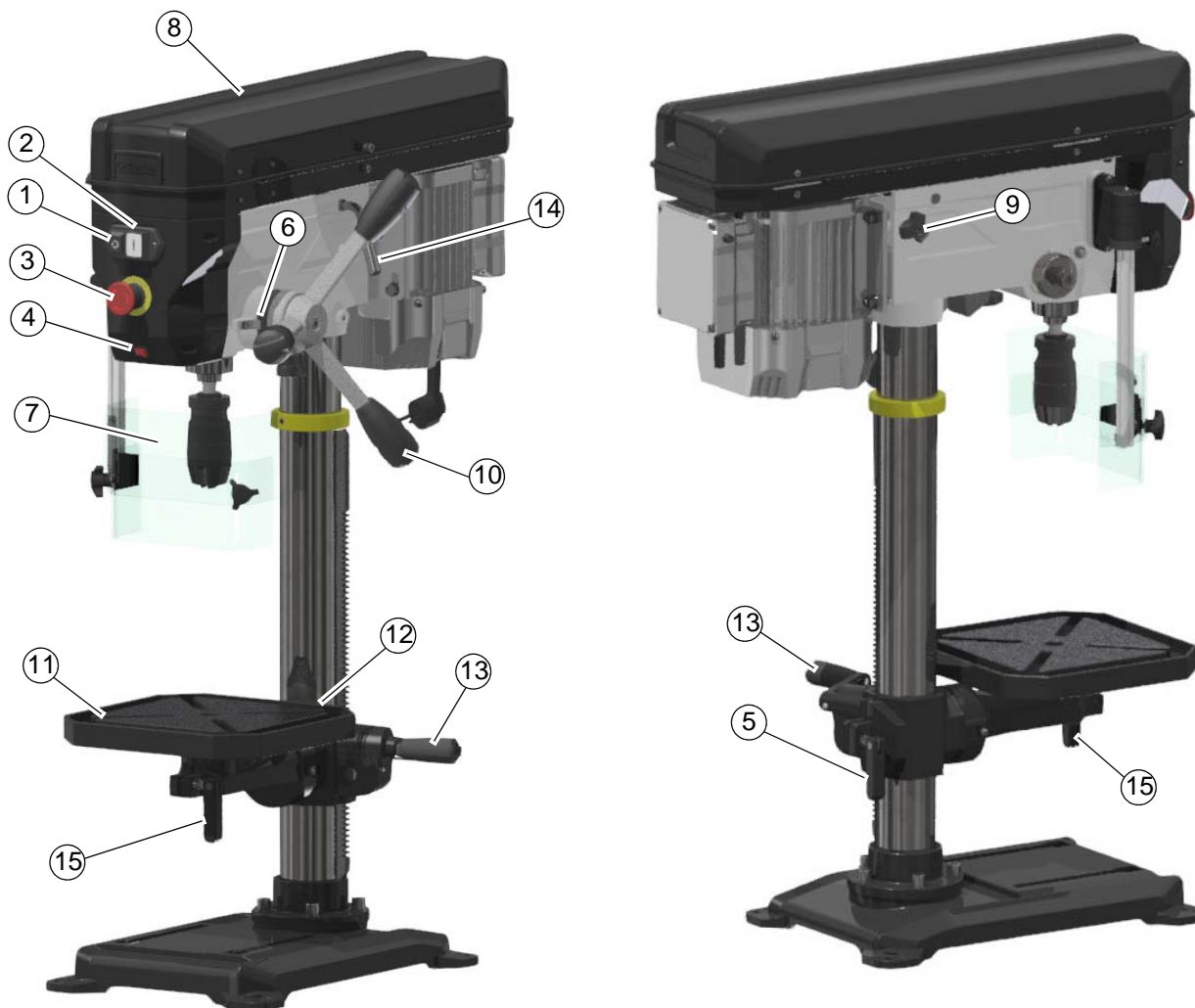

Img.4-2: DQ22 - 230V

Pos.	Designation	Pos.	Designation
1	Push button "Off"	2	Push button "On"
3	Emergency-stop switch	4	Machine illumination
5	Clamping lever drilling table	6	Scale of drill depth stop
7	Drill chuck protection, drill chuck	8	Protective cover of V-belt housing
9	V-belt tension clamping screw left	10	Lever for spindle sleeve feed
11	Drilling table	12	Table tilt scale
13	Hand crank table height adjustment	14	Lever V-belt tensioning
15	Turn table clamping lever	16	Rotary direction switch (DQ22 - 400V only)

DQ14_DQ18_DQ22_GB_4.fm



4.1.3 Control panel

Push button ON

The push button "ON" switches on the rotation of the drilling spindle.

Push button Off

The "push button OFF" switches the rotation of the drilling spindle off.

Machine light switch

Switches the machine light on or off.

Rotary direction switch

Switches the rotational direction of spindle on DQ22 - 400V machine.

4.2 Switching the machine on

INFORMATION

As long as the drill chuck guard on the DQ22 is not closed, the bench drill DQ22 cannot be started.

On the bench drill DQ14 and DQ18 there is no switch in the drill chuck guard.

- Determine and adjust the position of the V-belt. Close the cover of the V-belt cover again with the screw plug.
- Set the height of drill chuck guard and close the drill chuck guard.
- Switching the machine on



4.3 Switching off the machine

CAUTION!

Only press the emergency-stop button in a genuine emergency. You should not use the emergency stop button to stop the machine during normal operation.

- Actuate the push button "OFF".
- Pull the plug for a longer-term standstill.



4.4 Spindle quill feed

CAUTION!

Risk of impact by the spindle sleeve lever upon completion of the drilling feed. The return spring biases and discharges the stored energy.

- Move the sleeve downward by means of the spindle sleeve lever. The sleeve is returned to its initial position by means of the spring force.





4.5 Drill depth stop

→ Loosen the clamping screw and turn the scale ring to the desired drilling depth.

→ Tighten the clamping screw again.

The spindle can only be lowered to the set value.

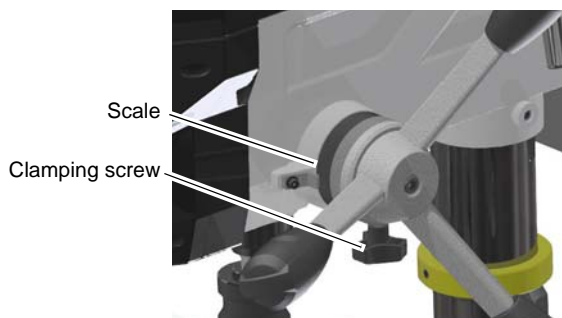

Img.4-3: Scale of drill depth stop

4.6 Table Inclination

CAUTION!

The further the drilling table is tilted to the left or right, the lower the carrying capacity and the clamping action of the inclined drilling table.

The drilling table can be inclined to the right or to the left.

→ Loosen fixing screw (1).

→ Set the desired angle using the scale.

→ Tighten the fixing screw again.



4.6.1 Table rotation - DQ22

→ DQ22 only. Release the clamping lever (2) and turn the table to the desired position.

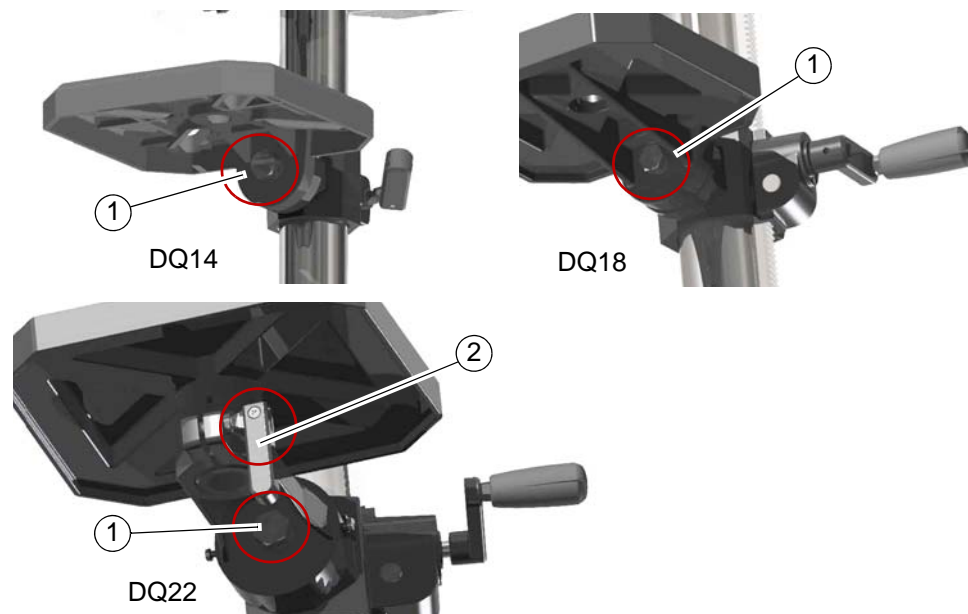

When the angle scale with zero degree marking on the drilling table is not sufficient for the desired accuracy. If necessary, use an angular stop or dial gauge to set the table in a desired position.

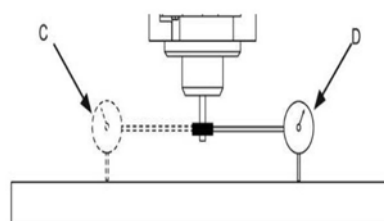

DQ14_DQ18_DQ22_GB_4.fm



4.7 Speed variation

CAUTION!

Preventive safety measure. Disconnect the machine from the power supply.

ATTENTION!

Watch for the proper tension of V-belts.

Too heavy or too low tension of the belt can cause damage.

The belts are correctly tensioned, when it can be by pressing with the fingers for about 1 cm.

- Disconnect the machine from the power supply.
- Loosen the screw plug (1) on the V-belt protective cover.
- Fold the protective cover (2) back.

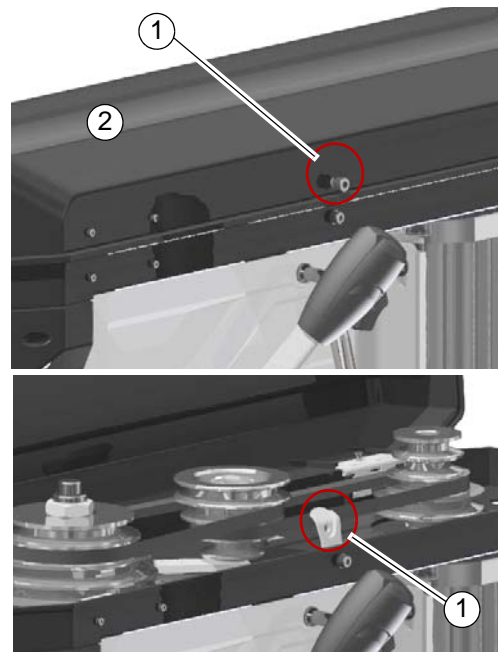

4.7.1 DQ 14 and DQ 18

- Loosen the clamping screw (3) on both sides and release the V-belt tension. If necessary, move the motor by hand.
- Set the V-belt (4) to the desired position of the V-belt pulleys.

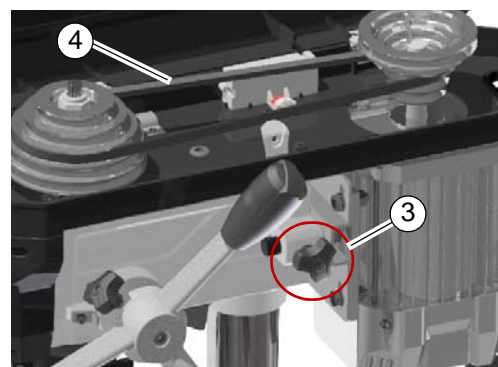
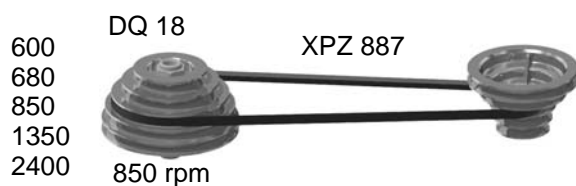
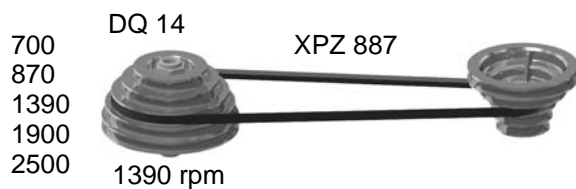

DQ14_DQ18_DQ22_GB_4.fm



4.7.2 DQ 22

Pay attention to the correct position of the different lengths of the V-belts!

The slightly shorter V-belt belongs to the spindle pulley.

- ➔ Loosen clamping screw (3) on both sides.
- ➔ Release the V-belt tension with the lever (5).
- ➔ Set the V-belts (4) to the desired position of the V-belt pulleys.

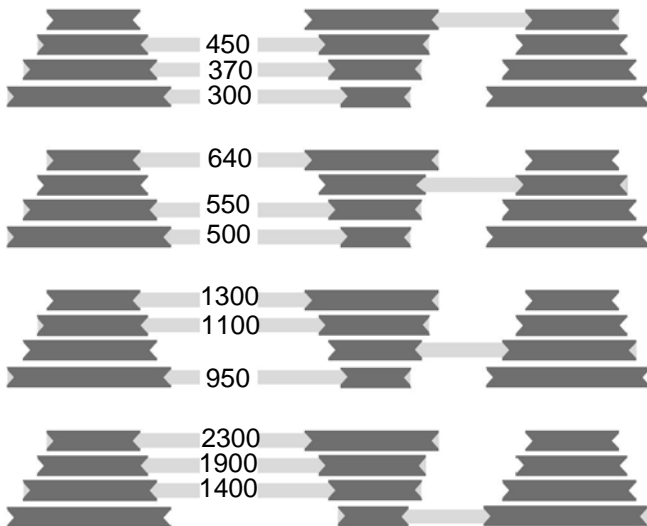
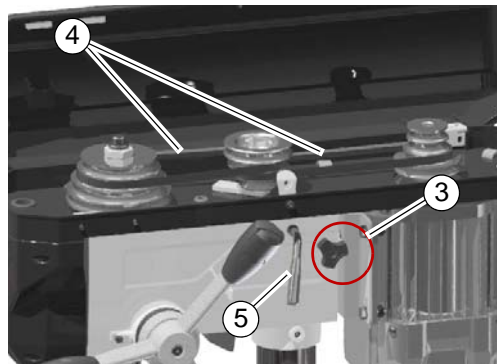
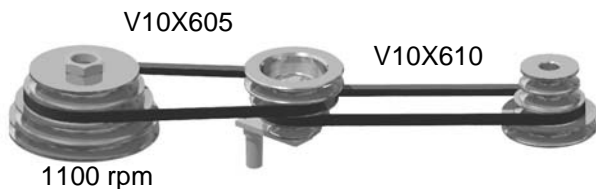

4.8 Before starting work

WARNING!

For drilling jobs, it is necessary to clamp the workpiece firmly to prevent the bit catching on the pieces. A machine vice or clamping claws is a suitable clamping device.

Before starting work, select the desired speed. It is depending on the used drilling diameter and on the material.

If required, adjust the desired drilling depth by means of the drilling depth stop in order to obtain a uniform drilling depth.



4.9 During work

WARNING!

Seizing of clothes and / or hair.

- Make sure to wear well-fitting work during drilling work.
- Do not use gloves.
- If necessary, use a hairnet.

The smaller the bit the more easily it may break. In the case of deep drilling, remove the bit from time to time to remove filings from the drill. Add a few drops of oil to reduce friction and prolong the service life of the bit.





4.10 Disassembly, assembly of drill chucks and drill bits

CAUTION!

Preventive safety measure. Disconnect the machine from the electrical supply.

ATTENTION!

The tool and/or the drill chuck will fall down. Hold the tool or the drill chuck while drifting it out.



4.10.1 DQ14

The drill chuck on the DQ14 is attached directly to the spindle (1). Cone connection B16.



Img.4-4:

4.10.2 DQ18 and DQ22

The drill chuck on the DQ18 and DQ22 bench drill is mounted on an MT2 taper arbor. Taper mandrels can be disassembled with a common drill drift. Use a drift wedge or a commercially available drift punch to loosen the taper connection between spindle (1) and taper mandrel (3).

- Disconnect the machine from the electrical supply. Pull out the mains plug.
- Turn the drilling spindle (1) until the openings (4) of the sleeve and of the drilling spindle are superimposed.
- Hold the tool with your hand.
- Release the tool from the drill spindle with a drift punch.
- Hold the tool by hand and remove it from the conical seat.



Img.4-5:



4.10.3 Fitting the drill chuck

Only a clean and smooth surface allows a correct and tight fitting connection.

On the bench drill DQ14, the drill chuck is pressed onto the taper B16.

On the DQ18 and DQ22 bench drills, the drill chuck is secured against rotation in the drill spindle by a positive-locking connection (driver). A frictionally engaged connection keeps and centres the drill chuck or the drill in the drill spindle.

4.11 Cooling

The friction generated during rotation can cause the edge of the tool to become very hot.

The tool should be cooled during the drilling process. Cooling the tool with a suitable cooling lubricant ensures better working results and a longer edge life of the tools. This is best realised by a separate cooling equipment. If there is no cooling equipment included in the delivery volume, you can cool by means of a spray gun or a washing bottle.

CAUTION!

Danger of injury due to brushes getting caught or pulled in. Use a spray gun or a washing bottle for cooling.



INFORMATION

Use a water-soluble and non-pollutant emulsion as a cooling agent. This can be acquired from authorised distributors.

Make sure that the cooling agent is being collected.

Respect the environment when disposing of lubricants and coolants.

Follow the manufacturer's disposal instructions.





5 Determining the cutting speed and the speed

5.1 Table cutting speeds / infeed

Material table	Recommended infeed f in mm/revolution					
Material to be processed	Recommended cutting speed Vc in m/min	Drill bit diameter d in mm				
		2...3	>3...6	>6...12	>12...25	>25...50
Unalloyed construction steels < 700 N/mm ²	30 - 35	0.05	0.10	0.15	0.25	0.35
Alloyed construction steels > 700 N/mm ²	20 - 25	0.04	0.08	0.10	0.15	0.20
Alloyed steels < 1000 N/mm ²	20 - 25	0.04	0.08	0.10	0.15	0.20
Steels, low stability < 800 N/mm ²	40	0.05	0.10	0.15	0.25	0.35
Steel, high stability > 800 N/mm ²	20	0.04	0.08	0.10	0.15	0.20
non-rust steels > 800 N/mm ²	12	0.03	0.06	0.08	0.12	0.18
Cast iron < 250 N/mm ²	15 - 25	0.10	0.20	0.30	0.40	0.60
Cast iron > 250 N/mm ²	10 - 20	0.05	0.15	0.25	0.35	0.55
CuZn alloy brittle	60 - 100	0.10	0.15	0.30	0.40	0.60
CuZn alloy ductile	35 - 60	0.05	0.10	0.25	0.35	0.55
Aluminum alloy up to 11% Si	30 - 50	0.10	0.20	0.30	0.40	0.60
Thermoplastics	20 - 40	0.05	0.10	0.20	0.30	0.40
Thermosetting materials with organic filling	15 - 35	0.05	0.10	0.20	0.30	0.40
Thermosetting materials with anorganic filling	15 - 25	0.05	0.10	0.20	0.30	0.40

5.2 Speed table

Vc in m/min	4	6	8	10	12	15	18	20	25	30	35	40	50	60	80	100
Drill bit Ø in mm	Speed n in rpm															
1,0	1274	1911	2548	3185	3822	4777	5732	6369	7962	9554	11146	12739	15924	19108	25478	31847
1,5	849	1274	1699	2123	2548	3185	3822	4246	5308	6369	7431	8493	10616	12739	16985	21231
2,0	637	955	1274	1592	1911	2389	2866	3185	3981	4777	5573	6369	7962	9554	12739	15924
2,5	510	764	1019	1274	1529	1911	2293	2548	3185	3822	4459	5096	6369	7643	10191	12739
3,0	425	637	849	1062	1274	1592	1911	2123	2654	3185	3715	4246	5308	6369	8493	10616
3,5	364	546	728	910	1092	1365	1638	1820	2275	2730	3185	3640	4550	5460	7279	9099
4,0	318	478	637	796	955	1194	1433	1592	1990	2389	2787	3185	3981	4777	6369	7962

Drilling_VC_qt_GB_basic.fm



Vc in m/ min	4	6	8	10	12	15	18	20	25	30	35	40	50	60	80	100
Drill bit Ø in mm	Speed n in rpm															
4,5	283	425	566	708	849	1062	1274	1415	1769	2123	2477	2831	3539	4246	5662	7077
5,0	255	382	510	637	764	955	1146	1274	1592	1911	2229	2548	3185	3822	5096	6369
5,5	232	347	463	579	695	869	1042	1158	1448	1737	2027	2316	2895	3474	4632	5790
6,0	212	318	425	531	637	796	955	1062	1327	1592	1858	2123	2654	3185	4246	5308
6,5	196	294	392	490	588	735	882	980	1225	1470	1715	1960	2450	2940	3920	4900
7,0	182	273	364	455	546	682	819	910	1137	1365	1592	1820	2275	2730	3640	4550
7,5	170	255	340	425	510	637	764	849	1062	1274	1486	1699	2123	2548	3397	4246
8,0	159	239	318	398	478	597	717	796	995	1194	1393	1592	1990	2389	3185	3981
8,5	150	225	300	375	450	562	674	749	937	1124	1311	1499	1873	2248	2997	3747
9,0	142	212	283	354	425	531	637	708	885	1062	1238	1415	1769	2123	2831	3539
9,5	134	201	268	335	402	503	603	670	838	1006	1173	1341	1676	2011	2682	3352
10,0	127	191	255	318	382	478	573	637	796	955	1115	1274	1592	1911	2548	3185
11,0	116	174	232	290	347	434	521	579	724	869	1013	1158	1448	1737	2316	2895
12,0	106	159	212	265	318	398	478	531	663	796	929	1062	1327	1592	2123	2654
13,0	98	147	196	245	294	367	441	490	612	735	857	980	1225	1470	1960	2450
14,0	91	136	182	227	273	341	409	455	569	682	796	910	1137	1365	1820	2275
15,0	85	127	170	212	255	318	382	425	531	637	743	849	1062	1274	1699	2123
16,0	80	119	159	199	239	299	358	398	498	597	697	796	995	1194	1592	1990

The correct manual feed Vc in meters per minute depends on the diameter of the drill, the material to be machined, the speed and the cutting material of the drill.



6 Maintenance

In this chapter you will find important information about

- Inspection,
- Maintenance and
- Repair.

ATTENTION!

Properly performed regular maintenance is an essential prerequisite for

- **operational safety,**
- **failure-free operation,**
- **long service life of the machine and**
- **the quality of the products which you manufacture.**

Installations and equipment from other manufacturers must also be in good order and condition.



ENVIRONMENTAL PROTECTION

During work on the spindle head, please make sure that

- **collecting containers with sufficient capacity for the amount of liquid to be collected are used.**
- **liquids and oils should not be split on the ground.**



Clean up any spilt liquid or oils immediately using proper oil-absorption methods and dispose of them in accordance with current legal requirements on the environment.

Collect leakages

Do not re-introduce liquids spilt outside the system during repair or as a result of leakage from the reserve tank; collect them in a collecting container for disposal.

Disposal

Never dump oil or other environmentally hazardous substances which are harmful to the environment in water inlets, rivers or channels.

Used oils must be delivered to a collection centre. Please consult your supervisor for further information on your nearest collection point.

6.1 Safety

WARNING!

The consequences of incorrect maintenance and repair work may include:

- **very serious injury to personnel working on the machine,**
- **damage to the machine.**

Only qualified personnel should carry out maintenance and repair work on the machine.



6.1.1 Preparation

WARNING!

Only work on the machine if it has been disconnected from the power supply.

Attach a warning sign which secures against unauthorized switching on.



6.1.2 Restarting

Before restarting, run a safety check.

👉 Safety check on page 10



WARNING!



Before starting the machine you must be sure that

- no dangers generated for persons,
- the machine is not damaged.

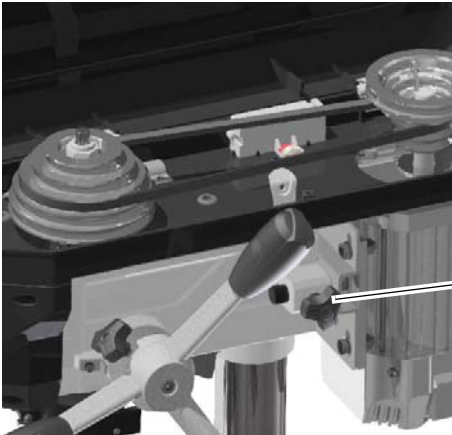

6.2 Inspection and maintenance

The type and level of wear depends to a large extent on the individual usage and operating conditions. Any indicated intervals therefore are only valid for the corresponding approved conditions.



Interval	Where?	What?	How?
Start of shift After each maintenance or repair work	Drilling machine	Examination for outside damages. ☞ Safety check on page 10	
weekly	Clamping bolts	Loosening	<ul style="list-style-type: none"> ➔ Check if the clamping screws for the V-belt tension on the left and right side of the drilling head are well fastened. ➔ Check if the V-belts are well tightened. Checking the tension of V-belts, ☞ Speed variation on page 27. 
Every month	Drill column and toothed rack	Oiling	<ul style="list-style-type: none"> ➔ Lubricate the drill column regularly with commercial oil. ➔ Lubricate the toothed rod regularly with commercial grease (e.g. friction bearing grease).  <p>Img.6-1: DQ22</p>

DQ14_DQ18_DQ22_GB_6.fm

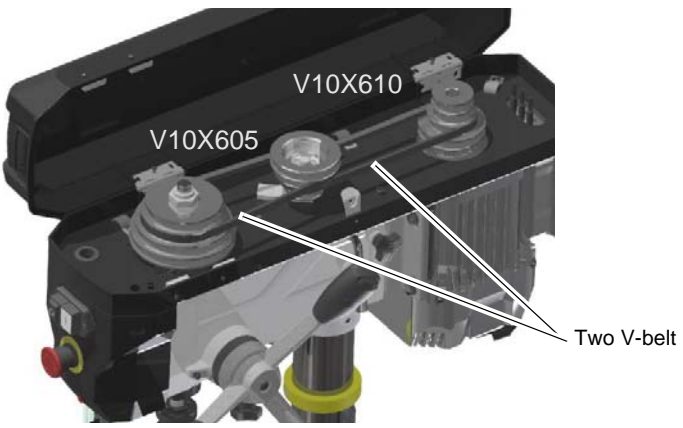

Interval	Where?	What?	How?
Every 6 months	V-belts at the drill head	Visual inspection	<p>→ Check whether the V-belts have become porous and worn.</p>  <p>XPZ 887</p> <p>One V-belt</p> <p>Img. 6-2: DQ14 DQ18</p>
Every 6 months	V-belts at the drill head	Visual inspection	<p>→ Check whether the V-belts have become porous and worn.</p>  <p>V10X610</p> <p>V10X605</p> <p>Two V-belt</p> <p>Img. 6-3: DQ22</p>

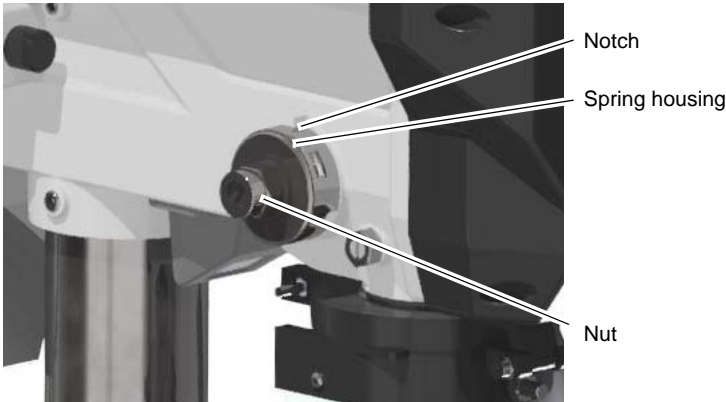

Interval	Where?	What?	How?
as required	Spindle return spring	Checking, replacing	<p>CAUTION!</p> <p> The spiral spring can unwind. Parts can fly towards you.</p> <ul style="list-style-type: none"> ➔ Loosen the nut. Under no circumstances remove the nut completely from the thread! ➔ Hold the spring housing with one hand, while using the other hand to slowly remove the housing. ➔ Rotate the spring housing about its own axis until the pin snaps into the next notch. ➔ If no resistance can be detected, the spring may be broken. <div style="text-align: right;">  </div> <div style="text-align: center;">  </div> <p>Img.6-4: Spindle return spring</p> <p>INFORMATION</p> <p> Ensure that the notch is always snapped into the spring housing properly and subsequently tighten the nut.</p>
Every month	Drilling column and Toothed rod	Oiling	<ul style="list-style-type: none"> ➔ Lubricate the drill column regularly with commercial oil, machine oil, engine oil. ➔ Lubricate the toothed rod regularly with commercial grease (e.g. friction bearing grease).
Every month	Oiler cup	Oiling	<ul style="list-style-type: none"> ➔ Lubricate all oiler cups (height adjustment drilling table) with machine oil, do not use grease guns or the like.

DQ14_DQ18_DQ22_GB_6.fm

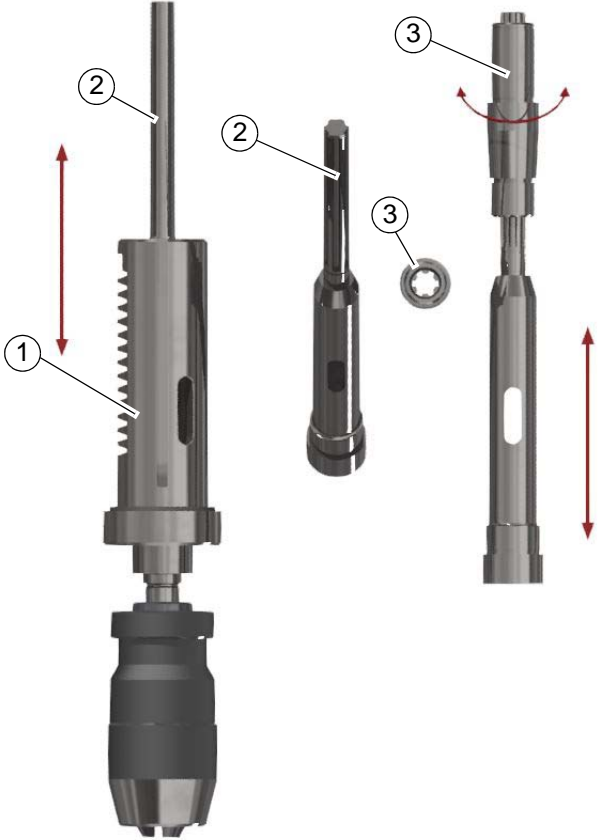

Interval	Where?	What?	How?
in case of need	Toothing of the spindle	Lubrication	<p>Any unusual rattling noises can be eliminated by regreasing. The sleeve (1) moves downwards or upwards with the toothed spindle (2) in the fixed driven sleeve (3) during drill feed. The noises are caused by the necessary clearance between the two toothings of the sleeve and spindle. The grease in the delivery condition may have been used up.</p>  <p>Img.6-5: Regreasing is carried out from above via the spindle drive. Apply grease at the visible toothed area of the spindle. It is recommended to use a grease which can remain permanently inside the toothings. The grease "Staburag NBU 30 PTM" from Klüber is recommended and has proved to be a successful assembly grease for clearance fits.</p>

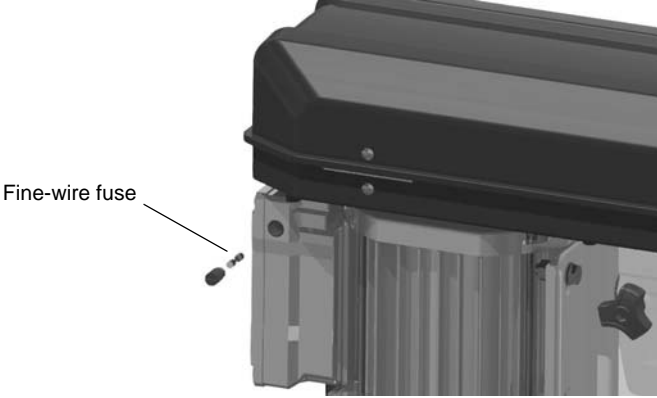

Interval	Where?	What?	How?
in case of need	Motor cover DQ22		<p>→ Replace fine-wire fuse. → If the fuse trips again, have the electrical system checked by a specialist.</p>  <p>Img.6-6: DQ22 - fine-wire fuse</p>
according to operator's historic values in accordance with German DGUV (BGV A3)	Electronics	Electrical inspection	<p>👉 Inspection deadlines on page 13 👉 Electronics on page 13</p>

INFORMATION

The spindle bearing is lifetime-lubricated. It is not necessary to lubricate it again.



6.3 Repair

6.3.1 Customer service technician

For any repair work request the assistance of an authorised customer service technician. Contact your specialist dealer if you do not have customer service's information or contact Stürmer Maschinen GmbH in Germany who can provide you with a specialist dealer's contact information. Optionally, the

Stürmer Maschinen GmbH
 Dr.-Robert-Pfleger-Str. 26
 D- 96103 Hallstadt

can provide a customer service technician, however, the request for a customer service technician can only be made via your specialist dealer. If repairs are carried out by qualified technical personnel, they must follow the indications given in these operating instructions.

Optimum Maschinen Germany GmbH accepts no liability nor does it guarantee against damage and operating malfunctions resulting from failure to observe these operating instructions.

For repairs, only use

- faultless and suitable tools,
- original parts or parts from series expressly authorised by Optimum Maschinen Germany GmbH.

DQ14_DQ18_DQ22_GB_6.fm

7 Ersatzteile - Spare parts

7.1 Ersatzteilbestellung - Ordering spare parts

Bitte geben Sie folgendes an - Please indicate the following :

- Seriennummer - *Serial No.*
- Maschinenbezeichnung - *Machines name*
- Herstellungsdatum - *Date of manufacture*
- Artikelnummer - *Article no.*

Die Artikelnummer befindet sich in der Ersatzteilliste. *The article no. is located in the spare parts list.* Die Seriennummer befindet sich am Typschild. *The serial no. is on the rating plate.*

7.2 Hotline Ersatzteile - Spare parts Hotline



+49 (0) 951-96555 -118
ersatzteile@stuermer-maschinen.de



7.3 Service Hotline



+49 (0) 951-96555 -100
service@stuermer-maschinen.de



7.3.1 DQ14 - Bohrkopf - Drill head



Abb.7-1: DQ14 - Bohrkopf - Drill head

DQ14_DQ18_DQ22_parts.fm

DQ14 - Ersatzteilliste Bohrkopf - Spare part list drill head					
Pos.	Bezeichnung	Designation	Menge	Grösse	Artikelnummer
			Qty.	Size	Item no.
1	Zylinderstift	Cylindrical pin	1		03191040101
2	Rückholfeder	Return spring	1		03191040102
3	Gehäuse	Housing	1		03191040103
4	Riemenscheibe	Belt pulley	1		03191040104
5	Mitnehmer	Carrier	1		03191040105
6	Kugellager	Ball bearing	2	6203	0406203R
7	Gewindestift	Grub screw	2	M8X10	
8	Sechskantmutter	Hexagon nut	1	M8	
9	Gewindestift	Grub screw	1		03191040109
10	Motorscheibe	Motor pulley	1		03191040110
11	Keilriemen	V-belts	1	XPZ 887	03191040111
12	Pinole	Sleeve	1		03191040112
13	Bohrspindel	Drilling spindle	1		03191040113
14	Sicherungsring	Retaining ring	1	12	03191040114
16	Kugellager	Ball bearing	2	6201	0406201R
17	Welle	Shaft	1		03191040117
18	Vorschubgrif	Feed grif	1		03191040118
19	Skalenring	Scale ring	1		03191040119
20	Klemmschraube	Clamping screw	1		03191040120
21	Klemmschraube	Clamping screw	1		03191040121
22	Ring	Ring	1		03191040122
23	Buchse	Bushing	1		03191040123
24	Scheibe	Washer	1		03191040124
25	Sprengring	Retaining ring	1	6	
26	Schraube	Screw	2	M6x20	
29	Not-Halt-Schalter	Emergency stop	1	HY57B	03191040129
30	Lichtschalter	Light switch	1	KCD117	03191040130
32	Gehäuse	Housing	1		03191040132
33	Abdeckung	Cover	1		03191040133
37	Ein-Aus-Taster	On-Off button	1	FSZ-KJD17B AF1	03191040137
47	Futterschutz	Chuck protection	1		03191040147
48	Sechskantmutter	Hexagon nut	1	M4	
49	Schraube	Screw	1	M4X28	
51	Klemmmutter	Clamping nut	2	M5	
52	Schraube	Screw	2	M5X10	
55	Futterschutz	Chuck protection	1		03191040155
45 - 55	Bohrfutterschutz komplett	Drill chuck protection	1		0319104014555
56	Scheibe	Washer	2		03191040156
57	Feder	Spring	1		03191040157
58	Scheibe	Washer	1		03191040158
59	Scheibe	Washer	1		03191040159
60	Schraube	Screw	1		03191040160
61	Riemenabdeckung	Belt cover	1		03191040161
62	Riemenabdeckung	Belt cover	1		03191040162
63	Platte	Plate	1		03191040163
66	Dichtung	Seal	1		03191040166
68	Schraube	Screw	2		03191040168
71	Gehäuse	Housing	1		03191040171
72	Abdeckung	Cover	1		03191040172
73	Mikroschalter	Microswitch	1		03191040173
76	Klemmplatte	Clamping plate	1		03191040176
77	Dichtung	Seal	1		03191040177
78	Schraube	Screw	12		03191040178
79	Scharnier	Hinge	2		03191040179
80	Schraube	Screw	2	M6x12	
82	Sicherungsring	Retaining ring	2	40	
84	Sechskantschraube	Hexagon head screw	4	M8x20	
86	Scheibe	Washer	1		03191040186
87	Abdeckung	Cover	1		03191040187
88	Glasabdeckung	Glass cover	1		03191040188
90	Halter	Holder	1		03191040190
92	LED-Leuchte	LED light	1		03191040192
93	Halter	Holder	1		03191040193
99	Sicherungsring	Retaining ring	1	22	
100	Anzeige	Display	1		031910401100

DQ14_DQ18_DQ22_parts.fm

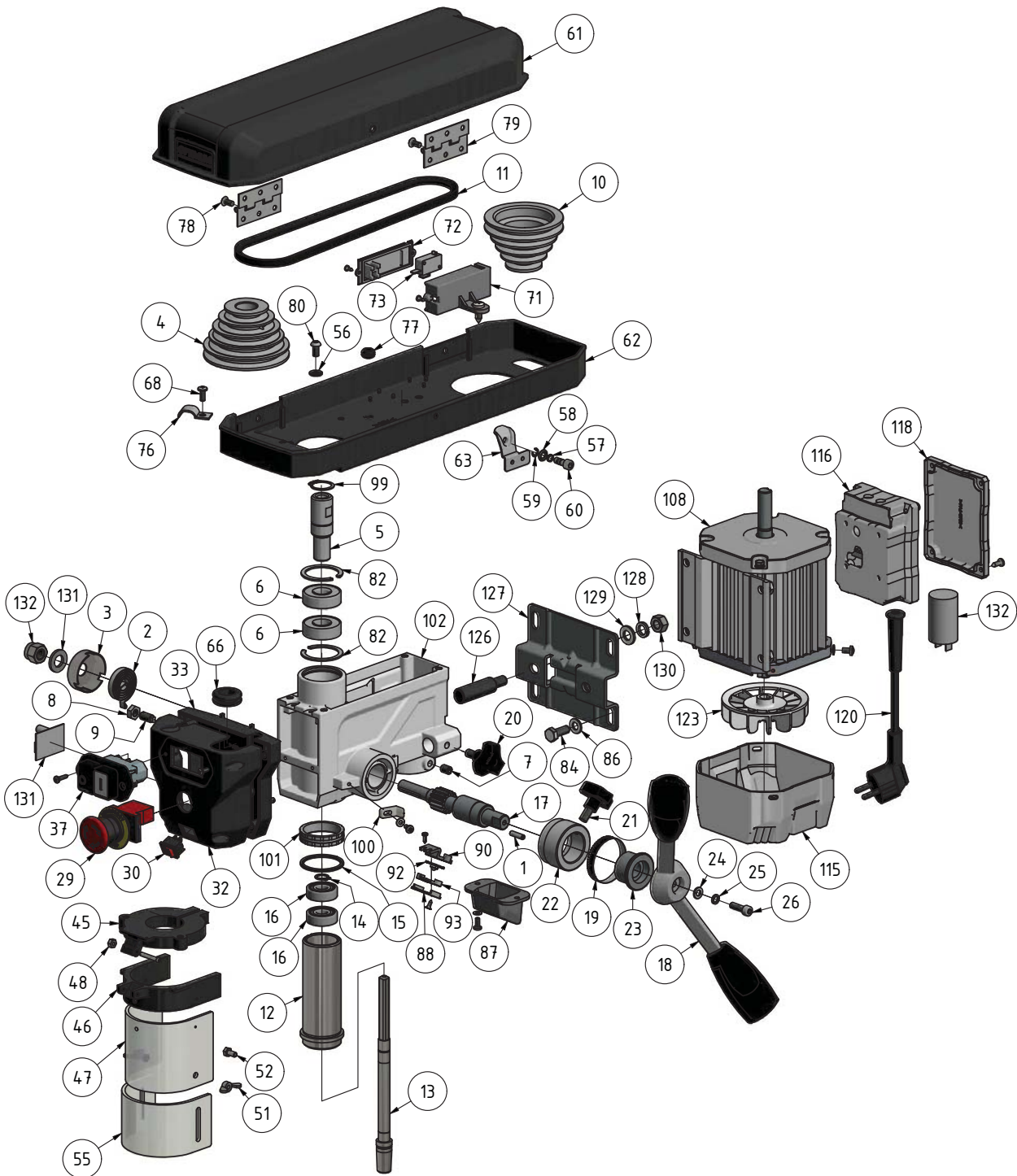
101	Ring	Ring	1		031910401101
102	Gehäuse	Housing	1		031910401102
108	Motor	Engine	1		031910401108
115	Abdeckung	Cover	1		031910401115
116	Gehäuse	Housing	1		031910401116
118	Abdeckung	Cover	1		031910401118
120	Netzstecker	Power plug	1	230V Steckdosen Typ F (Deutschland)	
123	Lüfter	Fan	1		031910401123
126	Bolzen	Bolt	1		031910401126
127	Motorplatte	Motor plate	1		031910401127
128	Sprengring	Retaining ring	4	10	
129	Scheibe	Washer	4	10	
130	Sechskantmutter	Hexagon nut	4	M10	
131	LED Trafo	LED transformer	1		031910401131
132	Anlauf Kondensator	Starting capacitor	1	CBB60B - 8 µF ± 5%	031910401132

7.3.2 DQ14 - Säule - Column



Abb.7-2: DQ14 - Säule - Column

DQ14 - Ersatzteilliste Säule- Spare part list column					
Pos.	Bezeichnung	Designation	Menge Qty.	Grösse Size	Artikelnummer Item no.
1	Säule	Column	1		
2	Skalenring	Scale ring	1		03191040201
3	Spannbolzen	Clamping bolt	1		03191040202
4	Spannhebel	Clamping lever	1		03191040203
5	Schraube	Screw	1	M12x25	
6	Scheibe	Washer	1	12	
7	Schraube	Screw	1		03191040206
8	Bohr Tisch	Drilling table	1		03191040207
9	Träger	Supporters	1		03191040208
10	Maschinenfuss	Machine Foot	1		03191040209
11	Schraube	Screw	3	M8x18	
12	Scheibe	Washer	3	8	
13	Federscheibe	Spring washer	3	8	

7.4 DQ14 - Schaltplan - Wiring diagram

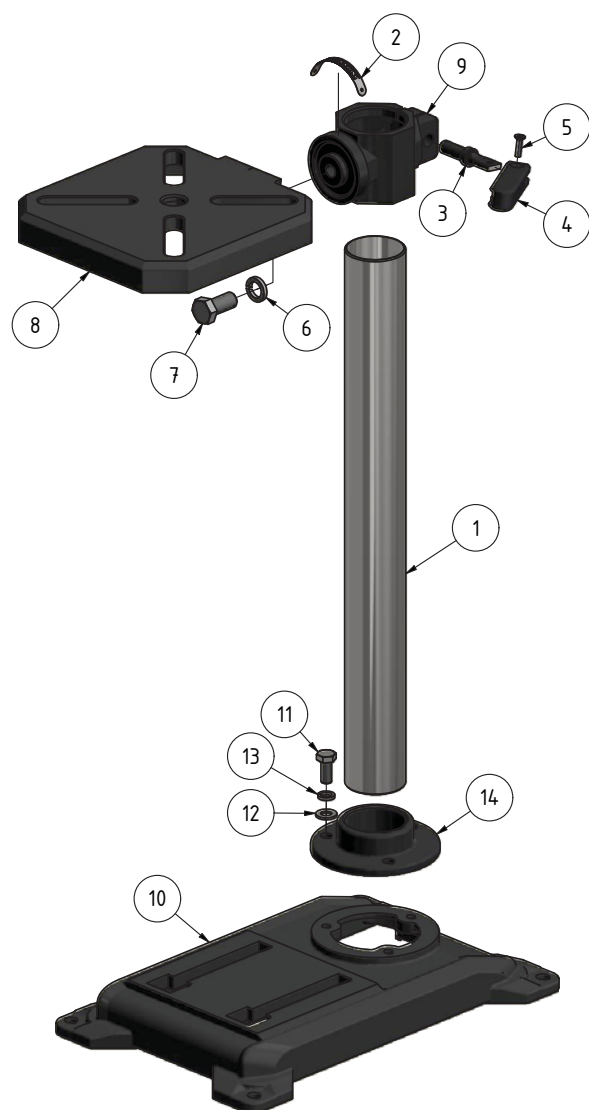
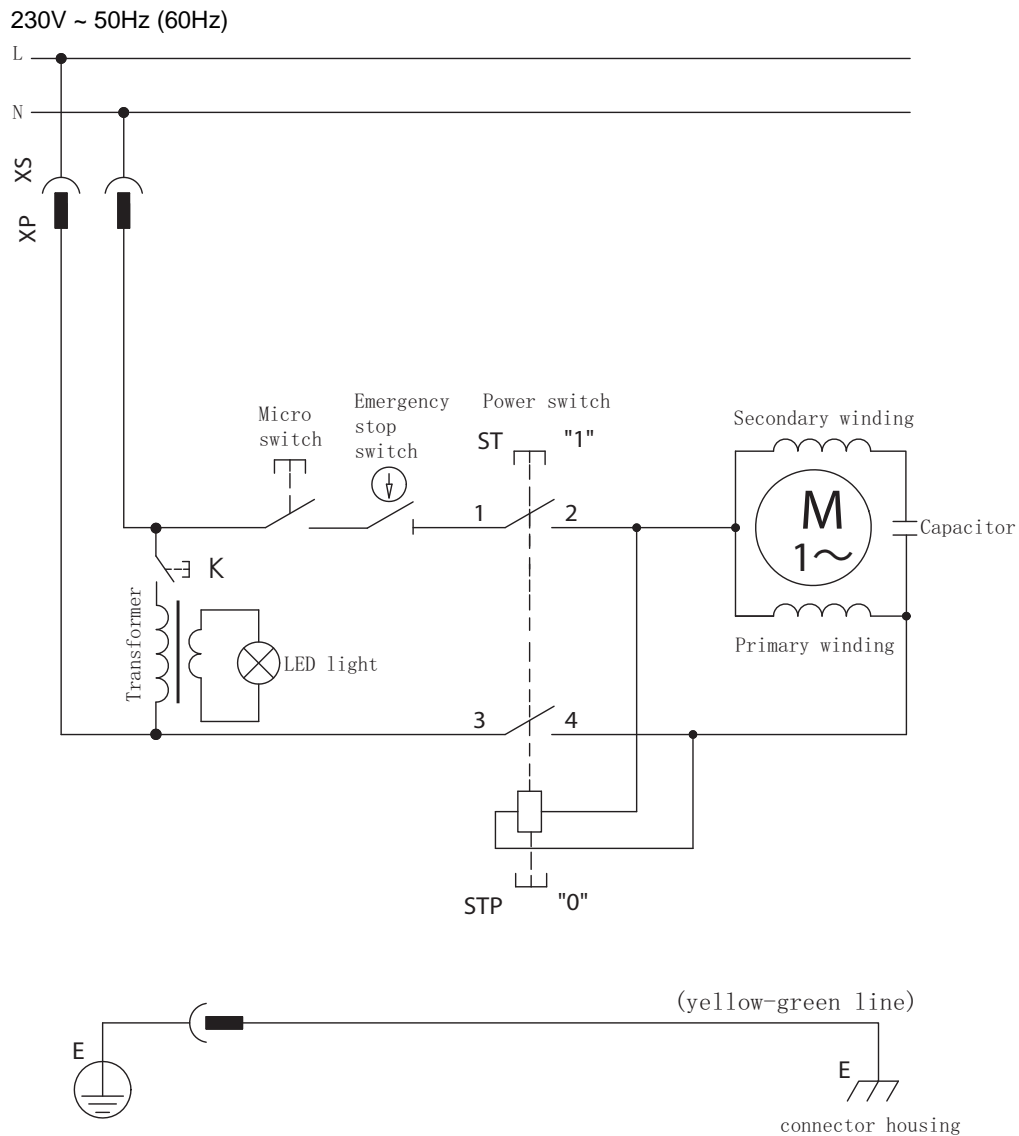

DQ14_DQ18_DQ22_parts.fm

7.4.1 DQ18 - Bohrkopf - Drill head



Abb.7-3: DQ18 - Bohrkopf - Drill head

DQ14_DQ18_DQ22_parts.fm

DQ18 - Ersatzteilliste Bohrkopf - Drill head spare part list					
Pos.	Bezeichnung	Designation	Menge	Grösse	Artikelnummer
			Qty.	Size	Item no.
1	Ring	Ring	1		03191042101
2	Klemmmutter	Clamping nut	1		03191042102
3	Gehäuse	Housing	1		03191042103
4	Riemenabdeckung	Belt cover	1		03191042104
5	Riemenabdeckung	Belt cover	1		03191042105
6	Scharnier	Hinge	2		03191042106
9	Schraube	Screw	1		03191042109
10	Feder	Spring	1		03191042110
11	Scheibe	Washer	2		03191042111
12	Scheibe	Washer	2	5	
13	Abdeckung	Cover	1		03191042113
14	Gehäuse	Housing	1		03191042114
16	Not-Halt-Schalter	Emergency stop switch	1	HY57B	03191042116
17	Bolzen	Bolt	2		03191042117
18	Riemenscheibe	Belt pulley	1		03191042118
19	Mitnehmer	Carrier	1		03191042119
20	Klemmmutter	Clamping nut	1	M20	
21	Motorscheibe	Motor pulley	1		03191042121
22	Klemmschraube	Clamping screw	3		03191042122
24	Lampenabdeckung	Lamp cover	1		03191042124
25	Abdeckung	Cover	1		03191042125
27	Platte	Plate	1		03191042127
29	LED-Lampe	LED lamp	1		03191042129
30	Platte	Plate	1		03191042130
32	O-Ring	O-ring	1		03191042132
34	Bohrspindel	Drilling spindle	1		03191042134
35	Sicherungsring	Circlip	1	12	
36	Kugellager	Ball bearing	1	6201-2Z	0406201
37	Kugellager	Ball bearing	1	6005-2Z	0406005
38	Dorn	Arbor	1		03191042138
39	Bohrfutterschutz	Drill chuck protection	1		03191042139
42	Bohrfutterschutz	Drill chuck protection	1		03191042142
44	Schraube	Screw	1	M5x35	
45	Sechskantmutter	Hexagon nut	1	M5	
39-45	Bohrfutterschutz komplett	Drill chuck protection complete	1		0319104213945
49	Klemmmutter	Clamping nut	2		03191042149
52	Zylinderstift	Cylindrical pin	1		03191042152
53	Ring	Ring	1		03191042153
54	Vorschubgrif	Feed grif	1		03191042154
55	Anzeige	Display	1		03191042155
56	Zahnwelle	Toothed shaft	1		03191042156
57	Abdeckung	Cover	1		03191042157
58	Rückholfeder	Return spring	1		03191042158
59	Platte	Plate	1		03191042159
60	Buchse	Bushing	2		03191042160
62	Schraube	Screw	2	M5x10	
63	Scheibe	Washer	5	5	
64	Scheibe	Washer	2	5	
65	Scheibe	Washer	4	10	
66	Sechskantmutter	Hexagon nut	2	M10	
67	Scheibe	Washer	8		03191042167
70	Sechskantschraube	Hexagon head screw	4	M8x25	
72	Lichtschalter	Light switch	1	KCD117	03191042172
84	Klemmplatte	Clamping plate	4		03191042184
87	Motorplatte	Motor plate	1		03191042187
88	Buchse	Socket	1		03191042188
89	Schraube	Screw	1	M8x20	
90	Scheibe	Washer	1	12	
91	Sechskantmutter	Hexagon nut	1	M12	
93	Motor	Engine	1		03191042193
95	Lüfter	Fan	1		03191042195
100	Klemmkasten	Terminal box	1		031910421100

DQ14_DQ18_DQ22_parts.fm

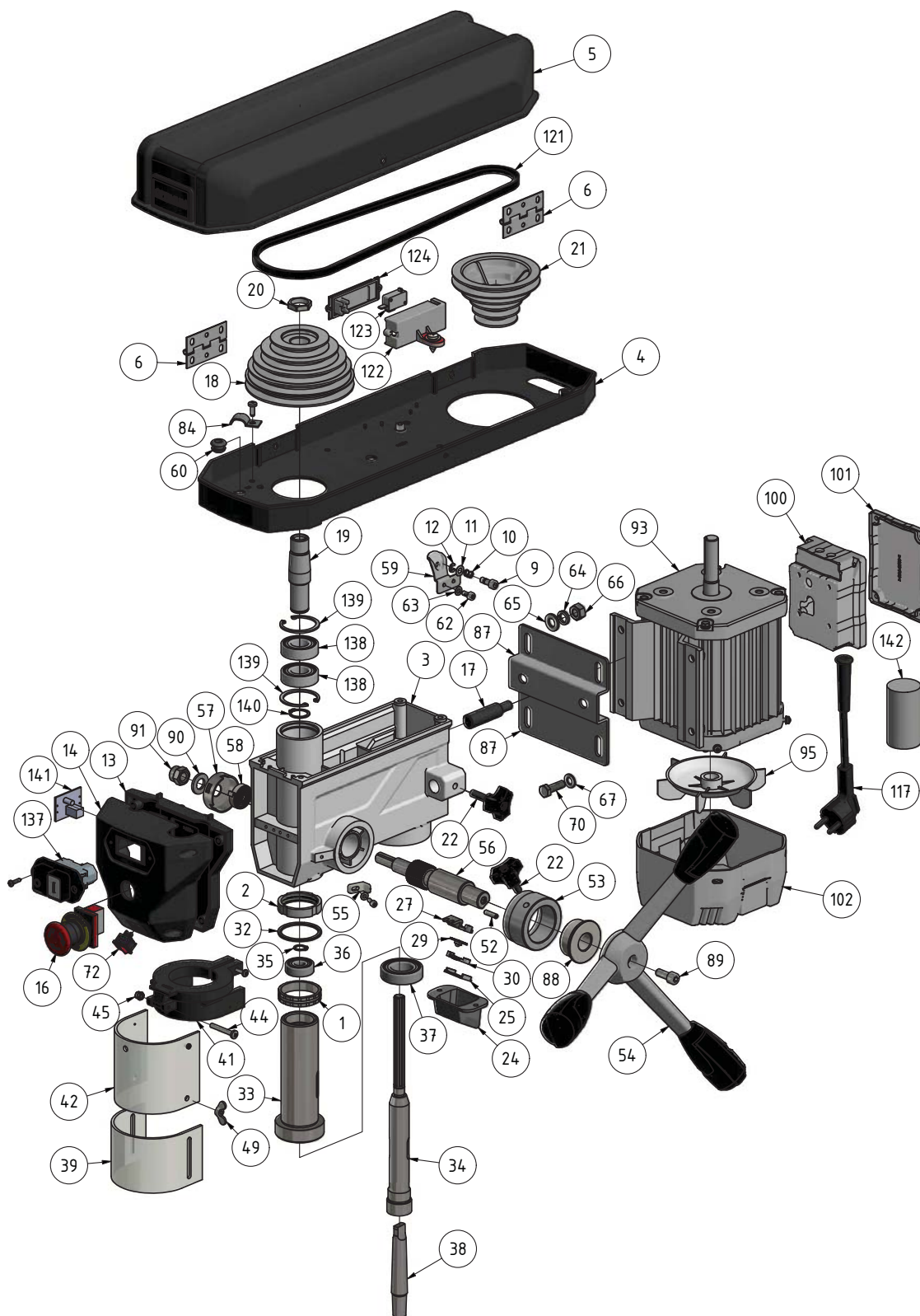
101	Abdeckung	Cover	1		031910421101
102	Motorabdeckung	Motor cover	1		031910421102
117	Netzstecker	Power plug	1	230V Steckdosen Typ F (Deutschland)	
121	Keilriemen	V-belts	1	XPZ 887	031910421121
122	Gehäuse	Housing	1		031910421122
123	Schalter	Switch	1	Y50-18	031910421123
124	Abdeckung	Cover	1		031910421124
137	Ein-Aus-Taster	On-Off button	1	DZ-KJD16_AF0	031910421137
138	Kugellager	Ball bearing	2	6004	0406004
139	Sicherungsring	Retaining ring	2	42 x 1,75	
140	Sicherungsring	Retaining ring	1	20x1,2	
141	LED Gleichrichter	LED rectifier	1		031910401131
142	Anlauf Kondensator	Starting capacitor	1	CBB60B - 10 µF ± 5%	031910421142

7.4.2 DQ18 - Säule - Column



Abb.7-4: DQ18 - Säule - Column

DQ14_DQ18_DQ22_parts.fm

DQ18 - Ersatzteilliste Säule - Column spare part list					
Pos.	Bezeichnung	Designation	Menge	Grösse	Artikelnummer
			Qty.	Size	Item no.
1		Machine Foot	1		03191042101
2	Säule	Column	1		03191042102
3	Halter	Holder	1		03191042103
4	Zahnstange	Rack	1		03191042104
5	Ring	Ring	1		03191042105
6	Gewindestift	Grub screw	1	M8x10	
7	Zahnrad	Gear wheel	1		03191042107
8	Schneckenwelle	Worm shaft	1		03191042108
9	Bolzen	Bolt	1		03191042109
10	Spanhebel	Clamping lever	1		03191042110
11	Schraube	Screw	1		03191042111
12	Hebel	Lever	1		03191042112
13	Handgriff	Handle	1		03191042113
14	Abdeckung	Cover	1		03191042114
15	Sechskantmutter	Hexagon nut	1	M8	
16	Schraube	Screw	1	M8x60	
17	Bohrtisch	Drilling table	1		03191042117
18	Federring	Spring washer	3	8	
19	Scheibe	Washer	3	8	03191042119
20	Bolzen	Bolt	1		03191042120
21	Schraube	Screw	3		03191042121
22	Flansch	Flange	1		03191042122
23	Skala	Scale	1		03191042123
24	Schraube	Screw	1	M10 x 30	
25	Scheibe	Washer	1	10	
26	Scheibe	Washer	1	M4 x 10	
27	Scheibe	Washer	1		03191042127
28	Gewindestift	Grub screw	1	M6 x 8	

DQ14_DQ18_DQ22_parts.fm

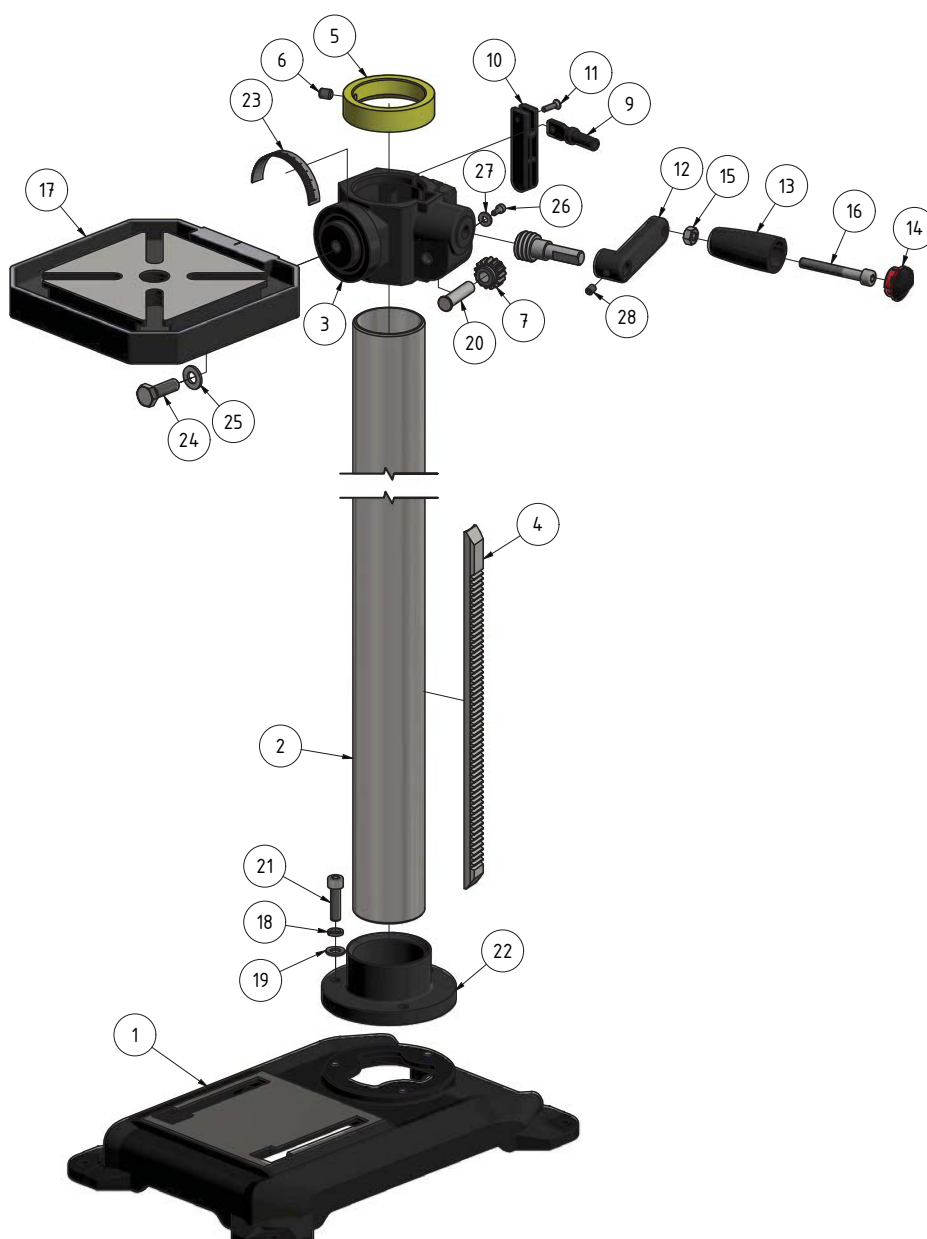
7.5 DQ18 - Schaltplan - Wiring diagram

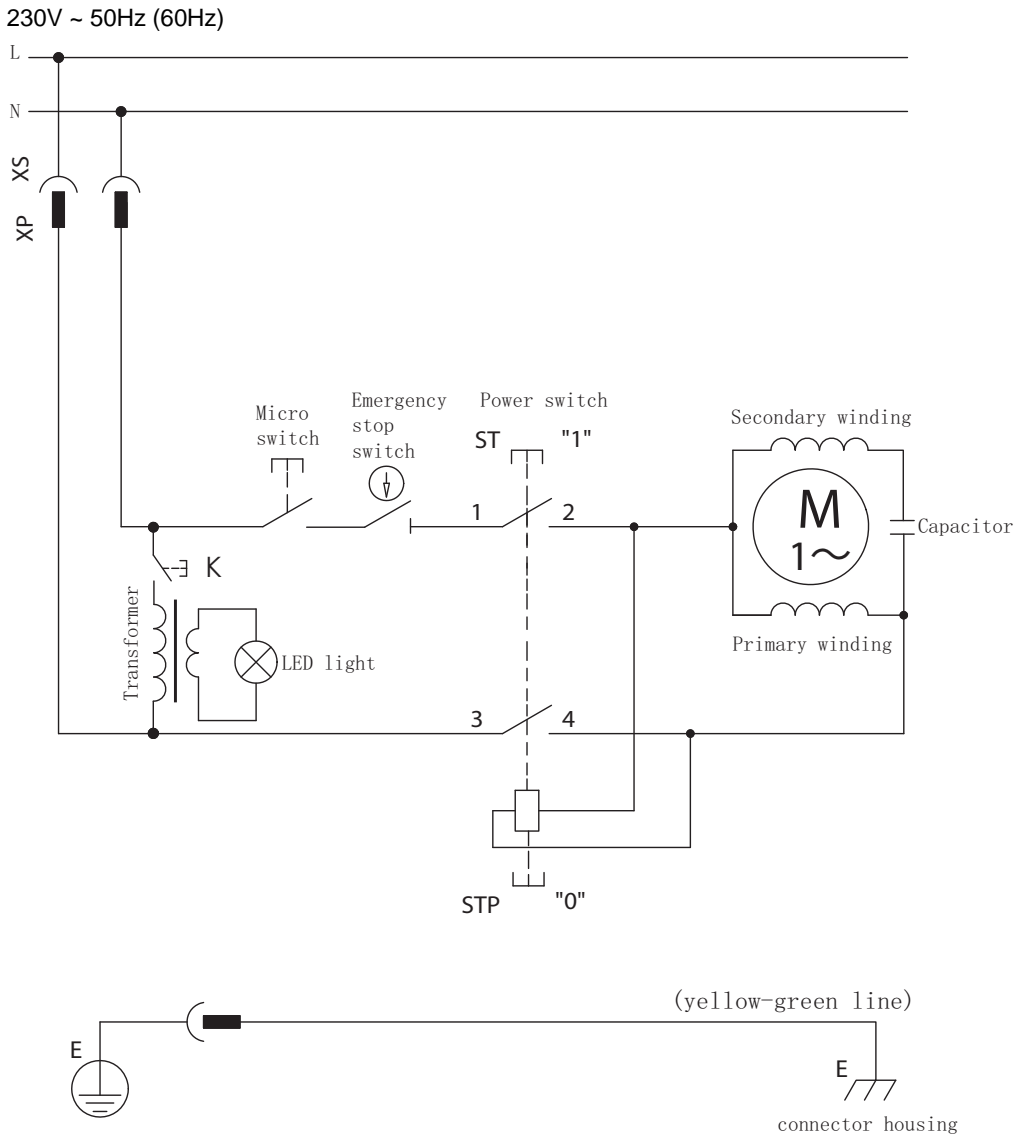

7.6 DQ22 - Bohrkopf - Drill head



Abb. 7-5: DQ22 - Bohrkopf - Drill head

DQ14_DQ18_DQ22_parts.fm

DQ22 - Ersatzteilliste Bohrkopf - Drill head spare part list					
Pos.	Bezeichnung	Designation	Menge	Grösse	Artikelnummer
			Qty.	Size	Item no.
1	Ring	Ring	1		03191044101
2	Ring	Ring	1		03191044102
3	Gehäuse	Housing	1		03191044103
4	Lampenabdeckung	Lamp cover	1		03191044104
7	Platte	Plate	1		03191044107
8	LED Lampe	LED light	1		03191044108
9	Platte	Plate	1		03191044109
11	Anzeige	Display	1		03191044111
17	Abdeckung	Cover	1		03191044117
18	Gehäuse	Housing	1		03191044118
20	Not-Halt-Schalter	Emergency stop switch	1		03191044120
22	Lichtschalter	Light switch	1	KCD117	03191044122
24	Motorplatte	Motor plate	1	230V motor only	03191044124
24				400V motor only	03191045124
25	Welle	Shaft	1		03191044125
26	Welle	Shaft	1		03191044126
27	Scheibe	Washer	5	12	
28	Federscheibe	Spring washer	2	12	
29	Sechskantmutter	Hexagon nut	2		03191044129
31	Klemmschraube	Clamping screw	2		03191044131
32	Spannhebel	Clamping lever	1		03191044132
34	Ring	Ring	1		03191044134
35	Mitnehmer	Carrier	1		03191044135
36	Kugellager	Ball bearing	3	6005-2Z	0406005
37	Riemenscheibe	Belt pulley	1		03191044137
38	Sechskantmutter	Hexagon nut	1		03191044138
40	Welle	Shaft	1		03191044140
42	Riemenscheibe	Belt pulley	1		03191044142
43	Sicherungsring	Circlip	1		03191044143
44	Kugellager	Ball bearing	2	6201-2Z	0406201
45	Motorscheibe	Motor pulley	1		03191044145
46	Ring	Ring	1		03191044146
48	Skalenring	Scale ring	1		03191044148
53	Sechskantmutter	Hexagon nut	5	M8	
54	Sechskantschraube	Hexagon head screw	4	M8x25	
55	Scheibe	Washer	8	8	
56	Gewindestift	Grub screw	2	M10x10	
58	Bohrspindel	Drilling spindle	1		03191044158
59	O-Ring	O-ring	1		03191044159
60	Sicherungsring	Retaining ring	1	15	
61	Kugellager	Ball bearing	1	6003-2Z	0406003R
62	Pinole	Sleeve	1		03191044162
63	Dorn	Arbor	1		03191044163
65	Vorschubgrif	Feed grif	1		03191044165
69	Welle	Shaft	1		03191044169
70	Platte	Plate	1		03191044170
72	Reedkontakt	Reed contact	2		03191044172
75	Buchse	Socket	1		03191044175
78	Gewindestift	Grub screw	1		03191044178
80	Klemmschraube	Clamping screw	1		03191044180
81	Buchse	Socket	1		03191044181
82	Schraube	Screw	1	M8x20	
83	ring	Ring	1		03191044183
86	Keilriemen	V-belt	1	V10X610 (motor v-belt)	0300620162
87	Keilriemen	V-belt	1	V10X605 (spindle v-belt)	0300820167
88	Platte	Plate	3		03191044188
104	Motor	Motor	1	230V motor	03191044104
104	Motor	Motor	1	400V motor	03191045104
118	Lüfter	Fan	1		03191044118
119	Anlaufkondensator	Startring capacitor	1	CD60 - 100 µF - DQ22-230V motor only	03191044119
120	Motordeckel	Engine cover	1	230V motor only	03191044120
120				400V motor only	03191045120
122	Klemmkasten	Terminal box	1	230V motor only	03191044122

DQ14_DQ18_DQ22_parts.fm

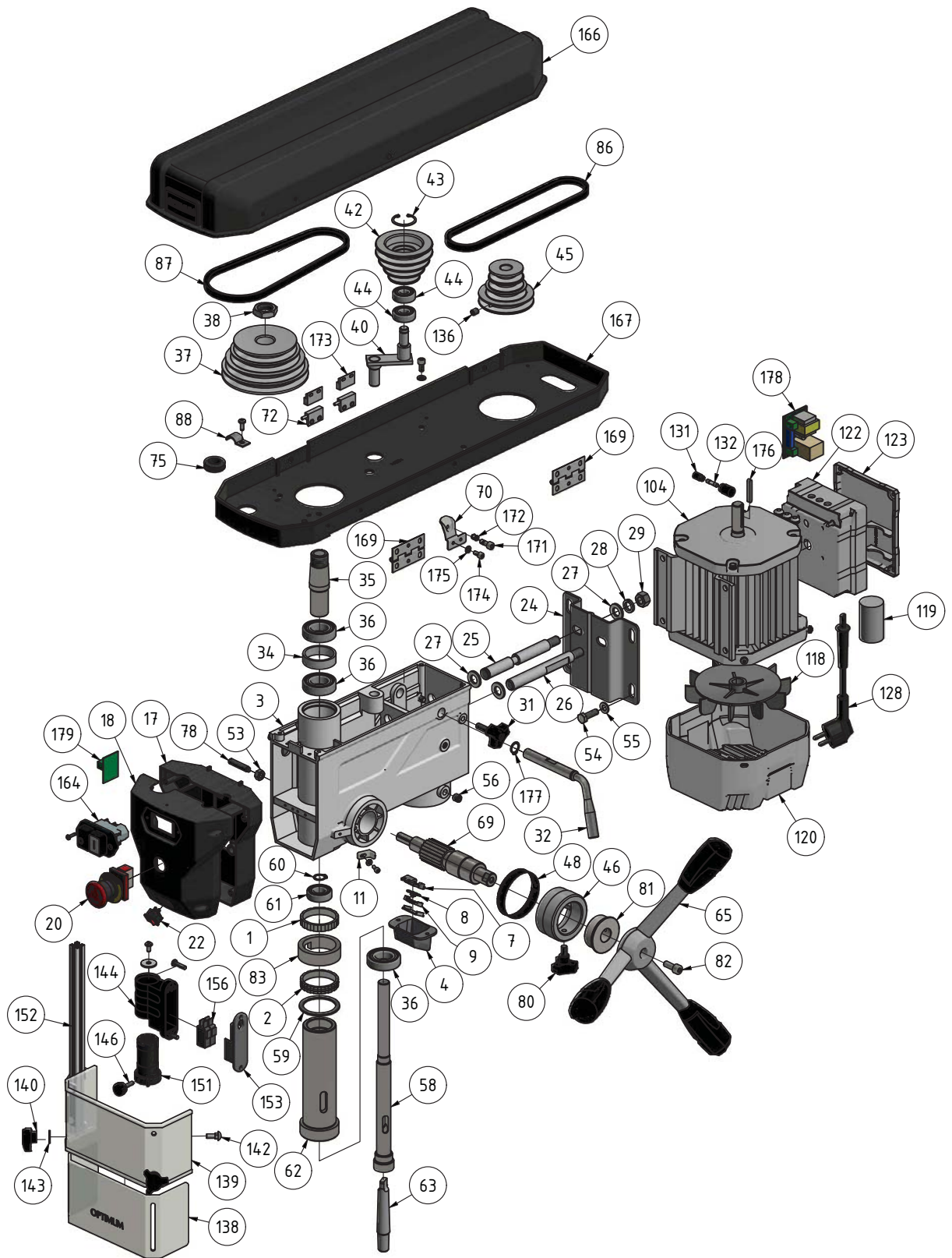
122	Klemmkasten	Terminal box	1	400V motor only	03191045122
123	Abdeckung	Cover	1	230V motor only	03191044123
123	Abdeckung	Cover	1	400V motor only	03191045123
128	Anschlusstecker	Connection plug	1	230V Steckdosen Typ F (Deutschland)	
128	Anschlusstecker	Connection plug	1	CEE three-phase plug	
131	Sicherungsgehäuse	Fuse box	1		03191044131
132	Feinsicherung träge	Fine-wire fuse slow	1	5A (DQ22 - 230V only)	
136	Gewindestift	Grub screw	1		03191044136
138	Bohrfutterschutz	Drill chuck protection	1		03191044138
139	Bohrfutterschutz	Drill chuck protection	1		03191044139
140	Klemmschraube	Clamping screw	2		03191044140
142	Scheibe	Disc	2	M6x16	
144	Halter	Holder	1		03191044144
146	Klemmschraube	Clamping screw	1	M5x20	
151	Buchse	Socket	1		03191044151
152	Stange	Rod	1		03191044152
153	Platte	Plate	1		03191044153
156	Mikroschalter	Microswitch	1		03191044156
164	Ein-Aus-Taster	On-Off button	1	DZ-KJD16_AF0 ; 230V only	03191044164
164	Ein-Aus-Taster	On-Off button	1	DQ22 - 400V only	03191045164
166	Riemenabdeckung	Belt cover	1		03191044166
167	Riemenabdeckung	Belt cover	1		03191044167
169	Scharnier	Hinge	2		03191044169
170	Niet	Rivet	4		03191044170
171	Schraube	Screw	1		03191044171
172	Feder	Spring	1		03191044172
173	Magnetischer Näherungsschalter	Magnetic proximity switch	2		03191044173
174	Schraube	Screw	1	M5x10	
175	Sechskantmutter	Hexagon nut	1	M5	
176	Passfeder	Feather key	1	5 x 5 x 36	
177	Sicherungsring	Retaining ring	1	14x1	
178	Steuerkarte	Control board	1	DQ22 - 230V only	03191044178
179	LED Gleichrichter	LED rectifier	1		031910401131
180	Drehrichtungsschalter	Rotary direction switch	1	without illustration, for DQ22-400V only	03191045180

7.6.1 DQ22 - Säule - Column



Abb.7-6: DQ22 - Säule - Column

DQ22 - Ersatzteilliste Säule - Column spare part list					
Pos.	Bezeichnung	Designation	Menge Qty.	Grösse Size	Artikelnummer Item no.
1	Träger	Supporters	1		03191045201
2	Führung	Guide	1		03191045202
3	Schneckenrad	Worm wheel	1		03191045203
4	Ring	Ring	1		03191045204
5	Zahnwelle	Toothed shaft	1		03191045205
6	Welle	Shaft	1		03191045206
7	Bohrfuss	Drill foot	1		03191045207
8	Flansch	Flange	1		03191045208
9	Säule	Column	1		03191045209
10	Zahnstange	Rack	1		03191045210
11	Skala	Scale	1		03191045211
12	Hebel	Lever	1		03191045212
13	Handhebel	Hand lever	1		03191045213
14	Abdeckung	Cover	1		03191045214
15	Sechskantmutter	Hexagon nut	1	M8	
16	Schraube	Screw	1	M8x60	

DQ14_DQ18_DQ22_parts.fm

17	Bolzen	Bolt	2		03191045217
18	Klemmhebel	Clamping lever	2		03191045218
19	Schraube	Screw	2	M4x16	
20	Anzeige	Display	2		03191045220
22	Schraube	Screw	2	M5x12	
23	Scheibe	Washer	2	5	
24	Gewindestift	Grub screw	1	M6x10	
25	Gewindestift	Grub screw	1	M8x10	
26	Bohrtisch	Drilling table	1		03191045226
28	Scheibe	Washer	5	10	
29	Schraube	Screw	5		03191045229
30	Schraube	Screw	5	M10x35	

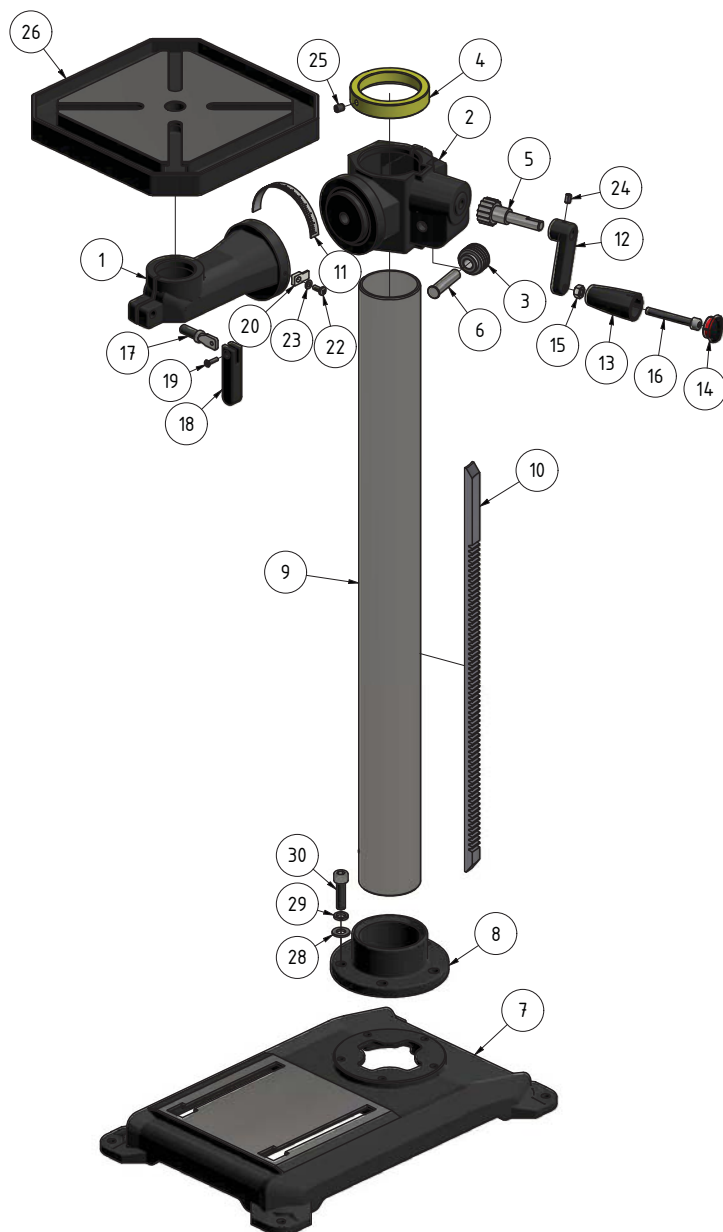
7.7 DQ22 - Schaltplan - Wiring diagram - 230V

230V ~ 50Hz (60Hz)

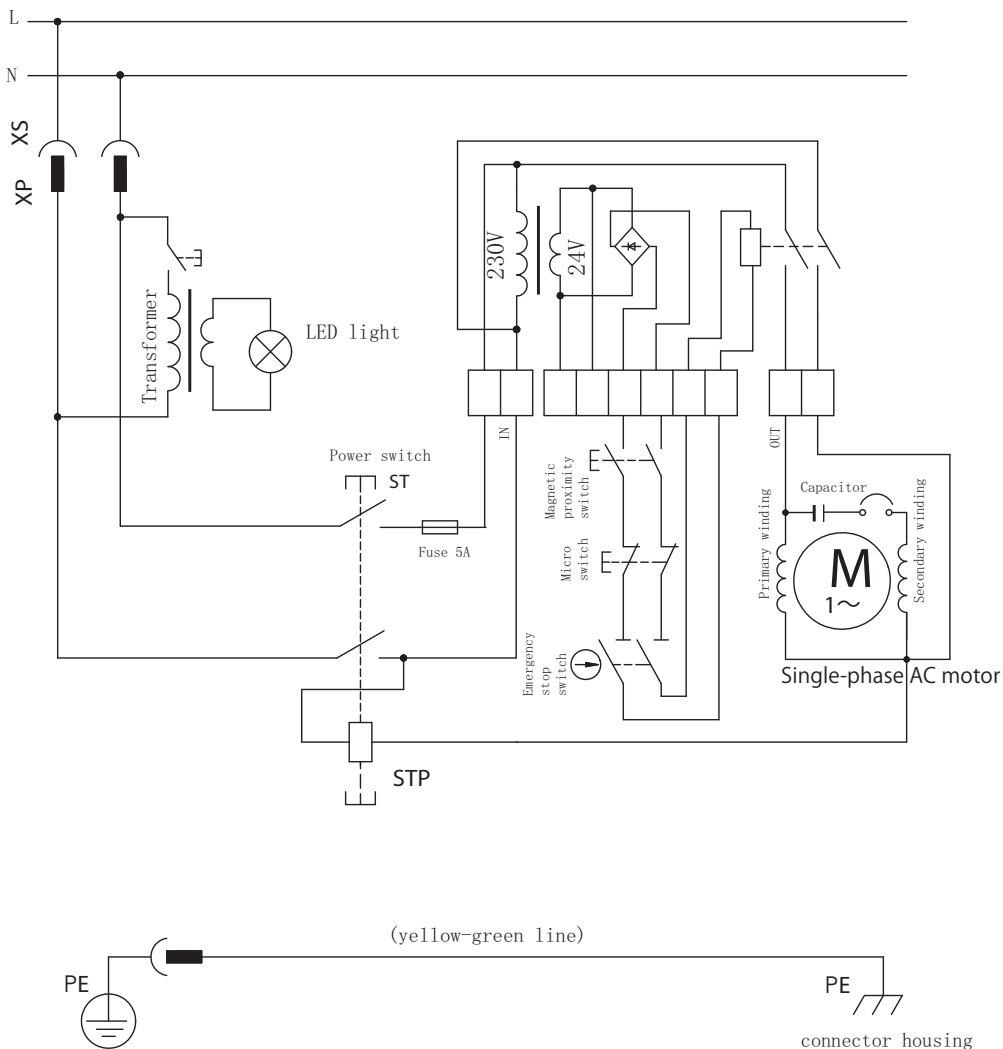

DQ14_DQ18_DQ22_parts.fm

7.8 DQ22 - Schaltplan - Wiring diagram - 400V

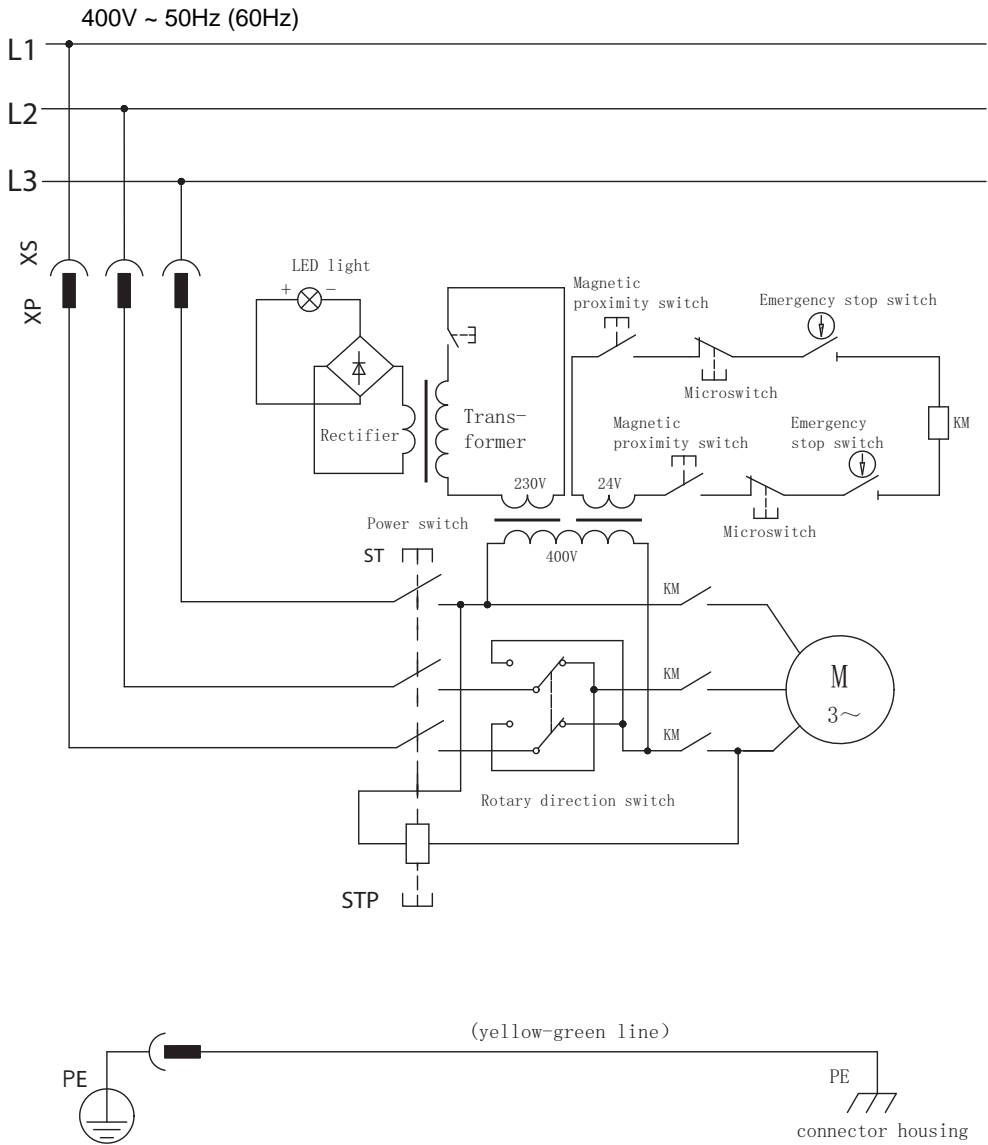



8 Malfunctions

Malfunction	Cause/ possible effects	Solution
Noise during work.	<ul style="list-style-type: none"> • Tool blunt or incorrectly clamped. • Grease at the tothing of the spindle used up • Spindle bearing defective • Bearing in idler pulley V-belt at DQ22 defective 	<ul style="list-style-type: none"> • Use new tool and check tension (fixed setting of the bit, drill chuck and taper mandril) • Put grease in, Tothing of the spindle on page 37 • Have permanently lubricated spindle bearings replaced by qualified personnel.
Bit „burnt“	<ul style="list-style-type: none"> • Incorrect speed • Chips are not coming out of the drilled hole. • Blunt drill bit. • Operating without cooling agent. 	<ul style="list-style-type: none"> • Choose a different speed, excessive feed. • Retract the drill bit from the bore hole more often. • Sharpen the drill bit or insert new drill bit. • Use coolant.
Drill point runs off, drilled hole is not circular.	<ul style="list-style-type: none"> • Hard material or length of the cutting spirals/or angles on the tool are unequal • Drill bit is bent. 	<ul style="list-style-type: none"> • Use a new drill bit.
Drill is running non-round or shaking	<ul style="list-style-type: none"> • Drill bit is bent. • Drill is not correctly clamped. • Drill chuck defective 	<ul style="list-style-type: none"> • Replace drill bit • Clamp the drill bit properly. • Replace the drill bit chuck.
The drill chuck or the Morse taper MT2 / B16 cannot be inserted or does not hold in the taper by itself.	<ul style="list-style-type: none"> • Dirt, grease or oil on the taper inside of the drill chuck or on the taper surface of the drill spindle 	<ul style="list-style-type: none"> • Clean surfaces well. • Keep surfaces free from grease.
Motor does not start.	<ul style="list-style-type: none"> • On DQ22, drill chuck protection not closed • Protective cover V-belt not closed • Defective control fuse (microfuse) on DQ22 	<ul style="list-style-type: none"> • Close drill chuck guard at DQ22 • Close protective cover of V-belt • Check control fuse on DQ22 and replace if necessary (DQ14 and DQ18 have no control fuse) „Img.6-6: DQ22 - fine-wire fuse“ on page 38
Motor runs only if the push button "On" is pressed permanently.	<ul style="list-style-type: none"> • Relay restart protection defective. 	<ul style="list-style-type: none"> • Have On / Off switch KJD17B replaced by qualified personnel.
Motor overheated and no power	<ul style="list-style-type: none"> • Motor overloaded? • Too low mains voltage • Motor incorrectly connected (DQ22 400V three-phase current) 	<ul style="list-style-type: none"> • Switch off immediately and have it checked by qualified personnel
Precision of the work deficient	<ul style="list-style-type: none"> • Heavy and unbalanced or deformed work-piece. • Inexact horizontal position of the work-piece holder. 	<ul style="list-style-type: none"> • Balance the piece statically and secure without straining • Adjust workpiece-holder
Drilling spindle sleeve does not return to its initial position	<ul style="list-style-type: none"> • Spindle return spring 	<ul style="list-style-type: none"> • „Img.6-4: Spindle return spring“ on page 36

DQ14_DQ18_DQ22_GB_8.fm



9 Appendix

9.1 Copyright

This document is protected by copyright. All derived rights are reserved, especially those of translation, re-printing, use of figures, broadcast, reproduction by photo-mechanical or similar means and recording in data processing systems, either partial or total.

Subject to technical changes without notice.

9.2 Terminology/Glossary

Term	Explanation
Drill drift	Tool to release the bit or the drill chuck from the drill spindle
Drill chuck	Drill bit adapter
Drill head	Upper part of the drilling machine
Drill sleeve	Fixed hollow shaft which runs in the drill spindle.
Drilling spindle	Shaft activated by the motor
Drilling table	Supporting surface, clamping surface
Taper mandrel	Cone of the drill or of the drill chuck
Spindle sleeve lever	Manual operation for the drill feed
Quick-action drill chuck	Drill holding fixture to be clamped manually.
Workpiece	Part to be drilled, part to be machined.
Tool	Drill bit, countersink, etc.

9.3 Liability claims/warranty

Besides the legal liability claims for defects of the customer towards the seller, the manufacturer of the product, OPTIMUM GmbH, Robert-Pfleger-Straße 26, D-96103 Hallstadt, does not grant any further warranties unless they are listed below or were promised as part of a single contractual provision.

- Liability or warranty claims are processed at OPTIMUM GmbH's discretion either directly or through one of its dealers.
Any defective products or components of such products will either be repaired or replaced by components which are free from defects. Ownership of replaced products or components is transferred to OPTIMUM Maschinen Germany GmbH.
- The automatically generated original proof of purchase which shows the date of purchase, the type of machine and the serial number, if applicable, is the precondition in order to assert liability or warranty claims. If the original proof of purchase is not presented, we are not able to perform any services.
- Defects resulting from the following circumstances are excluded from liability and warranty claims:
 - Using the product beyond the technical options and proper use, in particular due to overstraining of the machine.
 - Any defects arising by one's own fault due to faulty operations or if the operating manual is disregarded.
 - Inattentive or incorrect handling and use of improper equipment
 - Unauthorized modifications and repairs
 - Insufficient installation and safeguarding of the machine
 - Disregarding the installation requirements and conditions of use
 - atmospheric discharges, overvoltage and lightning strokes as well as chemical influences

DQ14_DQ18_DQ22_GB_9.fm



- The following items are also not subject to liability or warranty claims:
 - Wearing parts and components which are subject to normal and intended wear, such as V-belts, ball bearings, lighting, filters, seals, etc.
 - Non reproducible software errors
- Any services, which OPTIMUM GmbH or one of its agents performs in order to fulfil any additional warranty are neither an acceptance of the defects nor an acceptance of its obligation to compensate. Such services neither delay nor interrupt the warranty period.
- The court of jurisdiction for businessmen is Bamberg.
- If any of the aforementioned agreements is totally or partially inoperative and/or invalid, a provision which nearest approaches the intent of the guarantor and remains within the framework of the limits of liability and warranty which are specified by this contract is deemed agreed.

9.4 Storage

ATTENTION!

Incorrect and improper storage might result in damage or destruction of electrical and mechanical machine components.



Store packed and unpacked parts only under the intended environmental conditions.

Follow the instructions and information on the transport box.

- Fragile goods (Goods require careful handling)
- Protect against moisture and humid environment
- Prescribed position of the packing case (Marking of the top surface - arrows pointing to the top)
- Maximum stacking height
Example: not stackable - do not stack further packing case on top of the first one.



Consult Optimum Maschinen Germany GmbH if the machine and accessories are stored for more than three months or are stored under different environmental conditions than those specified here.

9.5 Advice for disposal / Options of reuse:

Please dispose of your equipment in an environmentally friendly manner, by not placing waste in the environment but in a professional manner.

Please do not simply throw away the packaging and later the disused machine, but dispose of both in accordance with the guidelines laid down by your city council/local authority or by an authorised disposal company.

DQ14_DQ18_DQ22_GB_9.fm



9.5.1 Decommissioning

CAUTION!

Used devices need to be decommissioned in a professional way in order to avoid later misuses and endangerment of the environment or persons.



- **Unplug the power cord.**
- **Cut the connection cable.**
- **Remove all operating materials from the used device which are harmful to the environment.**
- **If applicable remove batteries and accumulators.**
- **Disassemble the machine if required into easy-to-handle and reusable assemblies and component parts.**
- **Dispose of machine components and operating fluids using the intended disposal methods.**

9.5.2 Disposal of new device packaging

All used packaging materials and packaging aids from the machine are recyclable and generally need to be supplied to the material reuse.

The packaging wood can be supplied to the disposal or the reuse.

Any packaging components made of cardboard box can be chopped up and supplied to the waste paper collection.

The films are made of polyethylene (PE) and the cushion parts are made of polystyrene (PS). These materials can be reused after reconditioning if they are passed to a collection station or to the appropriate waste management enterprise.

Only forward the packaging materials correctly sorted to allow direct reuse.

9.5.3 Disposal of the old device

INFORMATION

Please take care in your interest and in the interest of the environment that all component parts of the machine are only disposed of in the intended and admitted way.

Please note that the electrical devices comprise a variety of reusable materials as well as environmentally hazardous components. Please ensure that these components are disposed of separately and professionally. If in doubt, consult your municipal waste disposal company. If appropriate, call on the help of a specialist waste disposal company for the treatment of the material.



9.5.4 Disposal of electrical and electronic components

Please make sure that the electrical components are disposed of professionally and according to the statutory provisions.

The machine contains electrical and electronic components and must not be disposed of as household waste. According to the European Directive regarding electrical and electronic used devices and the implementation of national legislation, used power tools and electrical machines need to be collected separately and supplied to an environmentally friendly recycling centre.

As the machine operator, you should obtain information regarding the authorised collection or disposal system which applies for your company.

Please make sure that the electrical components are disposed of professionally and according to the legal regulations. Please only throw depleted batteries in the collection boxes in shops or at municipal waste management companies.



9.6 Disposal via municipal collection facilities

Disposal of used electrical and electronic components
(Applicable in the countries of the European Union and other European countries with a separate collecting system for those devices).



The sign on the product or on its packing indicates that the product must not be handled as common household waste, but that it needs to be disposed of at a central collection point for recycling. Your contribution to the correct disposal of this product will protect the environment and the public health. Incorrect disposal constitutes a risk to the environment and public health. Material recycling will help reduce the consumption of raw materials. For further information about the recycling of this product, please consult your District Office, municipal waste collection station or the shop where you have purchased the product.

9.7 Change information operating manual

Chapter	Short summary	new version number
2 + 4 + Spare parts	DQ22 - 400V	1.0.1

9.8 Product follow-up

We are required to perform a follow-up service for our products which extends beyond shipment.

We would be grateful if you could send us the following information:

- Modified settings
- Any experiences with the geared drill which might be important for other users
- Recurring malfunctions

Optimum Maschinen Germany GmbH
Dr.-Robert-Pfleger-Str. 26
D-96103 Hallstadt
Fax +49 (0) 951 - 96 555 - 888
email: info@optimum-maschinen.de

9.9 Erwartete Genauigkeit - Expected accuracy

Der Abschlussbericht der Genauigkeit liegt der Maschine **nicht** bei. *The final accuracy report is **not** enclosed with the machine.*

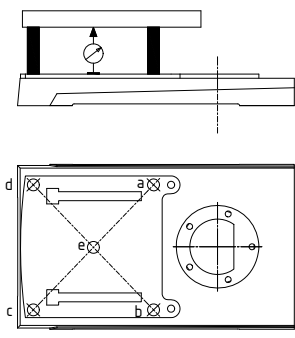
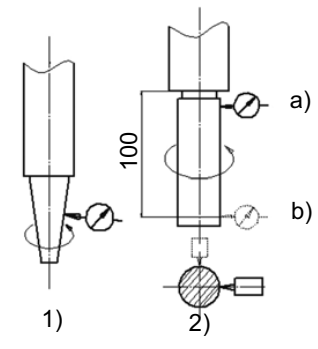
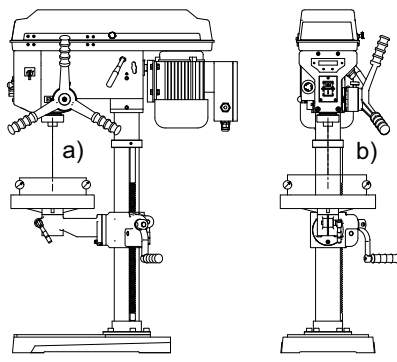
Nr. No.	Testobjekt Object of testing	Zeichnung Drawing	Toleranz Tolerance [mm]	Messwert Measured value [mm]
1	<p>Ebenheit der Arbeitsfläche der Grundplatte <i>Flatness of the working surface of the base</i></p>		0.3 / 300	
2	<p>Rundlauf der Spindelachse 1) Außenkegel 2) Innenkegel <i>Radial runout of spindle axis</i> 1) <i>Outer cone</i> 2) <i>Inner cone</i></p>		<p>1) 0.02 2a) 0.02 Nahe an der Stirnfläche der Spindel <i>Close to the front face of the spindle</i> 2b) 0.04 100 mm von der Stirnfläche der Spindel entfernt <i>100 mm from the front face of the spindle</i></p>	<p>1) 2a) 2b)</p>
3	<p>Rechtwinkligkeit der Spindeldrehachse zur Tischfläche <i>Perpendicularity of the spindle rotation axis to the table surface</i></p>		<p>a) 0.3 / 150 In der horizontalen Ebene <i>In the horizontal plane</i> b) 0.3 / 150 In der horizontalen Ebene <i>In the horizontal plane</i></p>	<p>a) b)</p>

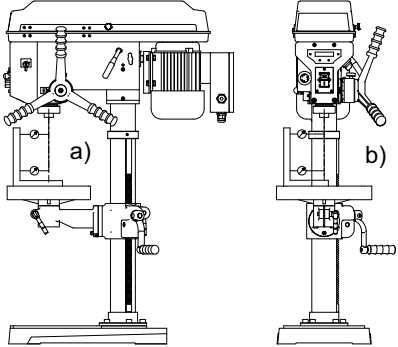
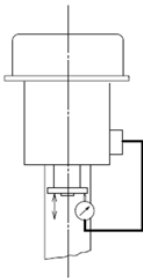
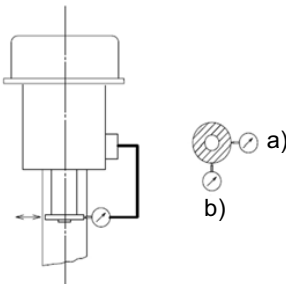
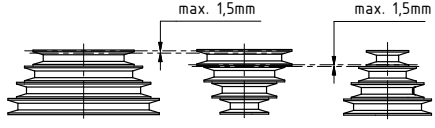
Nr. No.	Testobjekt Object of testing	Zeichnung Drawing	Toleranz Tolerance [mm]	Messwert Measured value [mm]
4	<p>Rechtwinkligkeit der Spindeldrehachse zur Tischfläche <i>Perpendicularity of the spindle rotation axis to the table surface</i></p>		<p>a) 0.3 / 200 In der vertikalen Ebene <i>In the vertical plane</i> b) 0.3 / 200 In der vertikalen Ebene <i>In the vertical plane</i></p>	<p>a) b)</p>
5	<p>Axiale Bewegung der Pinole <i>Axial movement of the spindle sleeve</i></p>		<p>0.2</p>	
6	<p>Radiale Bewegung der Pinole (bei vollem Hub) <i>Radial movement of the sleeve (at full stroke)</i></p>		<p>a) 0.25 b) 0.25</p>	<p>a) b)</p>
7	<p>maximale Höhendifferenz der Riemenscheiben <i>Maximum height difference of the pulleys</i></p>		<p>< 1.5 mm</p>	



EC Declaration of Conformity

according to Machinery Directive 2006/42/EC Annex II 1.A

The manufacturer / distributor Optimum Maschinen Germany GmbH
Dr.-Robert-Pfleger-Str. 26
D96103 Hallstadt

hereby declares that the following product

Product designation: Bench drill

Type designation: DQ 14 | DQ 18

fulfills all the relevant provisions of the directive specified above and the additionally applied directives (in the following) - including the changes which applied at the time of the declaration.

Description:

Hand-controlled drilling machine

The following other EU Directives have been applied:

EMC Directive 2014/30/EU ; Restriction of the use of certain hazardous substances in electrical and electronic equipment 2015/863/EU

The following harmonized standards were applied:

EN 61029-1+A11:2010-02-28 - Safety of transportable motor-operated electric tools. General requirements

EN 12717: 2001+A1:2009 Safety of machine tools - Drilling machines

EN 55014-1:2018-08; VDE 0875-14-1 - EN 55014-1:2018-08; VDE 0875-14-1 - Electromagnetic compatibility - Requirements for household appliances, electric tools and similar apparatus - Part 1: Emission

EN 55014-2:2016-01; VDE 0875-14-2:2016-01 - EN 55014-2:2016-01; VDE 0875-14-2:2016-01 - Electromagnetic compatibility - Requirements for household appliances, electric tools and similar apparatus - Part 2: Immunity

EN 61000-3-2:2015-03; VDE 0838-2:2015-03 - Electromagnetic compatibility (EMC) - Part 3-2: Limits - Limits for harmonic current emissions (equipment input current ≤ 16 A per phase)

EN 61000-3-3:2014-03; VDE 0838-3:2014-03 - Electromagnetic compatibility (EMC) - Part 3-3: Electromagnetic compatibility (EMC) - Part 3-3: Limits - Limitation of voltage changes, voltage fluctuations and flicker in public low-voltage supply systems, for equipment with rated current ≤ 16 A per phase and not subject to conditional connection

EN ISO 12100:2013 - Safety of machinery - General principles for design - Risk assessment and risk reduction

Name and address of the person authorized to compile the technical file:

Kilian Stürmer, phone: +49 (0) 951 96555 - 800

Kilian Stürmer (CEO, General Manager)
Hallstadt, 2020-06-29



EC Declaration of Conformity

according to Machinery Directive 2006/42/EC Annex II 1.A

The manufacturer / distributor Optimum Maschinen Germany GmbH
Dr.-Robert-Pfleger-Str. 26
D96103 Hallstadt

hereby declares that the following product

Product designation: Bench drill

Type designation: DQ 22

fulfills all the relevant provisions of the directive specified above and the additionally applied directives (in the following) - including the changes which applied at the time of the declaration.

Description:

Hand-controlled drilling machine

The following other EU Directives have been applied:

EMC Directive 2014/30/EU ; Restriction of the use of certain hazardous substances in electrical and electronic equipment 2015/863/EU

The following harmonized standards were applied:

EN 12717: 2001+A1:2009 Safety of machine tools - Drilling machines

EN 55014-1:2018-08; VDE 0875-14-1 - EN 55014-1:2018-08; VDE 0875-14-1 - Electromagnetic compatibility - Requirements for household appliances, electric tools and similar apparatus - Part 1: Emission

EN 55014-2:2016-01; VDE 0875-14-2:2016-01 - EN 55014-2:2016-01; VDE 0875-14-2:2016-01 - Electromagnetic compatibility - Requirements for household appliances, electric tools and similar apparatus - Part 2: Immunity

EN 61000-3-2:2015-03; VDE 0838-2:2015-03 - Electromagnetic compatibility (EMC) - Part 3-2: Limits - Limits for harmonic current emissions (equipment input current ≤ 16 A per phase)

EN 61000-3-3:2014-03; VDE 0838-3:2014-03 - Electromagnetic compatibility (EMC) - Part 3-3: Electromagnetic compatibility (EMC) - Part 3-3: Limits - Limitation of voltage changes, voltage fluctuations and flicker in public low-voltage supply systems, for equipment with rated current ≤ 16 A per phase and not subject to conditional connection

EN ISO 12100:2013 - Safety of machinery - General principles for design - Risk assessment and risk reduction

Name and address of the person authorized to compile the technical file:

Kilian Stürmer, phone: +49 (0) 951 96555 - 800

Kilian Stürmer (CEO, General Manager)
Hallstadt, 2020-06-29



Index

A	
Accident report	13
C	
Classification of hazards	5
Control and indicating elements	23
Control panel	24
Copyright	56
Customer service	38
Customer service technician	38
D	
Dimensions	
DQ14	16
DQ18	17
DQ22	18
Disposal	59
E	
EC - declaration of conformity	62, 63
Electrical connection	22
Electronics	13
F	
First commissioning	21
I	
Inspection	34
M	
Maintenance	33, 34
Malfunctions	55
O	
Obligations	
user	9
Operation	23
P	
Personal protective equipment	12
Pictograms	6
Product follow-up	59
Prohibition, warning and mandatory signs	12
S	
Safety	
During maintenance	12
During operation	12
Safety devices	9
Safety instructions	5
Service Hotline	39
Specialist dealer	38
T	
Table cutting speeds	31
Target group	
private users	9
Technical specification	14
Transport	19
W	
Warming up the machine	22
Warning notes	5