

# P160M110X

CONSTRUCTION VEHICLE SEATS 

HEADREST

ADJUSTABLE  
ARMREST

2PNT  
SEAT BELT

BACKREST  
ADJUSTMENT

WEIGHT  
ADJUSTMENT

FORE AND AFT  
ADJUSTMENT

HEIGHT  
ADJUSTMENT

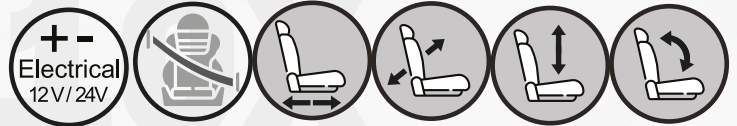

## P160M110X

Air suspension	▲
Air suspension with 12V or 24V built-in compressor	▲
Mechanical suspension	●
Weight adjustment	Manual up to 150kgs
Suspension stroke	80mm
Optional suspension stroke	60mm
Turn Table	▲
Slide travel	190mm
Lumbar adjustment	▲
Adjustable /foldable armrests	▲
Adjustable headrest	●
Backrest adjustment	●
Seat cushion tilt adjustment	N/A
Seat cushion depth adjustment	N/A
Vinyl trim (cut & sew)	N/A
Cloth trim (cut & sew)	▲ Order P165 CEA150D
Vinyl trim (Vacuum type)	●
Cloth trim (Vacuum type)	▲
Genuine leather trim	N/A
3-point seat belt	N/A
2-point seat belt	▲
Document box-pouch	▲
Front Controls (except backrest recline handle)	●
LH Controls	N/A
RH Controls	N/A
Heater	▲
Operator presence switch	▲
Slides between seat top and suspension	●
Standard connection widths	260mm
Optional connection widths	280mm(Order-- /CM110X)

Testing Mother regulation TMR\_1322/2014

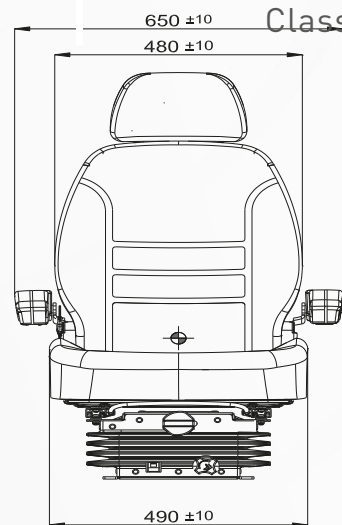
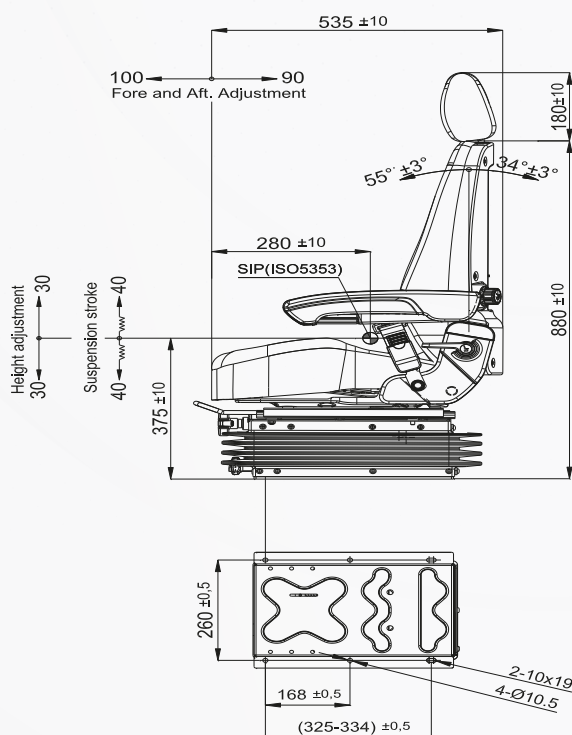

Class I,II,III