



Производитель ООО "МК Стиль"  
Manufacturer: LLC "FC Style"  
Россия, 440015, Пензенская обл.,  
Russia, 440015, Penza region.  
г.Пенза, ул. Аустрина, 166  
Penza, st. Austrina, 166  
тел.tel.: +7 (8412) 90-81-32

**Инструкция по сборке и эксплуатации мебели**  
**Furniture assembly and operation instructions**

**КВИК-СТЕП Кухня 1.2 м.**  
**QUICK-STEP Kitchen 1.2 m.**

**Габариты: Д.1 200 x В.2 150 x Г.600 мм**  
**Dimensions: L.1200 x H.2150 x D.600 mm**

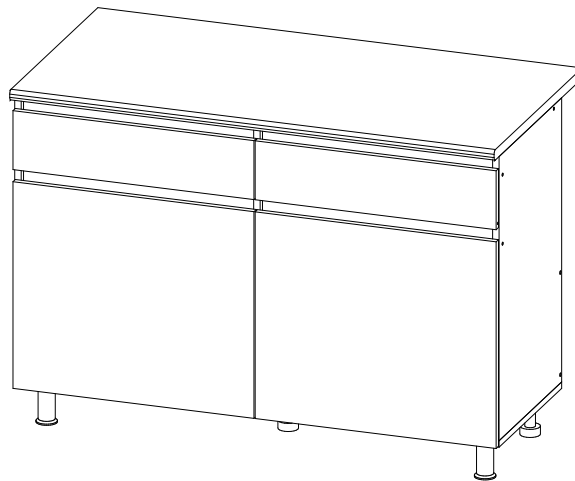
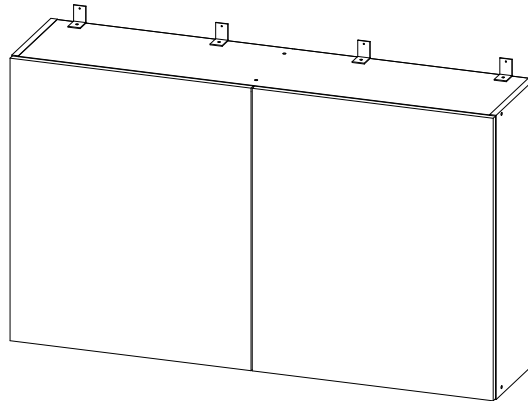

**Нагрузка на шариковые направляющие до 8кг. при равномерно распределённой нагрузке.**  
**Load on ball guides up to 8 kg with uniformly distributed load.**

**УНИВЕРСАЛЬНАЯ СБОРКА**  
**LUNIVERSAL ASSEMBLY**

Уважаемые покупатели!

Рекомендуем доверить сборку Вашей мебели профессиональным сборщикам







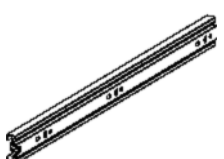

Dear customers!

We recommend entrusting the assembly of your furniture to professional assemblers.

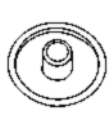
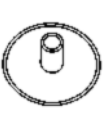
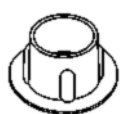
# Детализировка

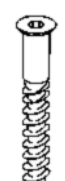
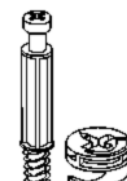
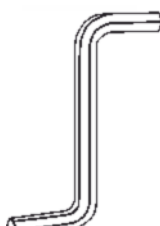
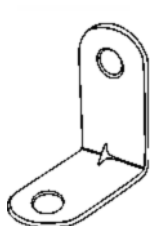
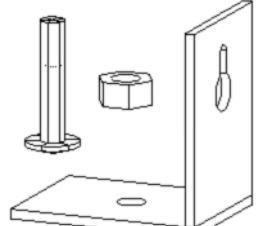
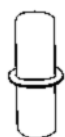
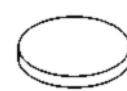
Упаковка	Материал	Поз.	Наименование	Кол-во	Размер	
1	ЛДСП 16 мм(Каркас)	1	Бок левый_М	1	704	426
	ЛДСП 16 мм(Каркас)	2	Перегородка	1	704	426
	ЛДСП 16 мм(Каркас)	3	Бок правый_М	1	704	426
	ЛДСП 16 мм(Каркас)	14	Бок левый (Сушка)	1	704	266
	ЛДСП 16 мм(Каркас)	15	Перегородка	1	661	266
	ЛДСП 16 мм(Каркас)	16	Бок правый (Сушка)	1	704	266
	Фурнитура в коробе/комплектующая	500	Фурнитура (ВНУТРИ УПАКОВКИ)	1		
2	ЛДСП 16 мм(Каркас)	17	Вязка верхняя	1	1 168	266
	ЛДСП 16 мм(Каркас)	18	Вязка нижняя	1	1 168	266
	ЛДСП 16 мм(Каркас)	4	Крышка_М	1	1 200	426
	ЛДСП 16 мм(Каркас)	5	Планка	7	576	74
	ЛДСП 16 мм(Каркас)	7	Панель_(передняя)	1	597	146
	ЛДСП 16 мм(Каркас)	9	Фасад ящика (Кромка_ПАЗ)	1	597	146
	ЛДСП 16 мм(Фасад)	6	Полка	1	576	420
	ЛДСП 16 мм(Фасад)	19	Полка	1	584	250
	ЛХДФ 3,2 мм_БЕЛОЕ	13	Дно ящика	1	548	405
	ЛХДФ 3,2 мм_БЕЛОЕ	22	Задняя стенка	1	715	597
	ЛХДФ 3,2 мм_БЕЛОЕ	23	Задняя стенка	2	690	597
	Планка соединительная для ДВП	42	_Планка соединительная для ДВП	1	661	
	Столешница 26 мм	21	_Столешн(Ф)	1	1 200	600
3	ЛДСП 16 мм(Фасад)	10	Бок ящика лев.(Зпр)	1	400	74
	ЛДСП 16 мм(Фасад)	11	Бок ящика прав.(Зпр)	1	400	74
	ЛДСП 16 мм(Фасад)	12	Задняя стенка ящика	1	519	74
	ЛДСП 16 мм(Фасад)	8	Створка	2	597	512
	ЛДСП 16 мм(Фасад)	20	Створка	2	597	700

Набор фурнитуры / Set of fittings

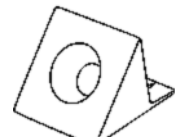
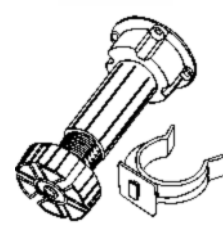
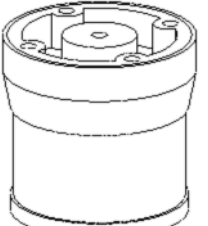
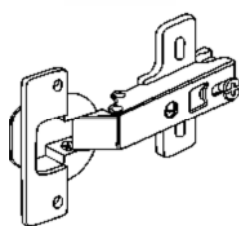
				
400mm x1	x1	x34	x4	D 8 MM x5
				
D 5 MM x8	6,3*50 MM x34	x4	x1	30x30x15 MM x10
				
x4	x16	x10	2 * 20 MM x80	4*30 MM x2
				
3,5*15 MM x90	x3	x3	x2	x8

- КРОМОЧНЫЙ МАТЕРИАЛ / EDGE MATERIAL

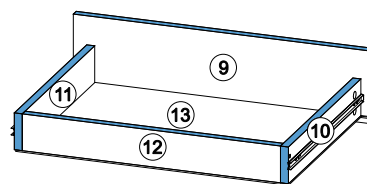
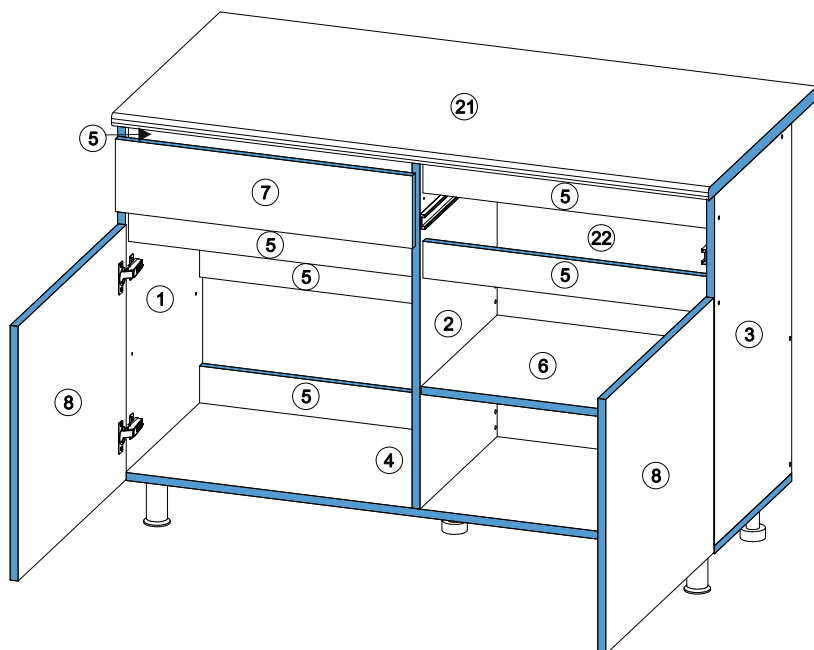
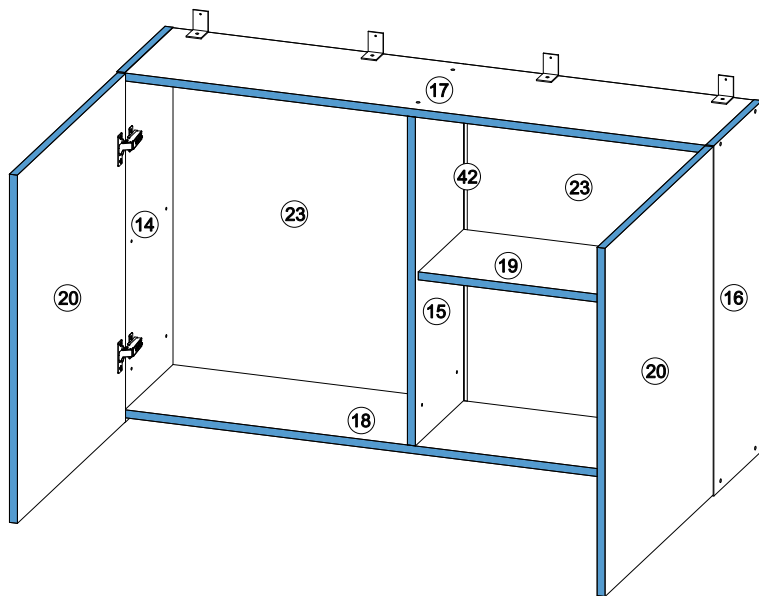

**В процессе сборки Вам понадобятся:  
During the assembly process you will need:**

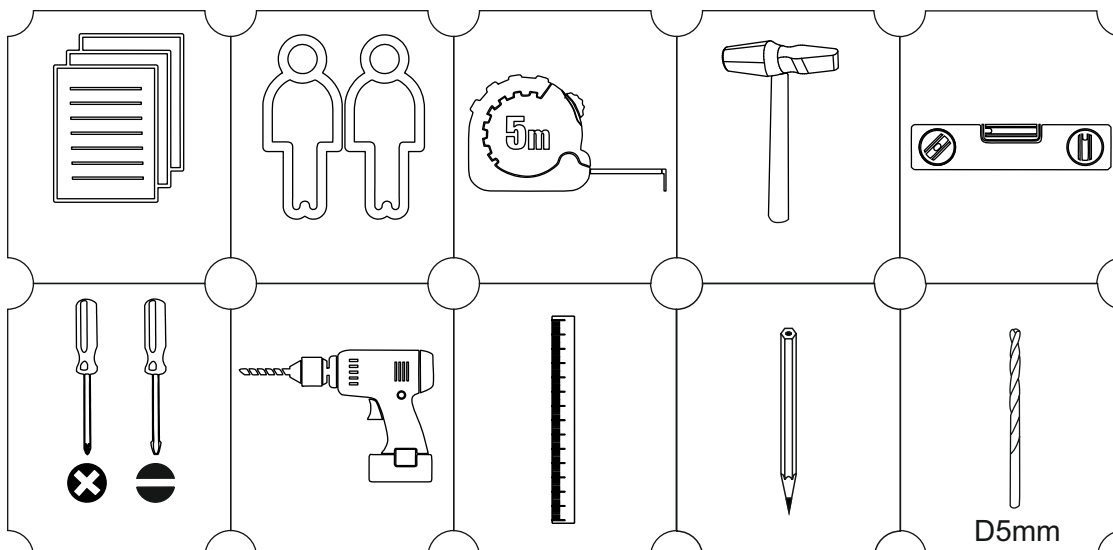

1

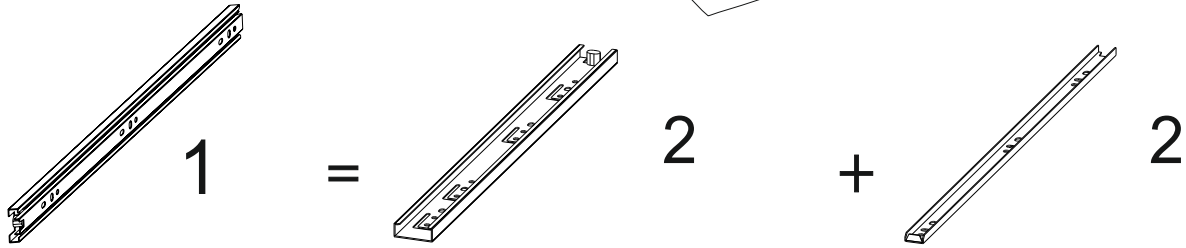
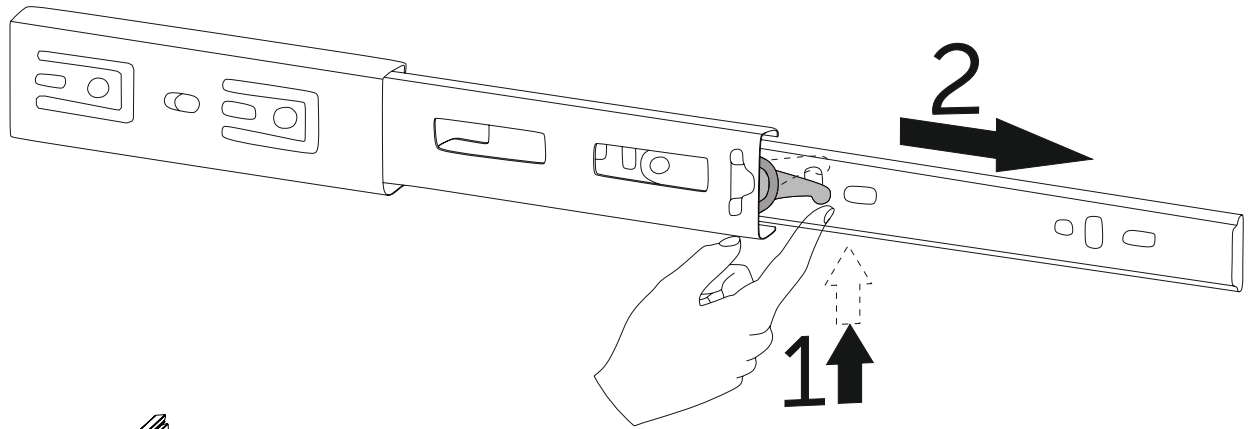

2

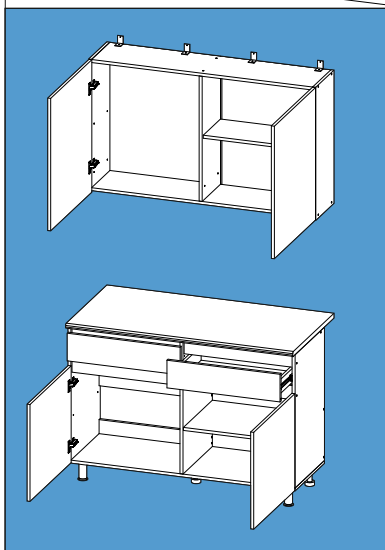
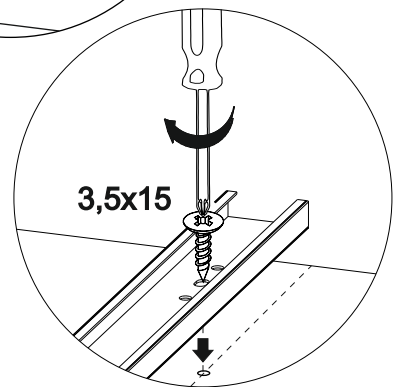
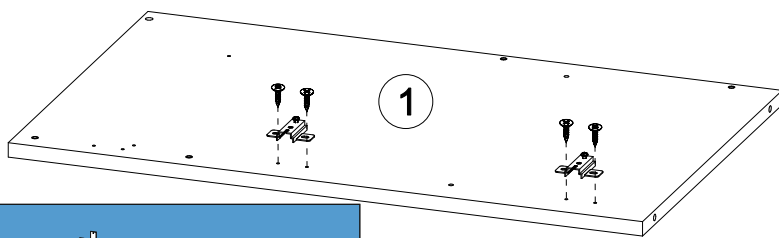
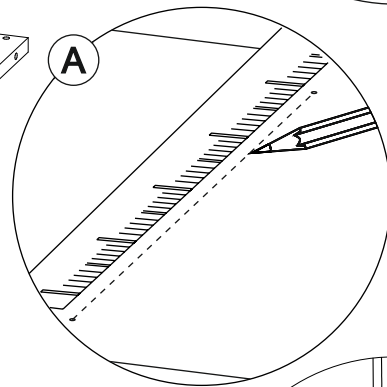
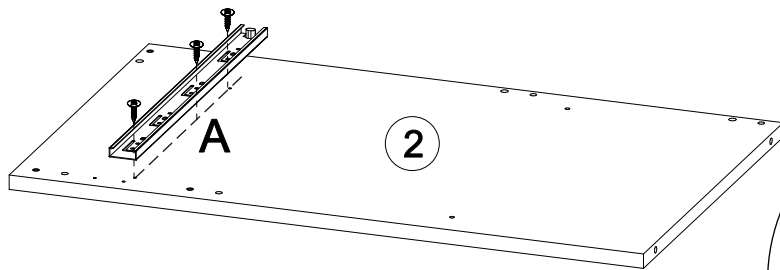
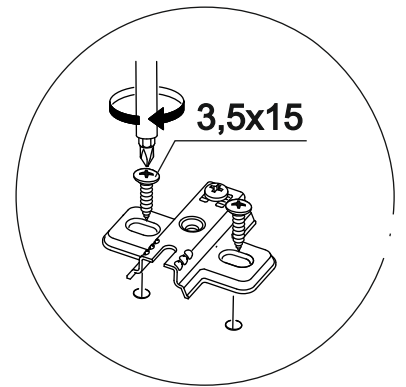
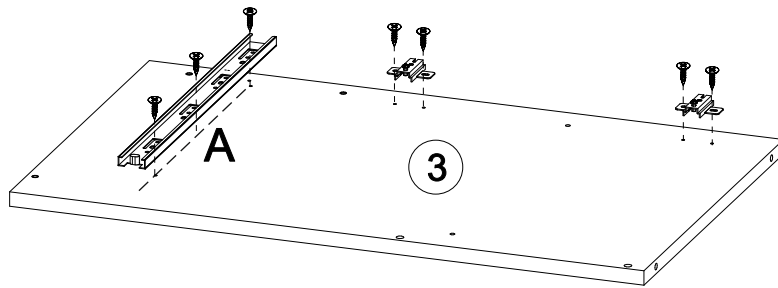

x 14

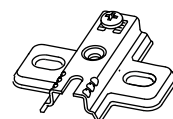

x 4

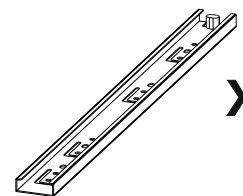

x 2

3

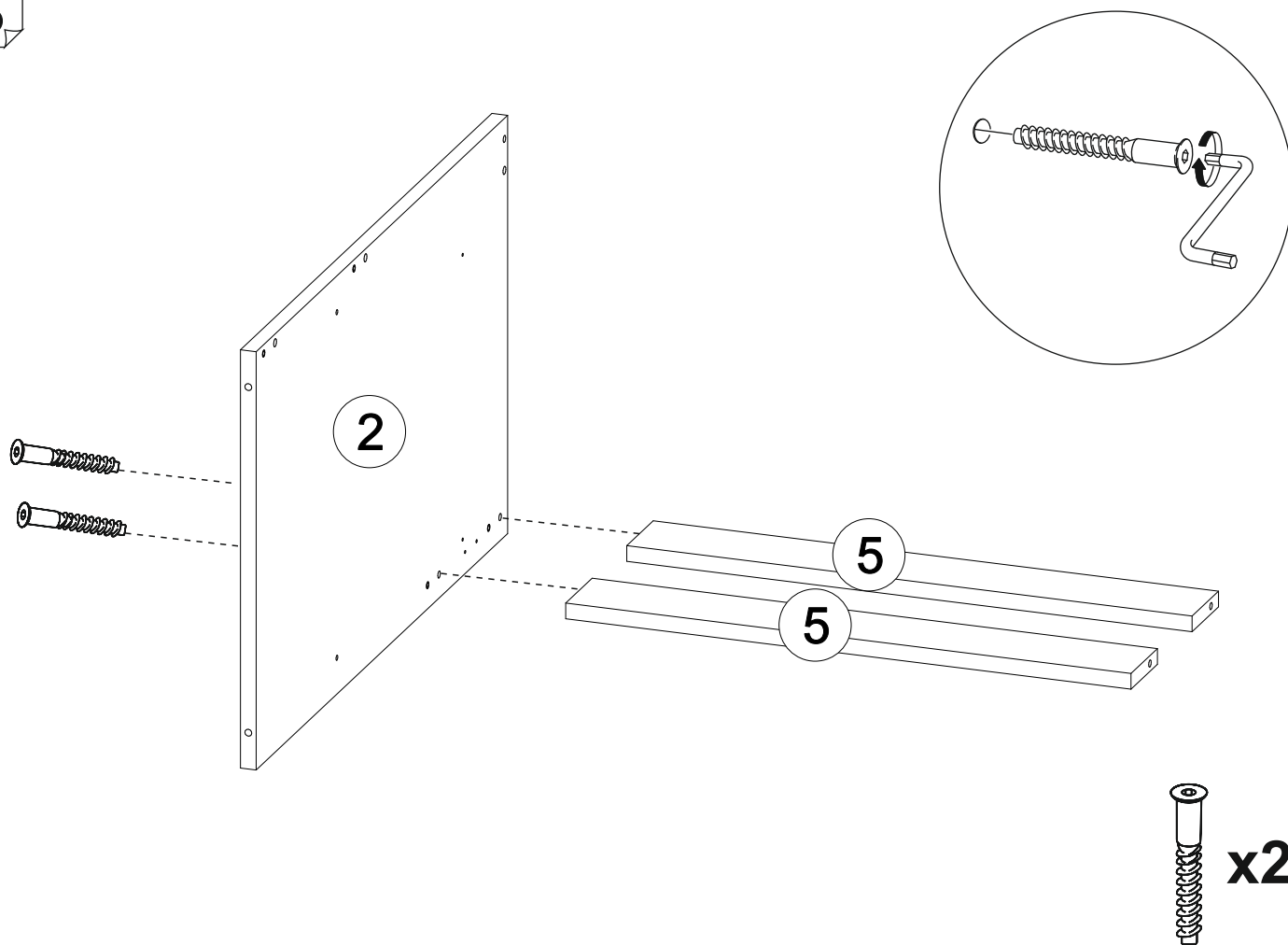

4

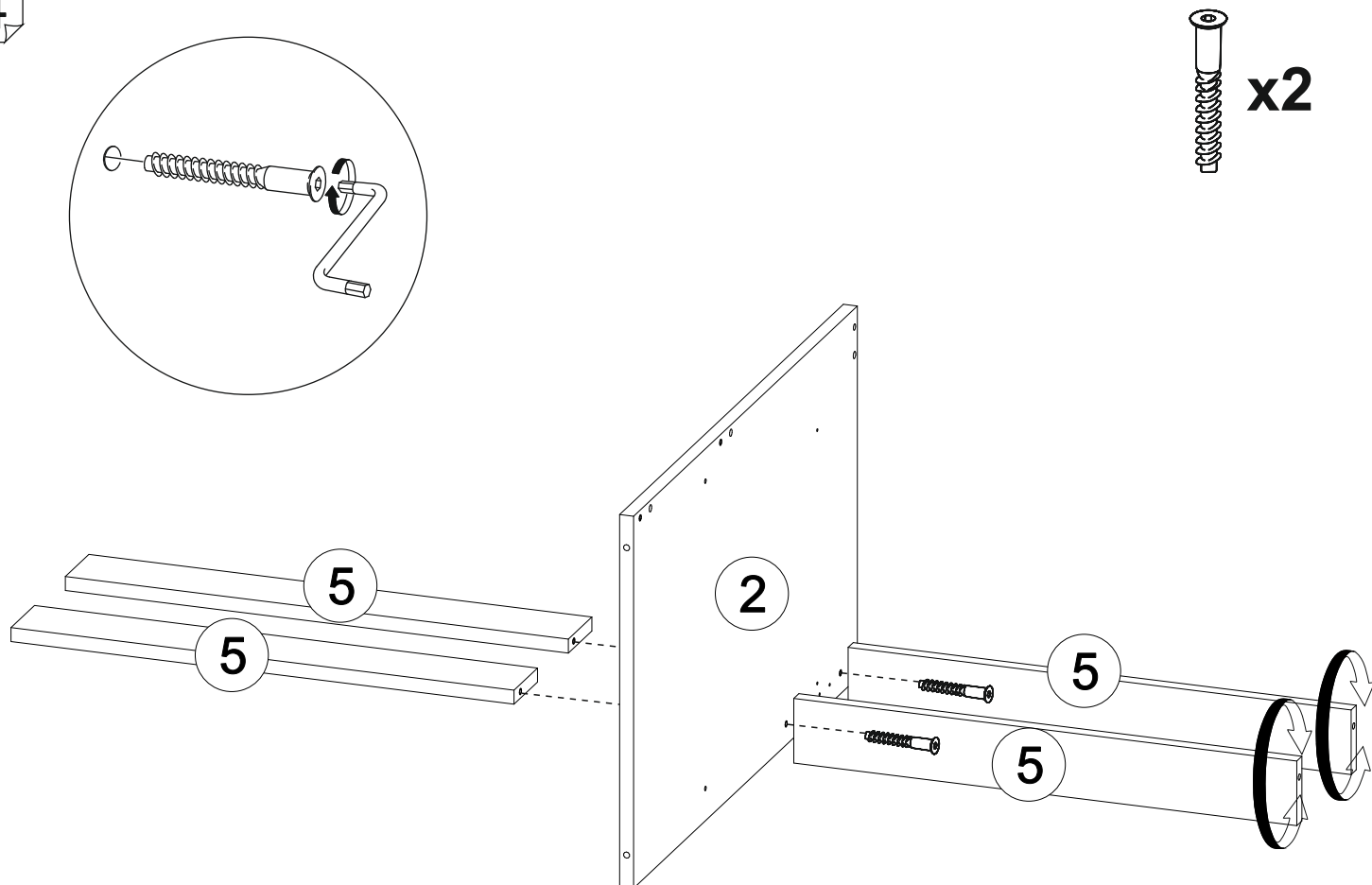

5

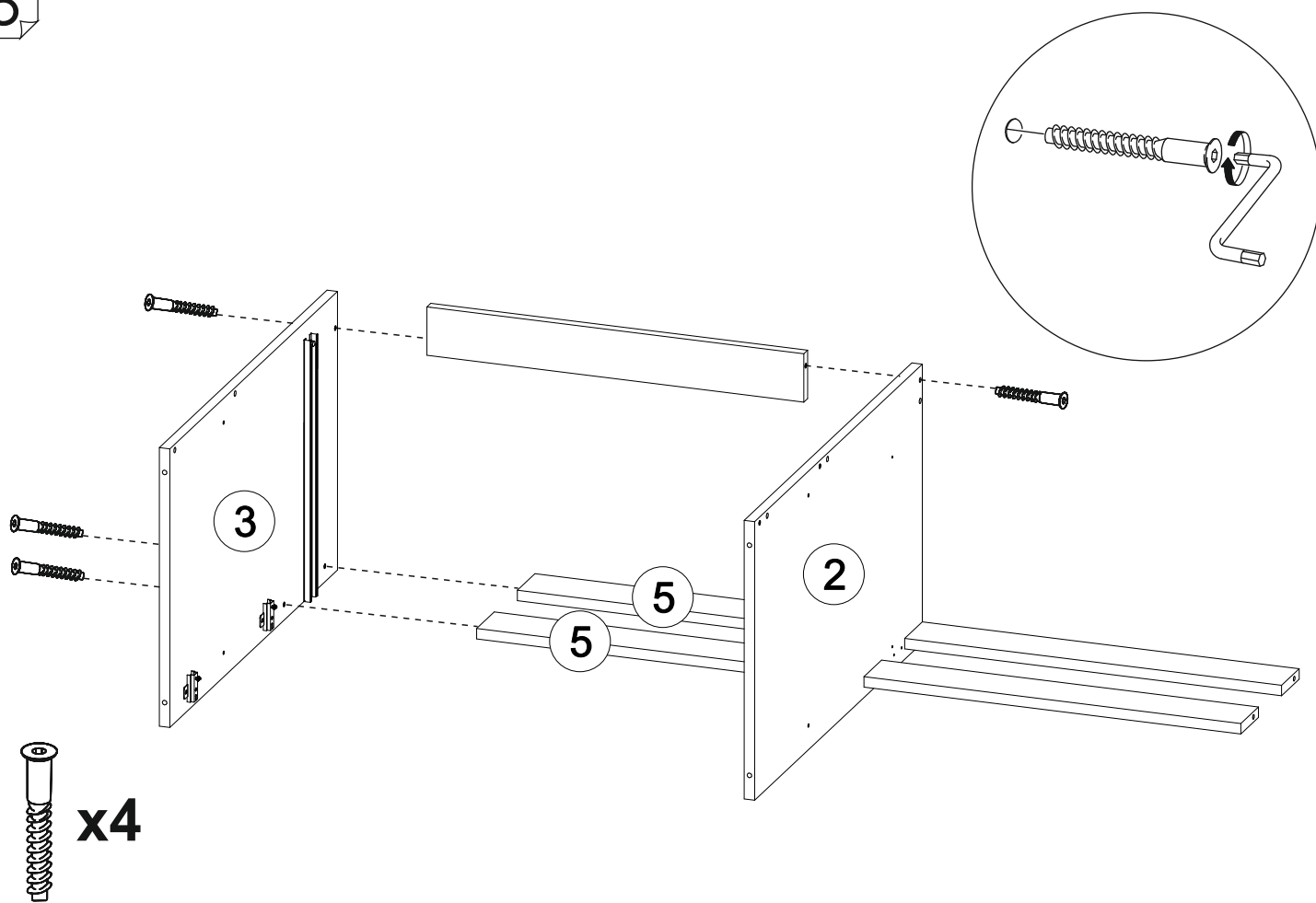

6

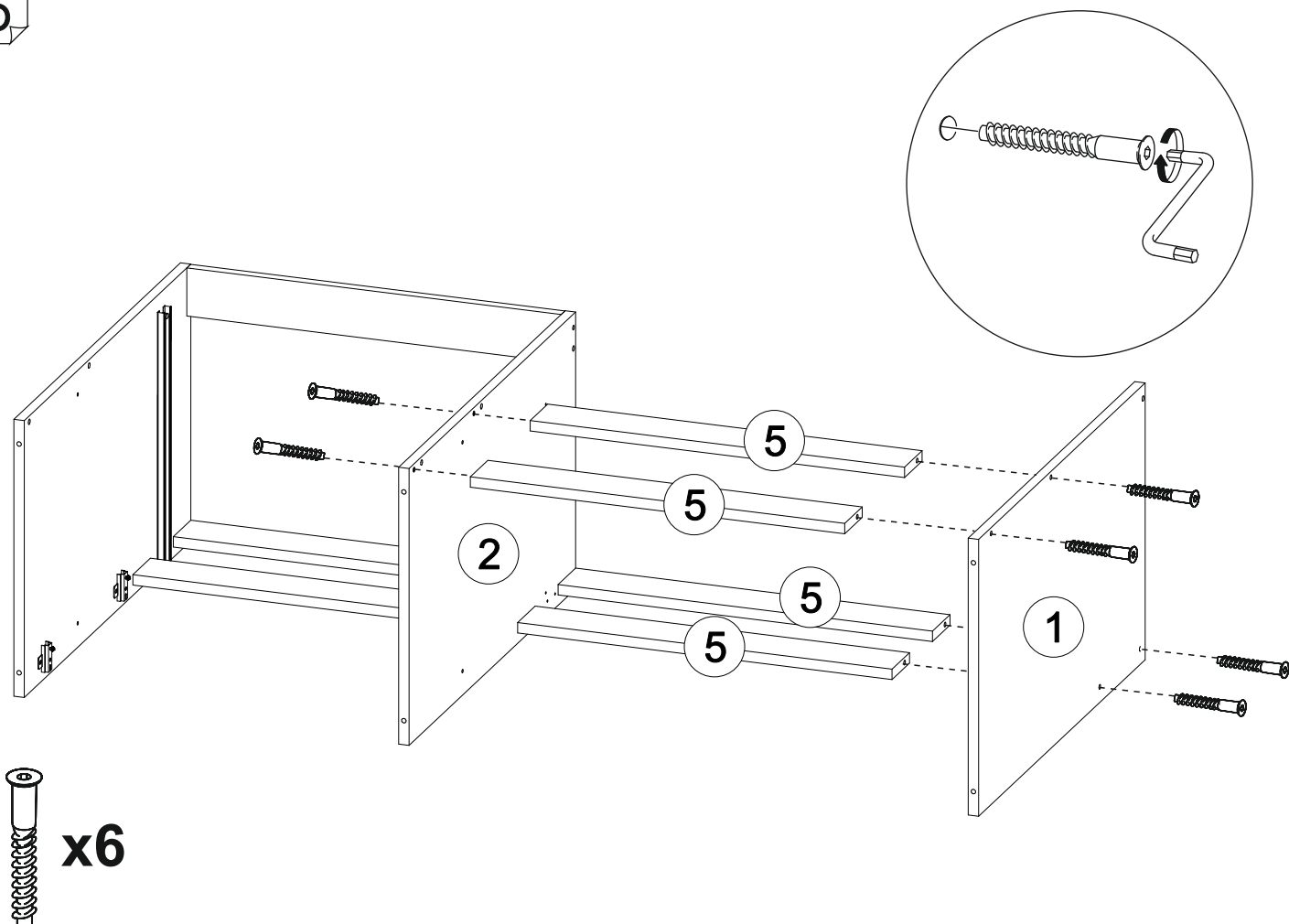

7

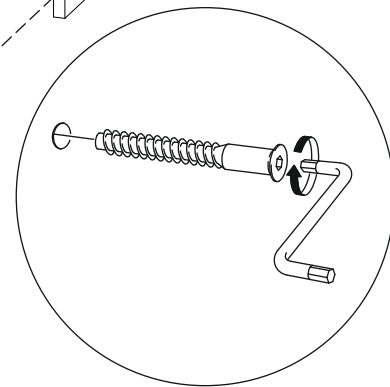
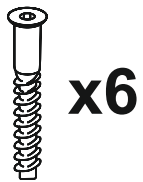
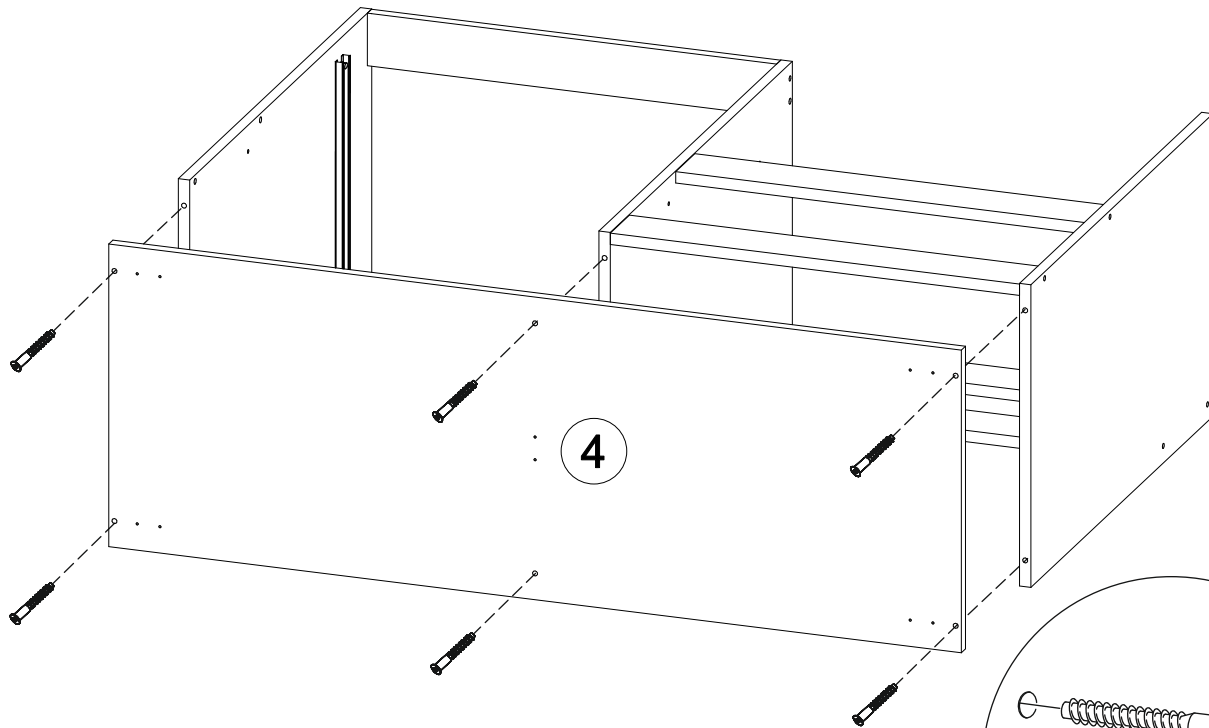

8

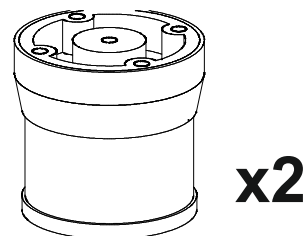
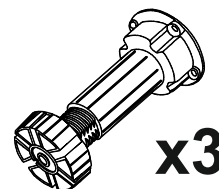
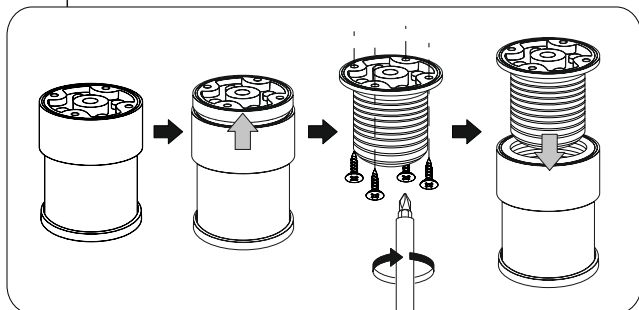
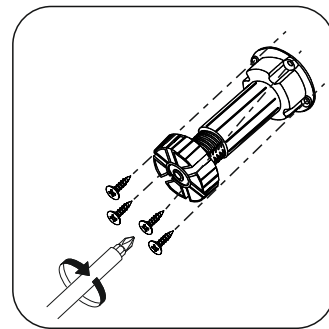
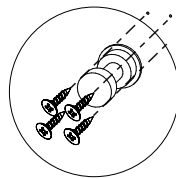
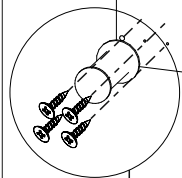
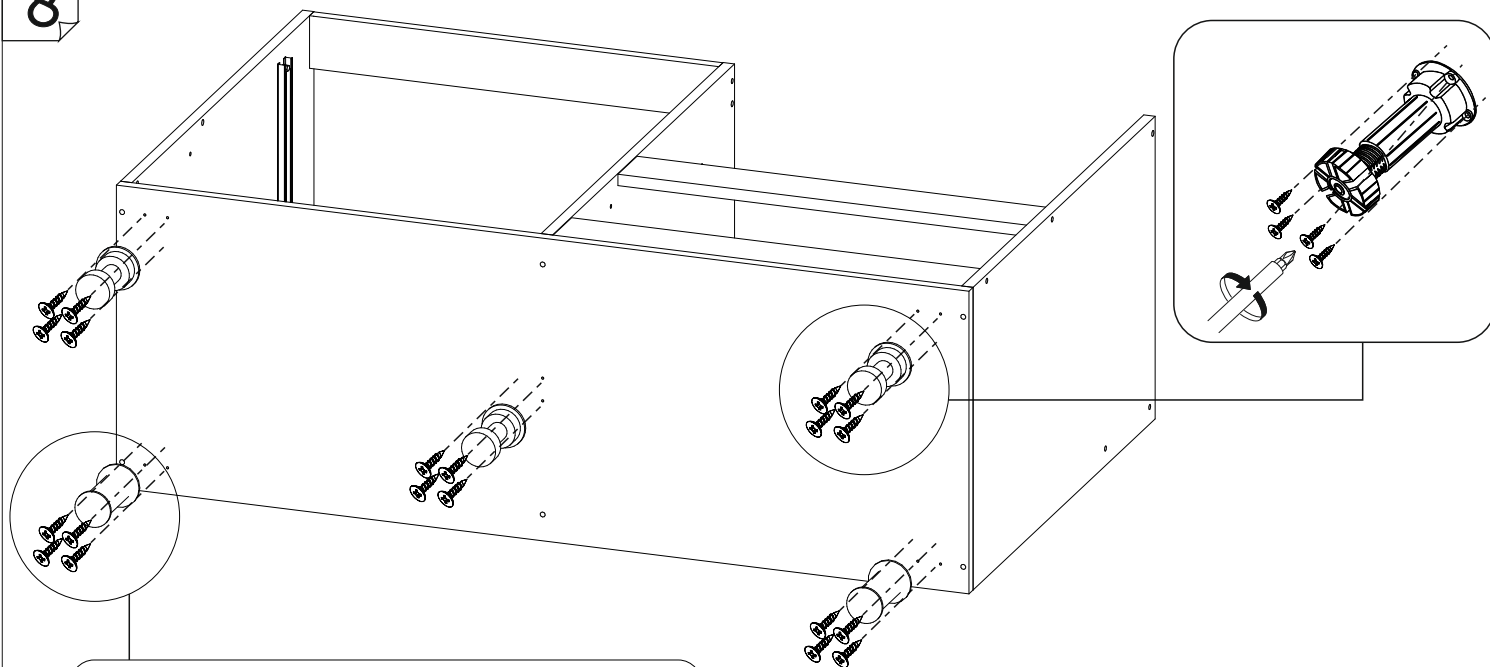

9

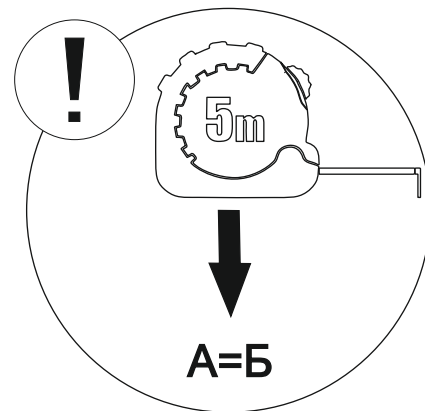
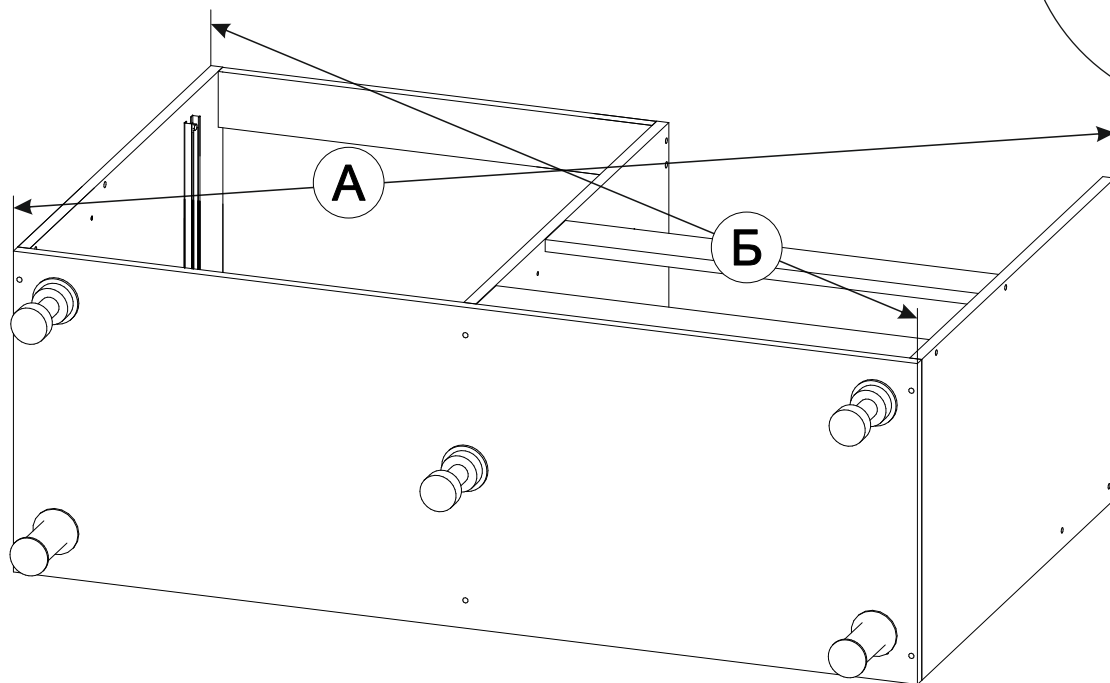

10

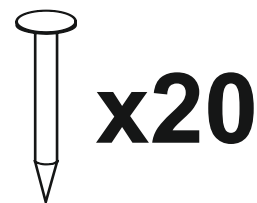
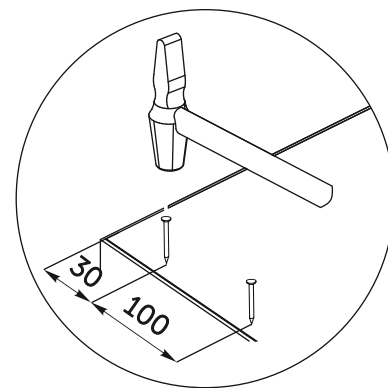
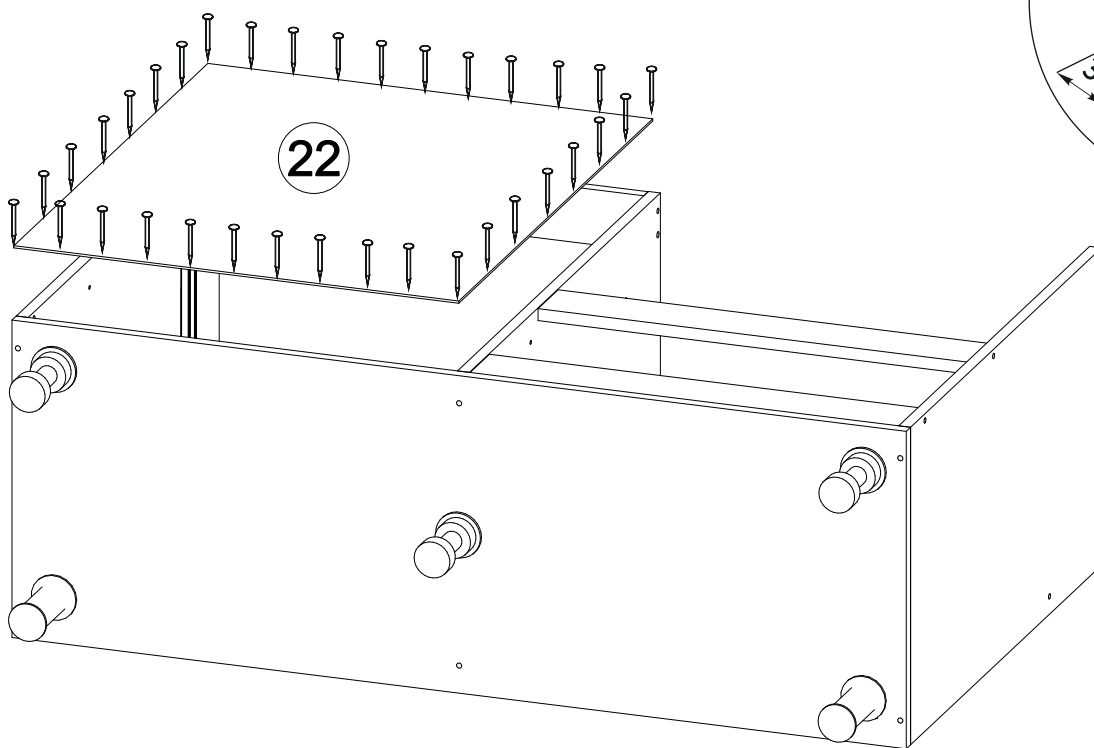

11

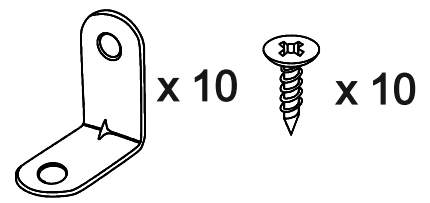
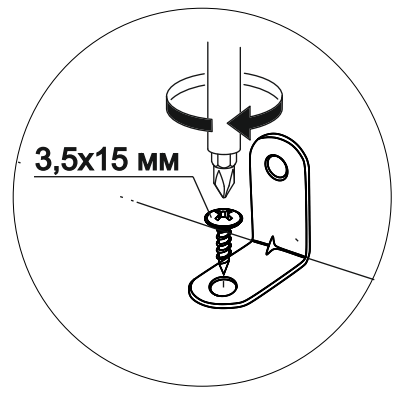
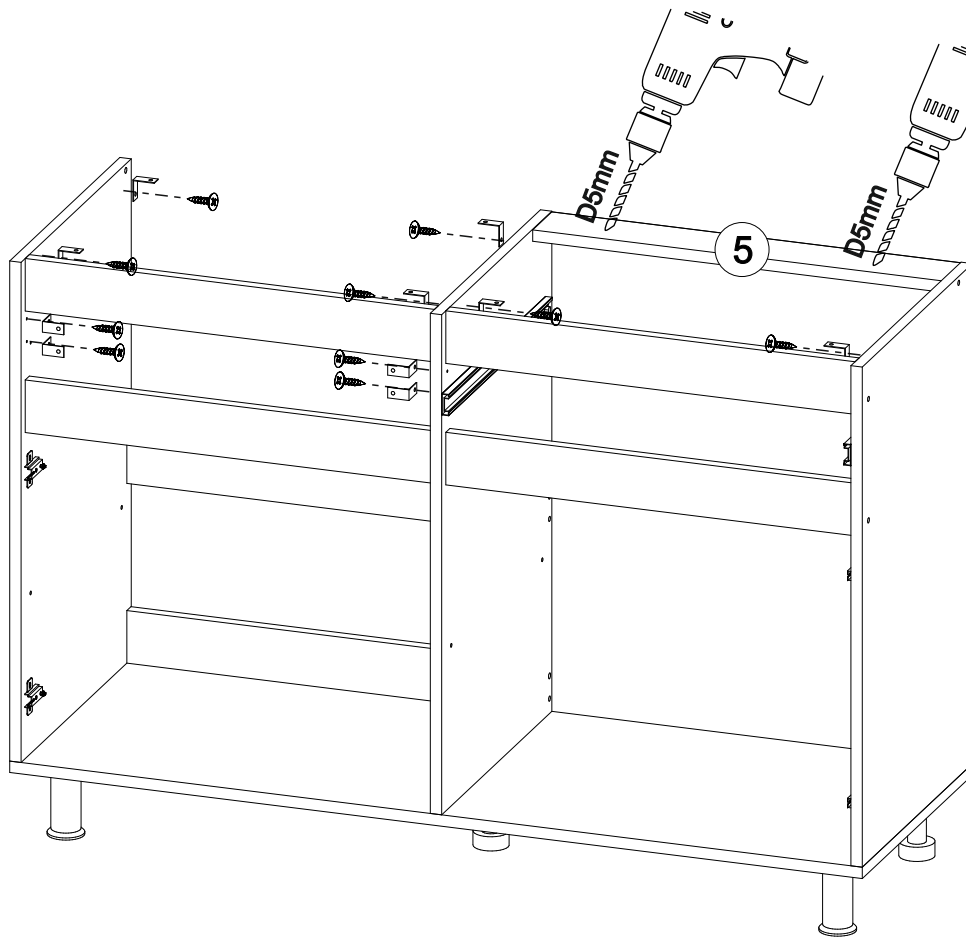

12

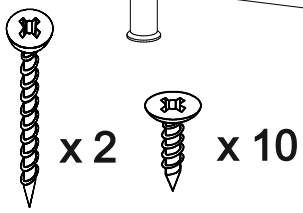
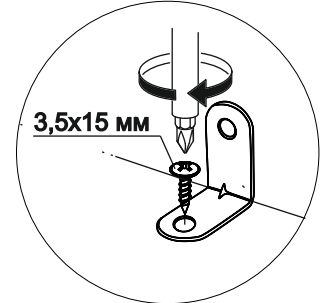
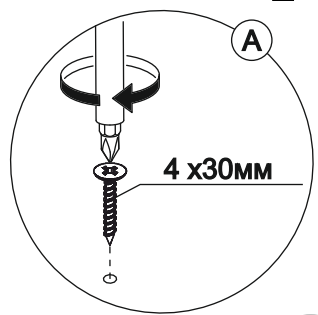
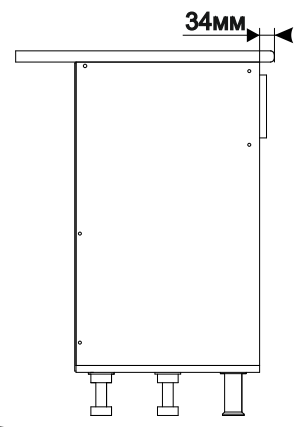
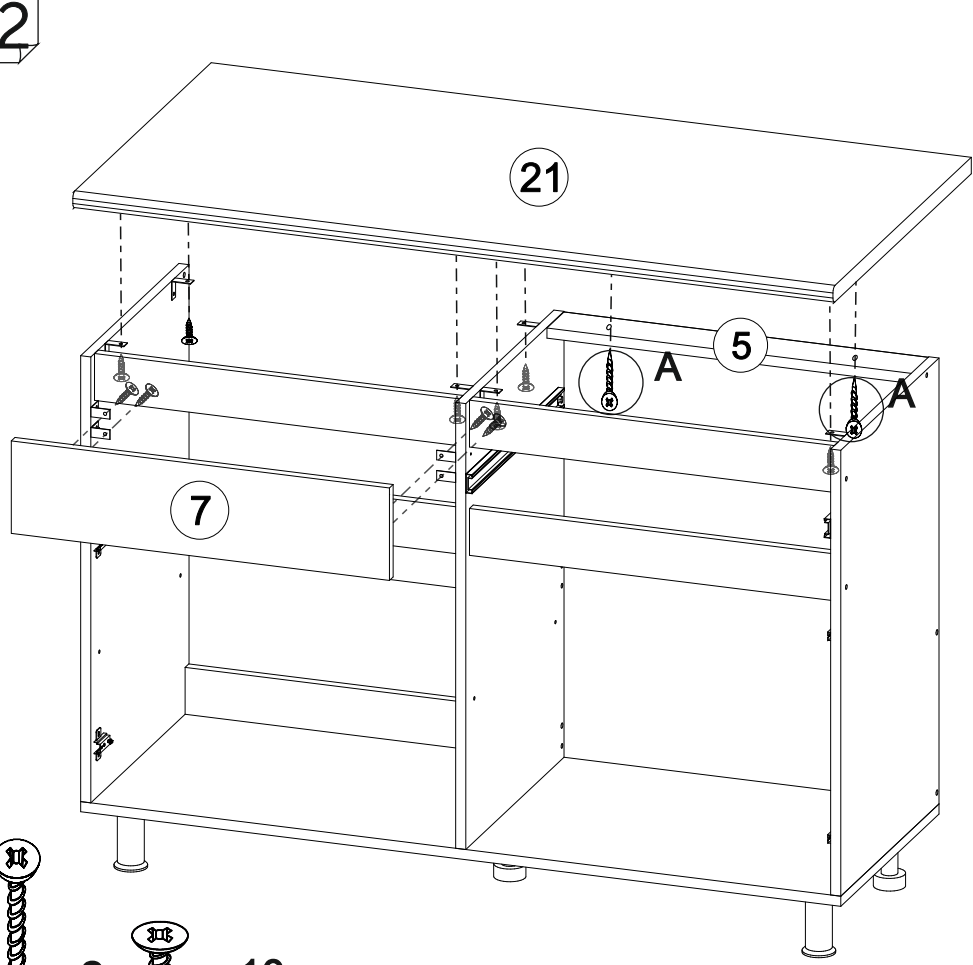

13

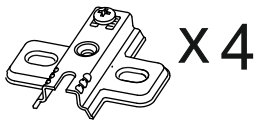
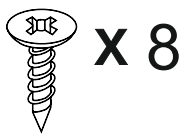
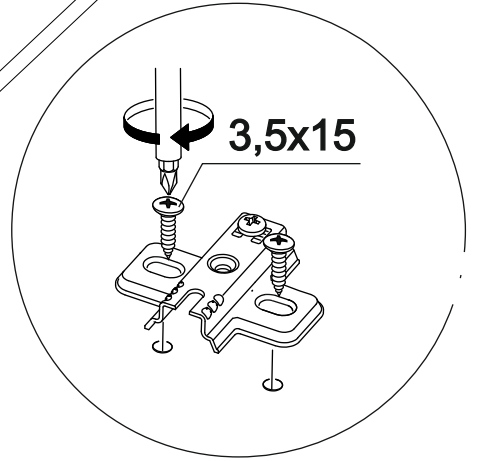
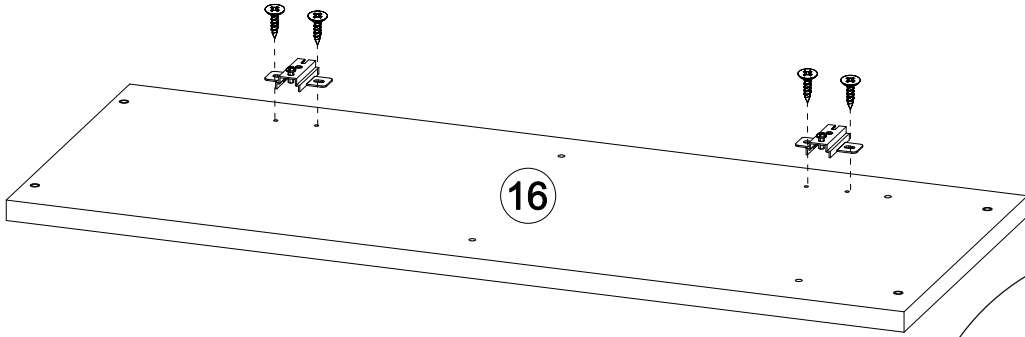
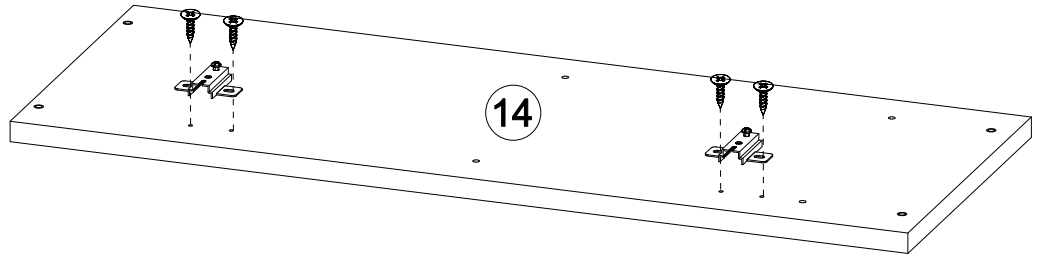

14

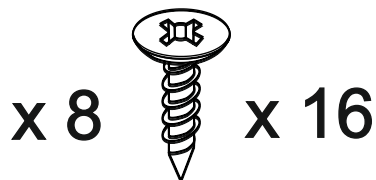
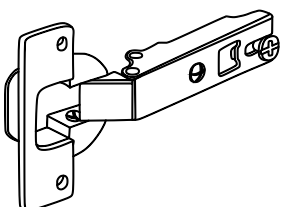
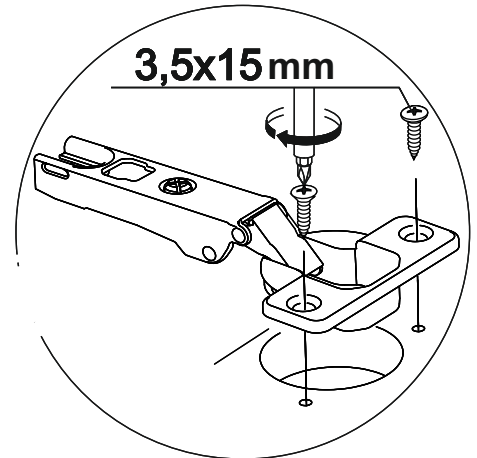
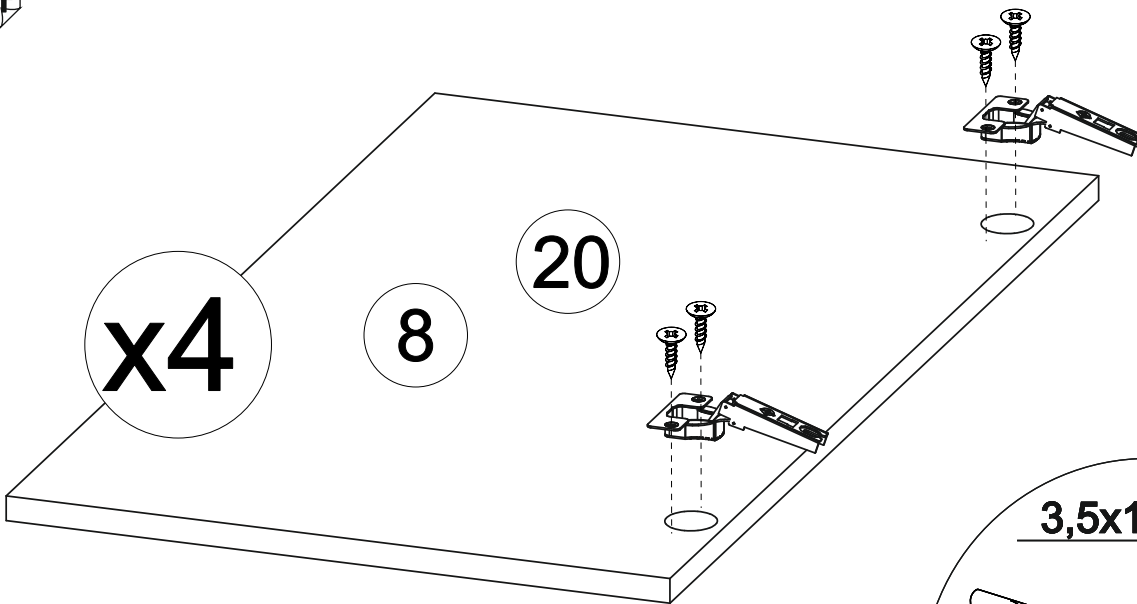

15

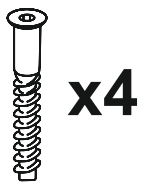
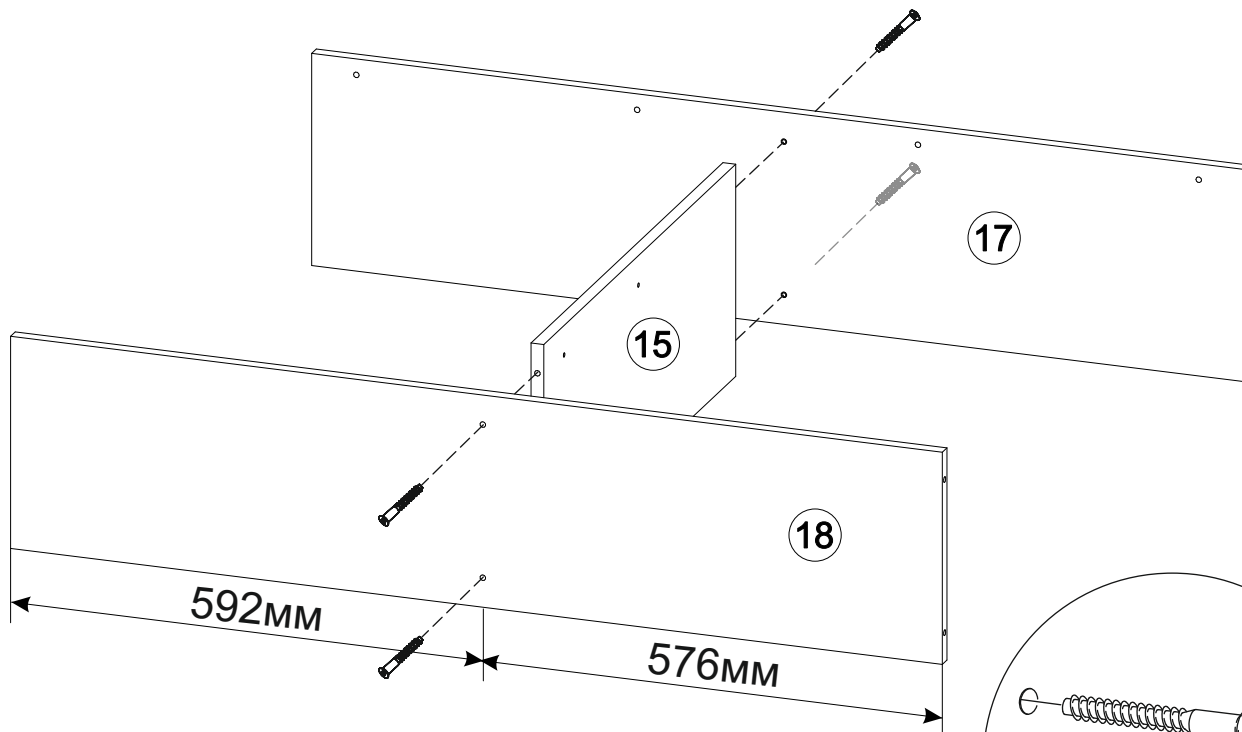

16

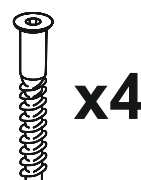
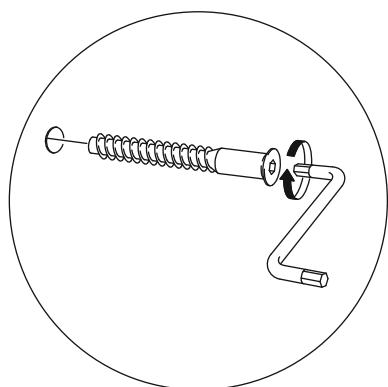
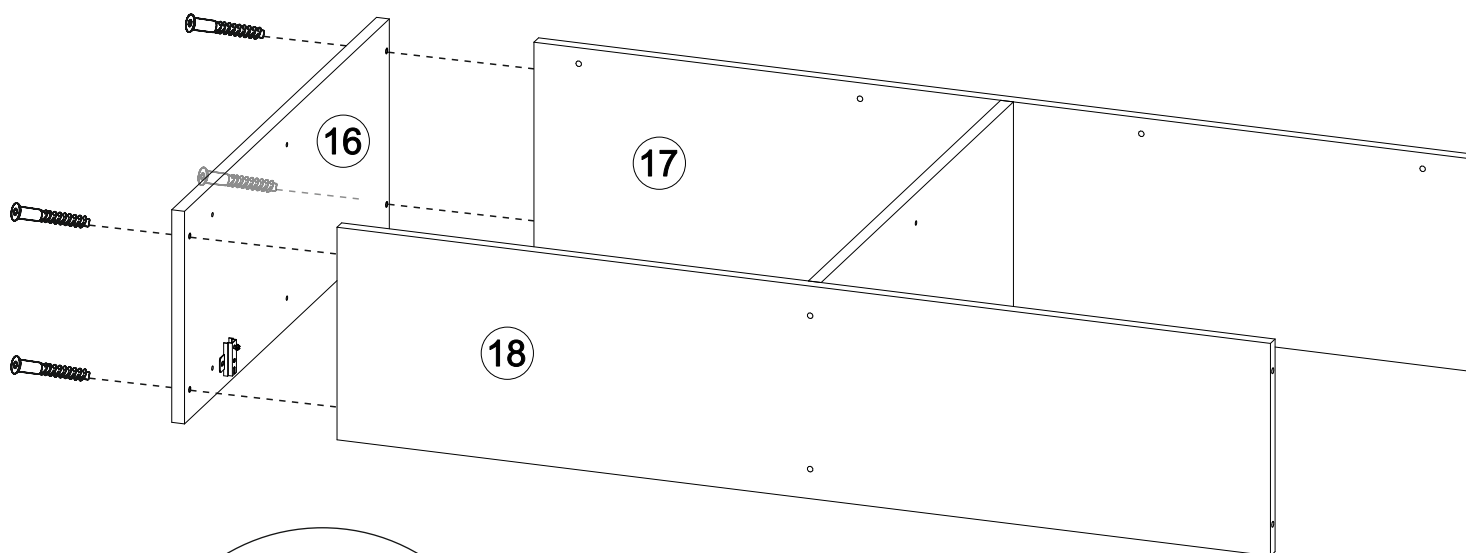

17

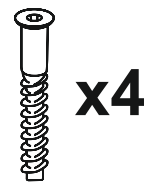
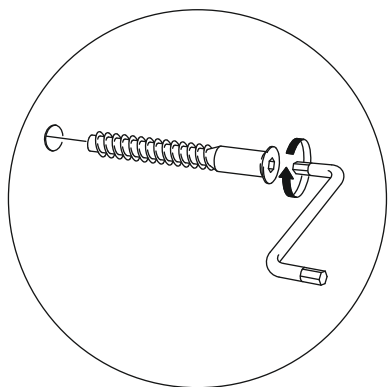
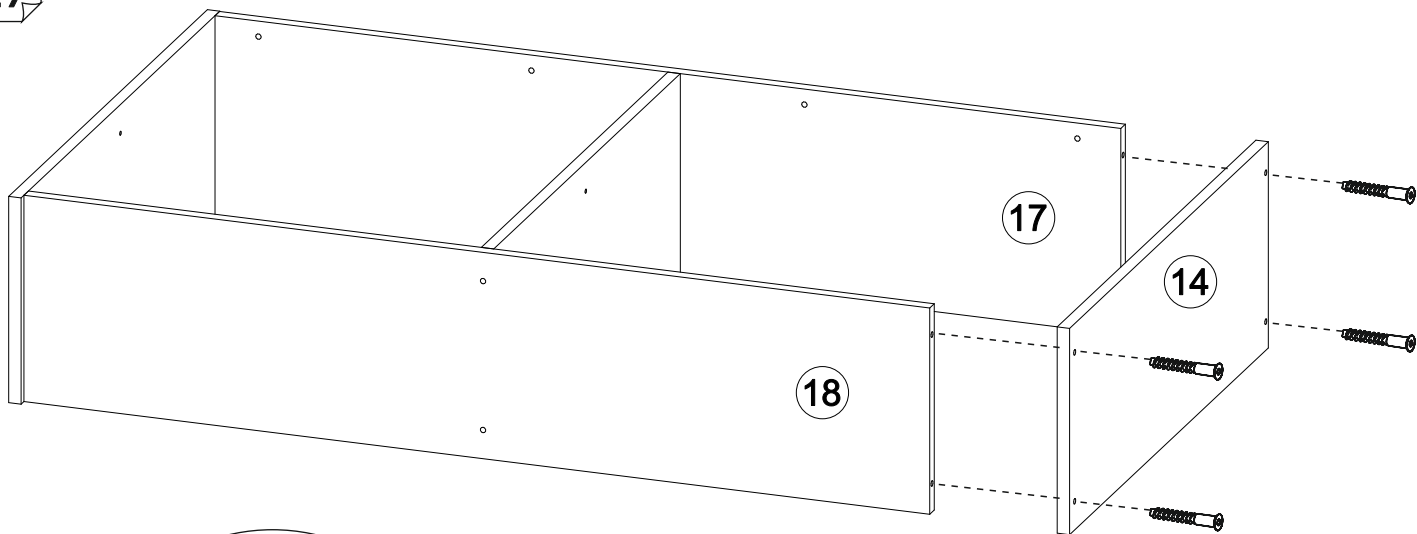

18

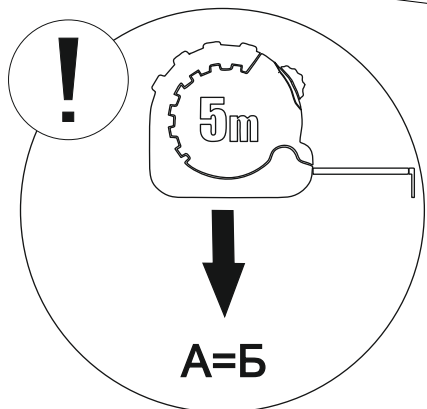
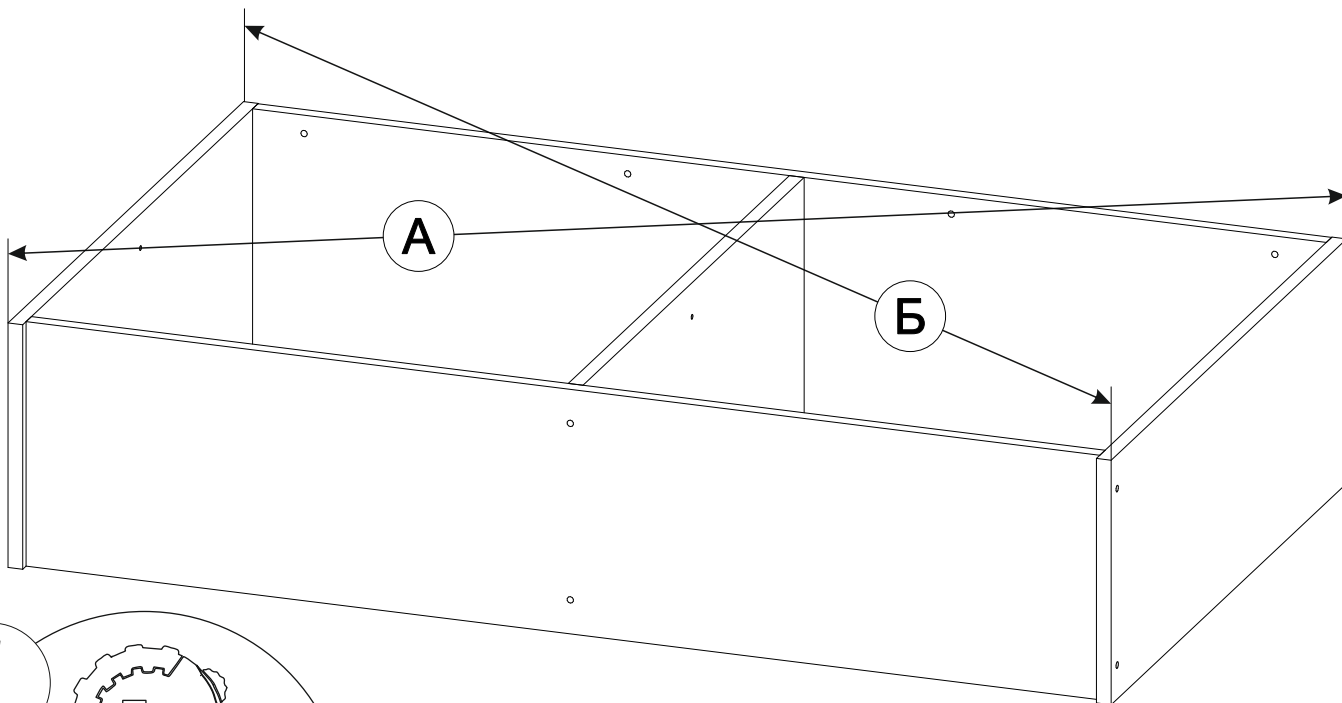

19

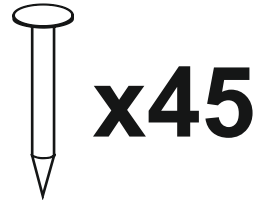
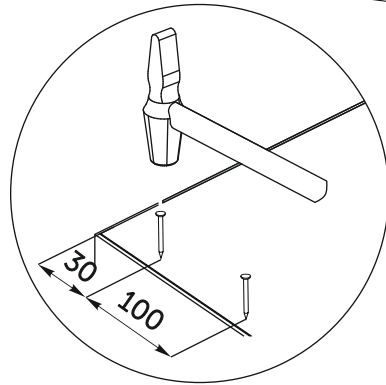
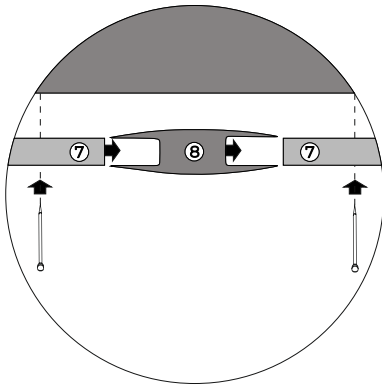
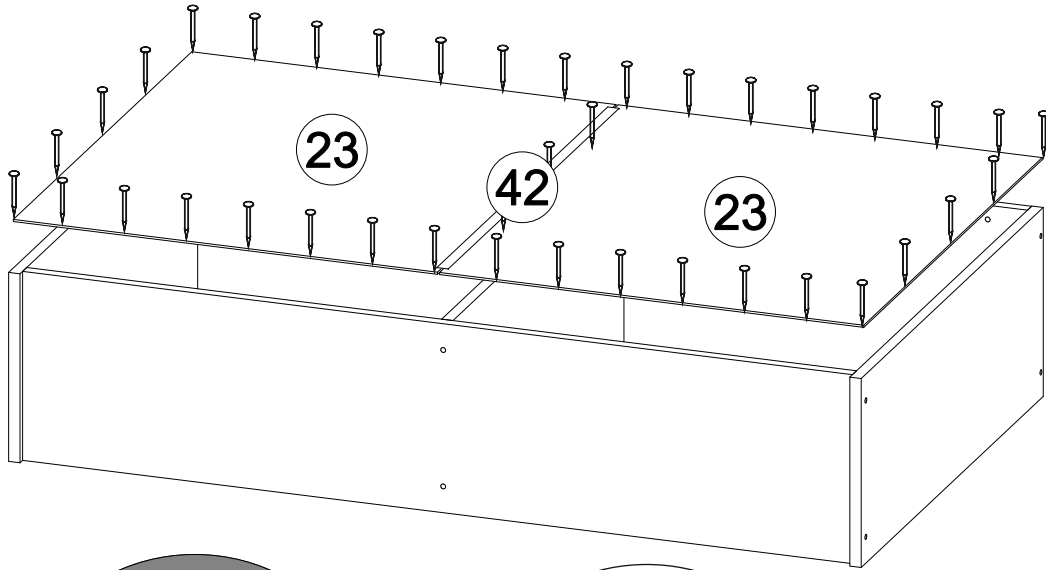

20

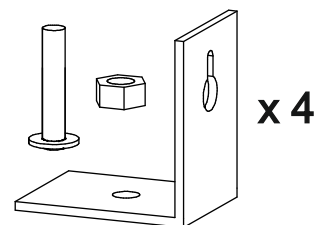
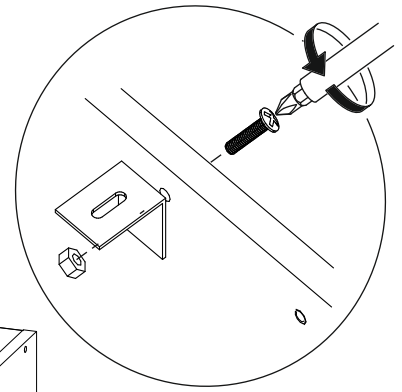
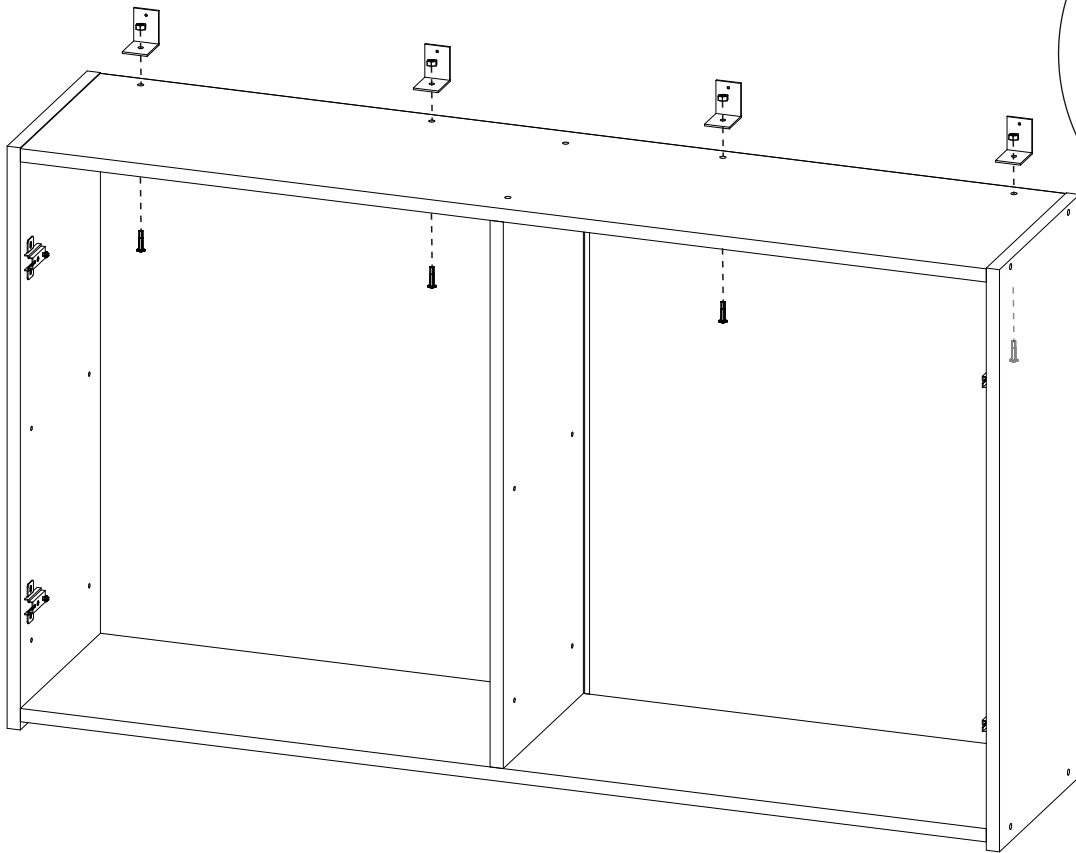

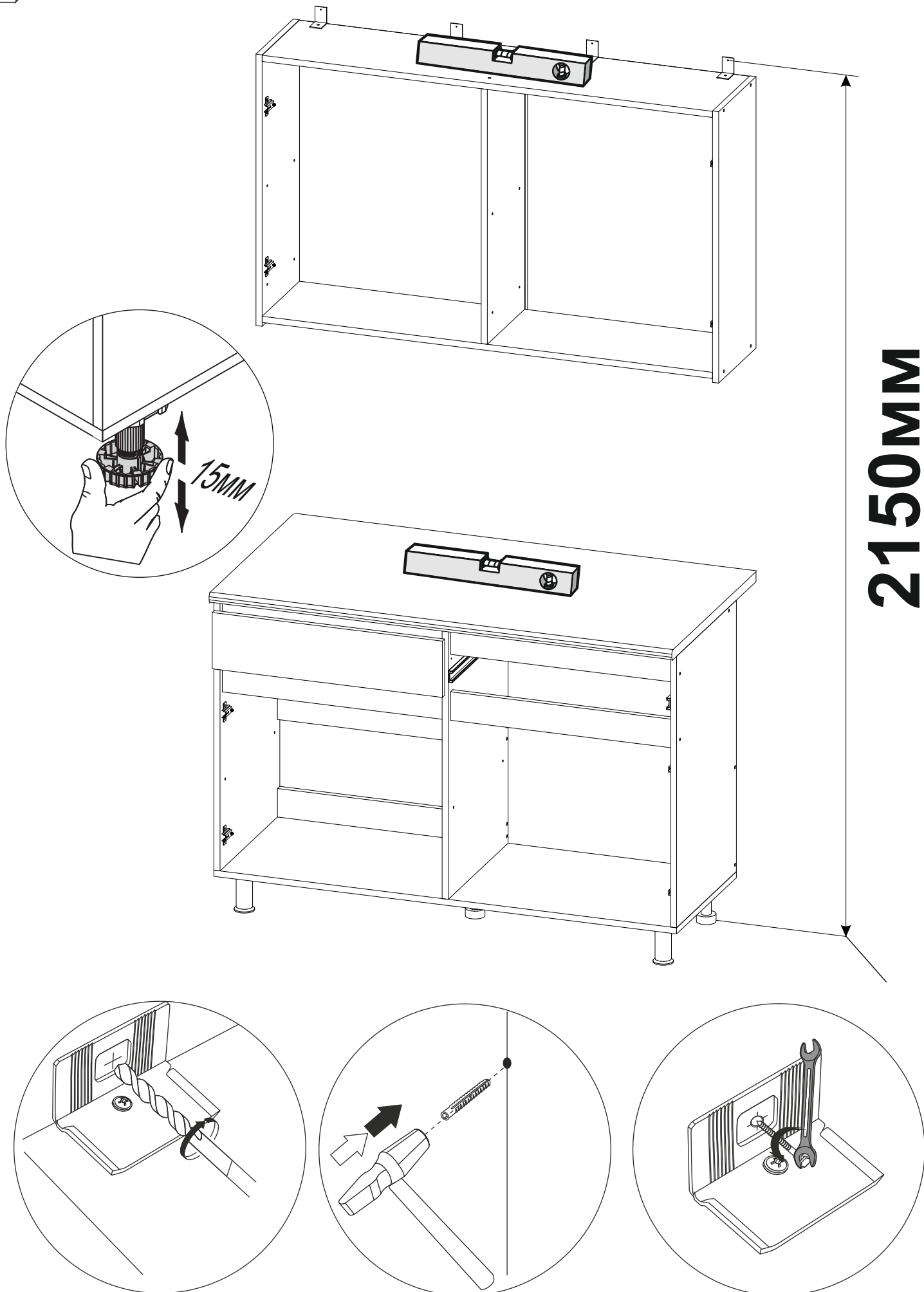

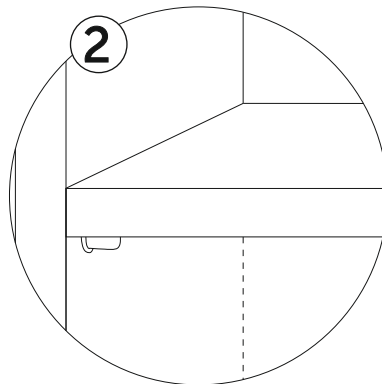
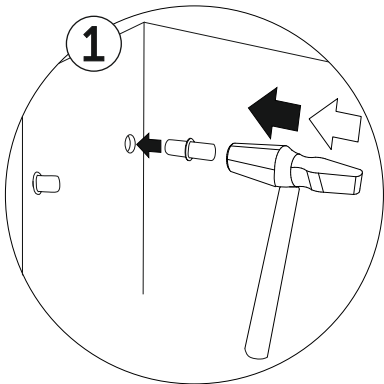
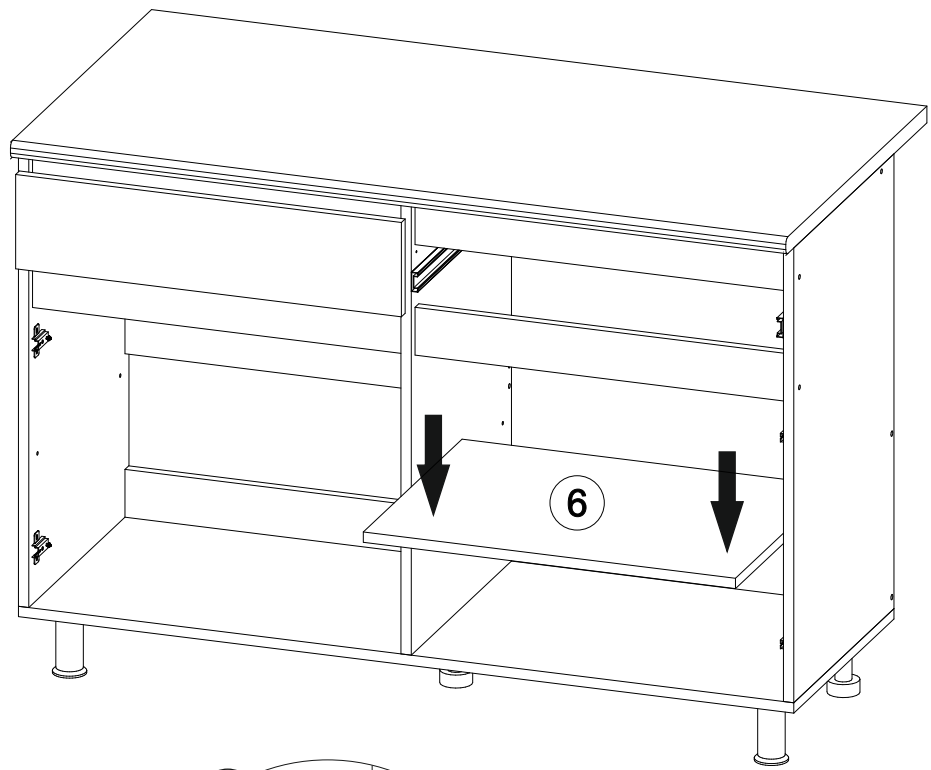
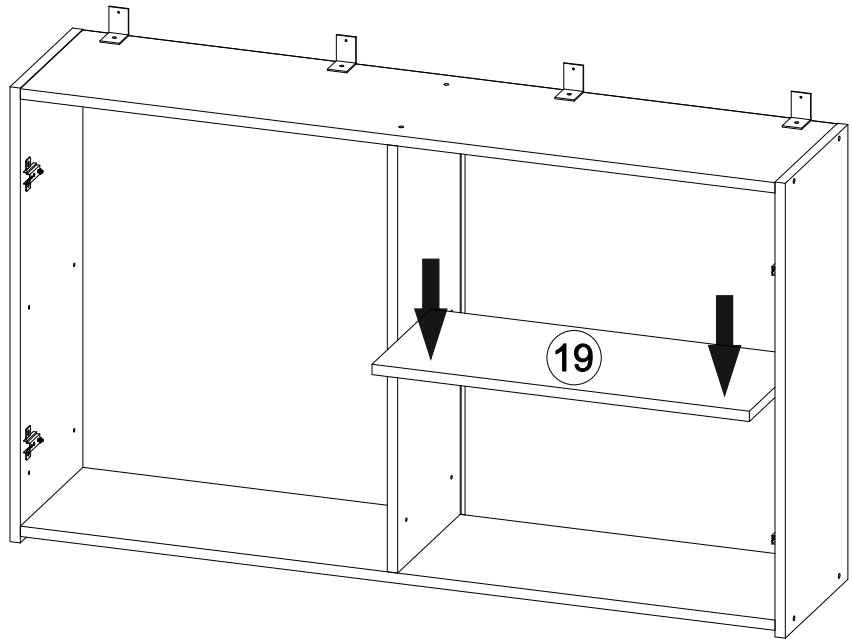

1

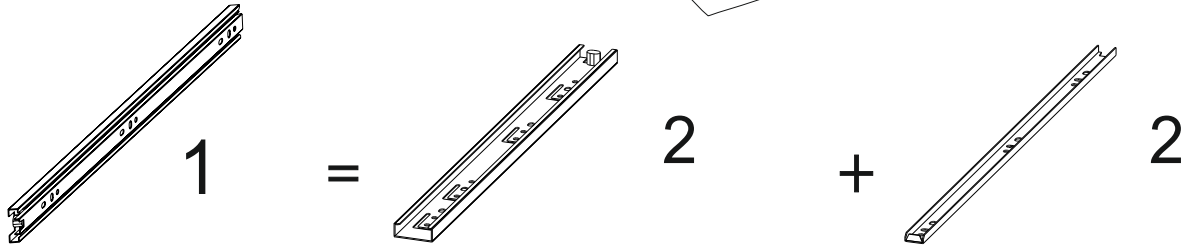
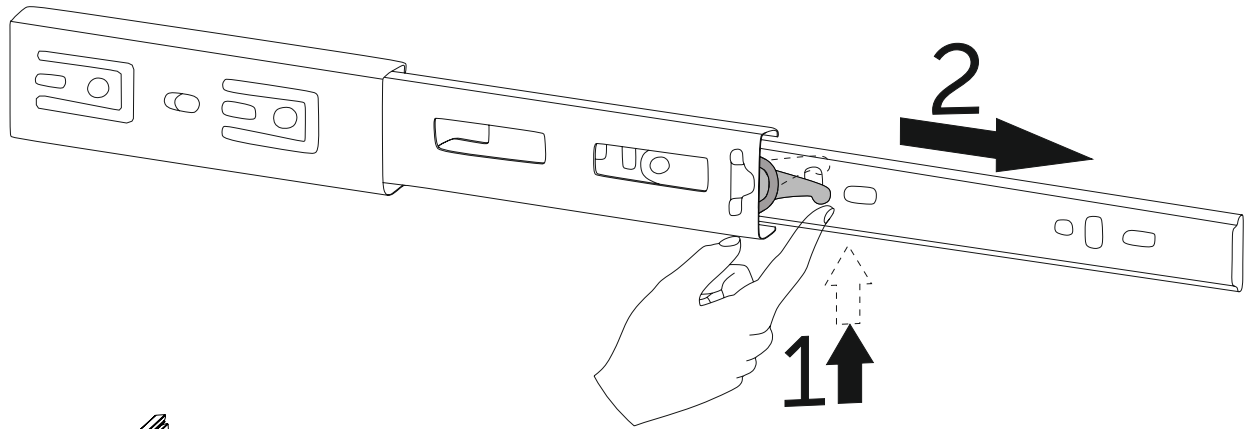

2

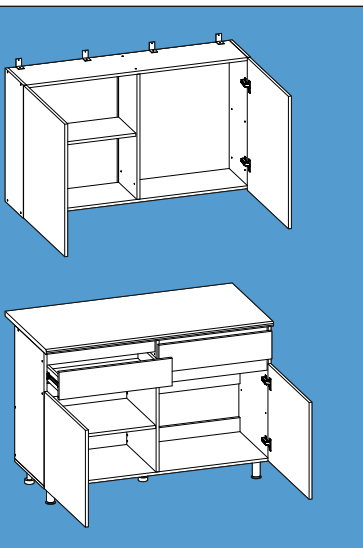
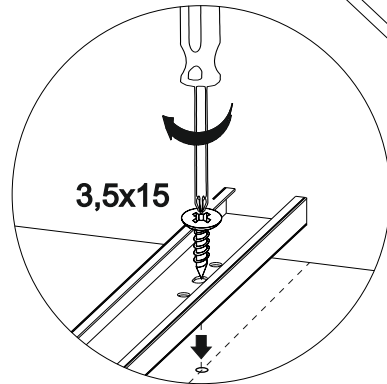
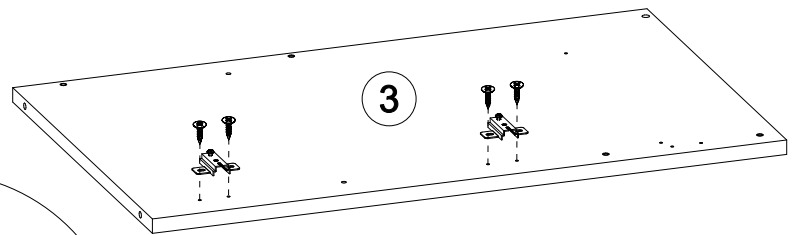
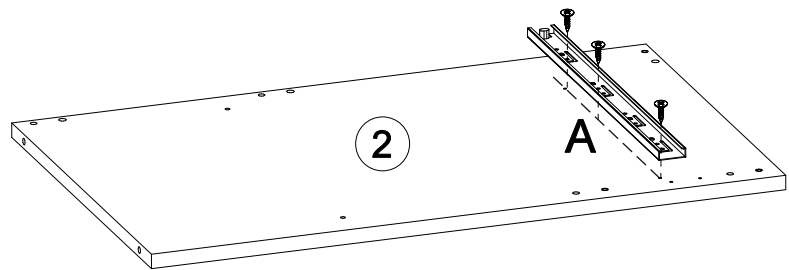
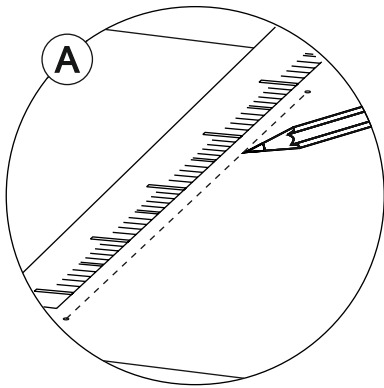
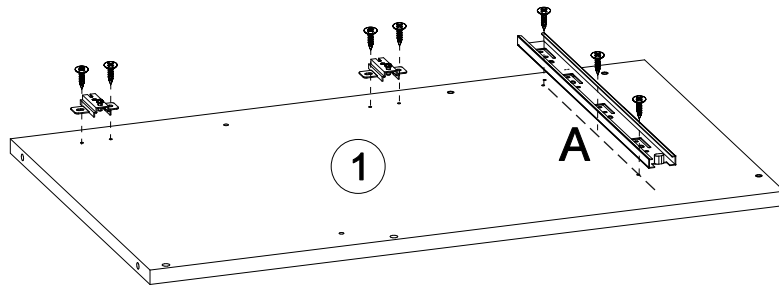
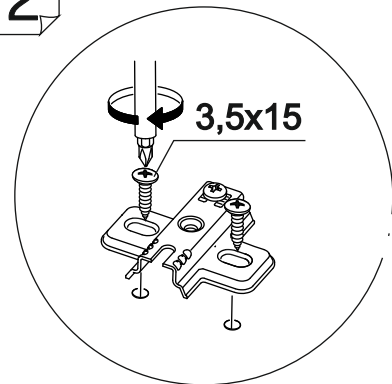

3

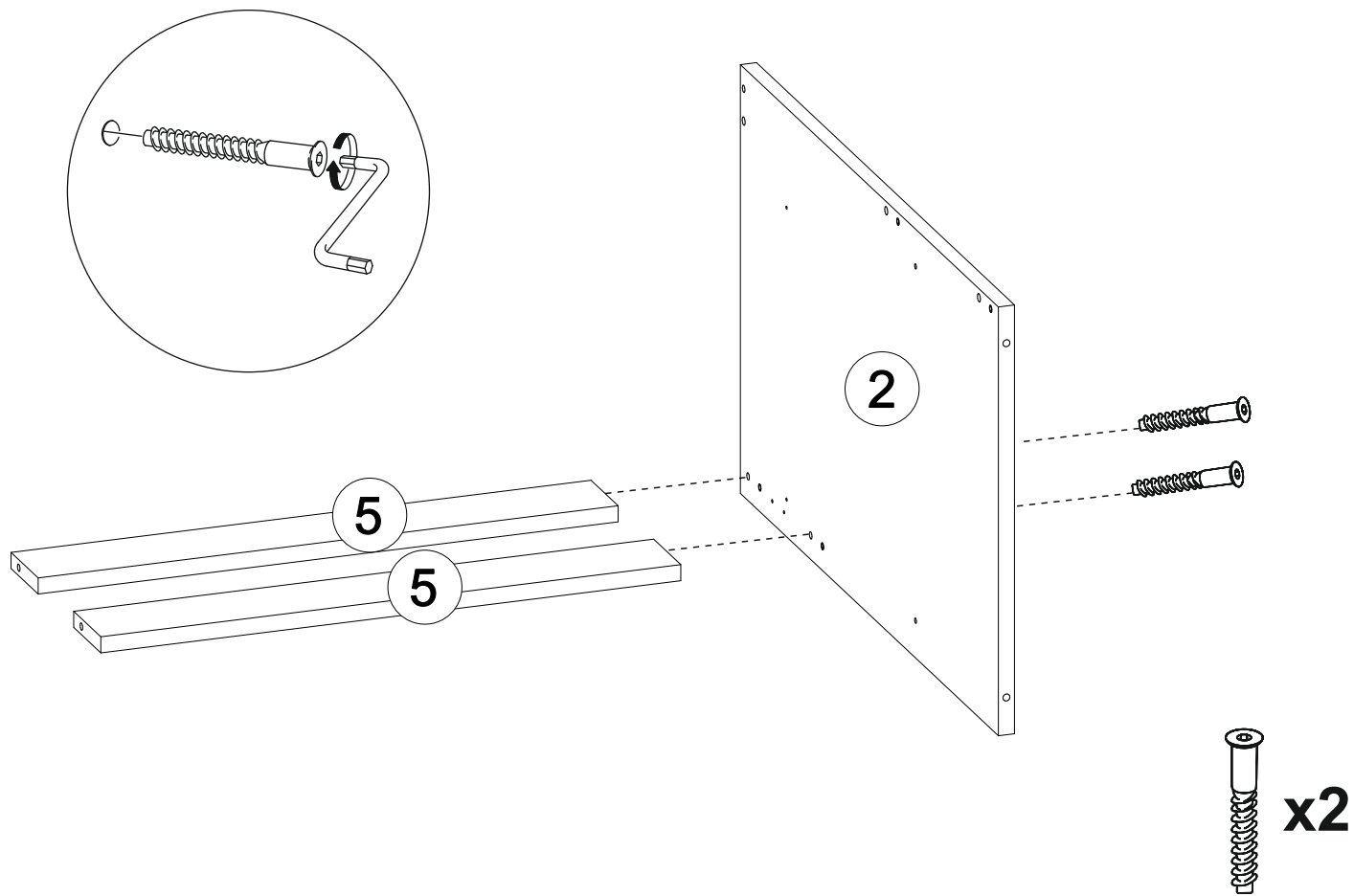

4

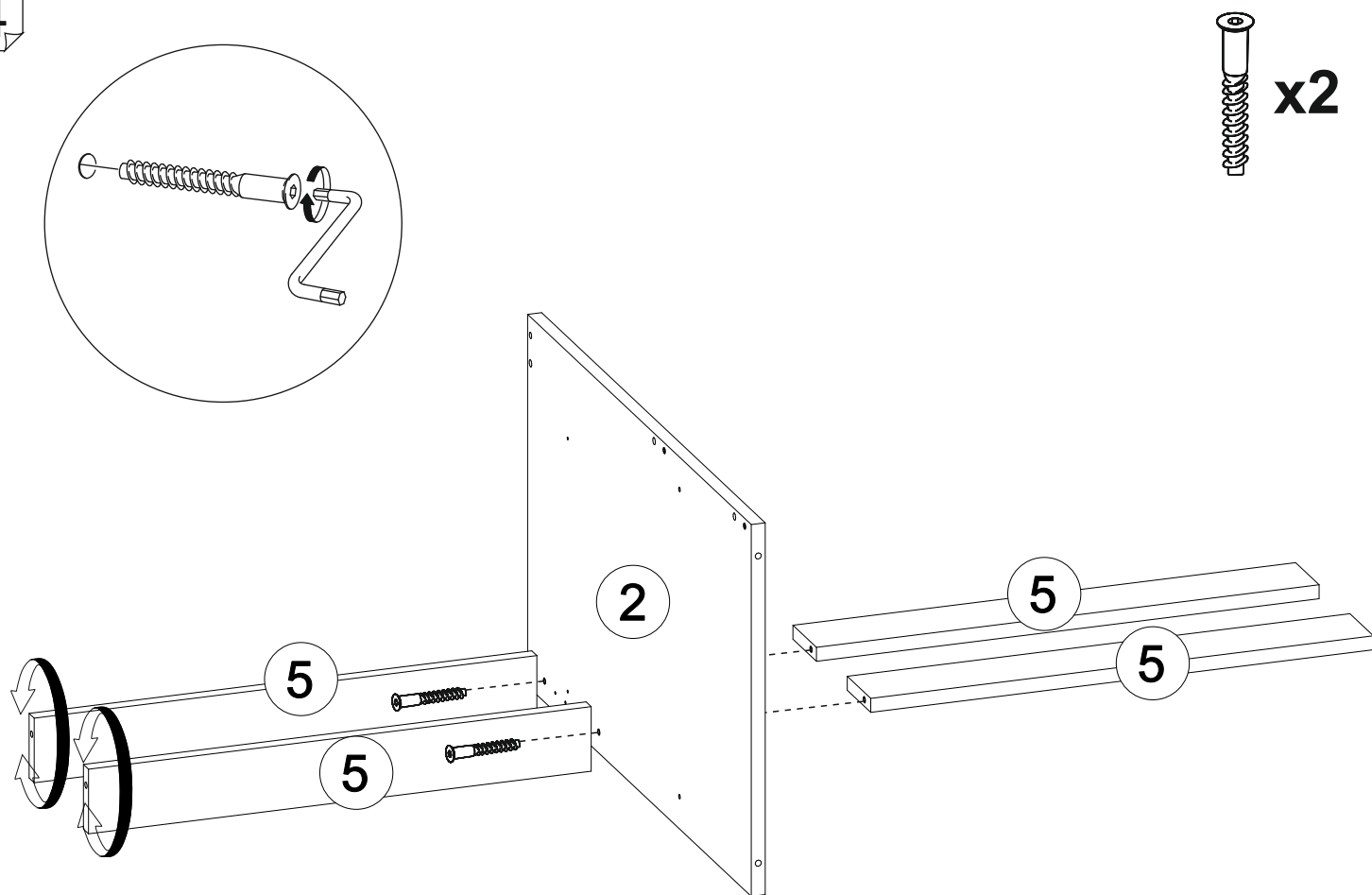

5

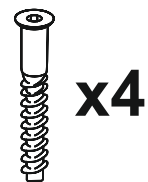
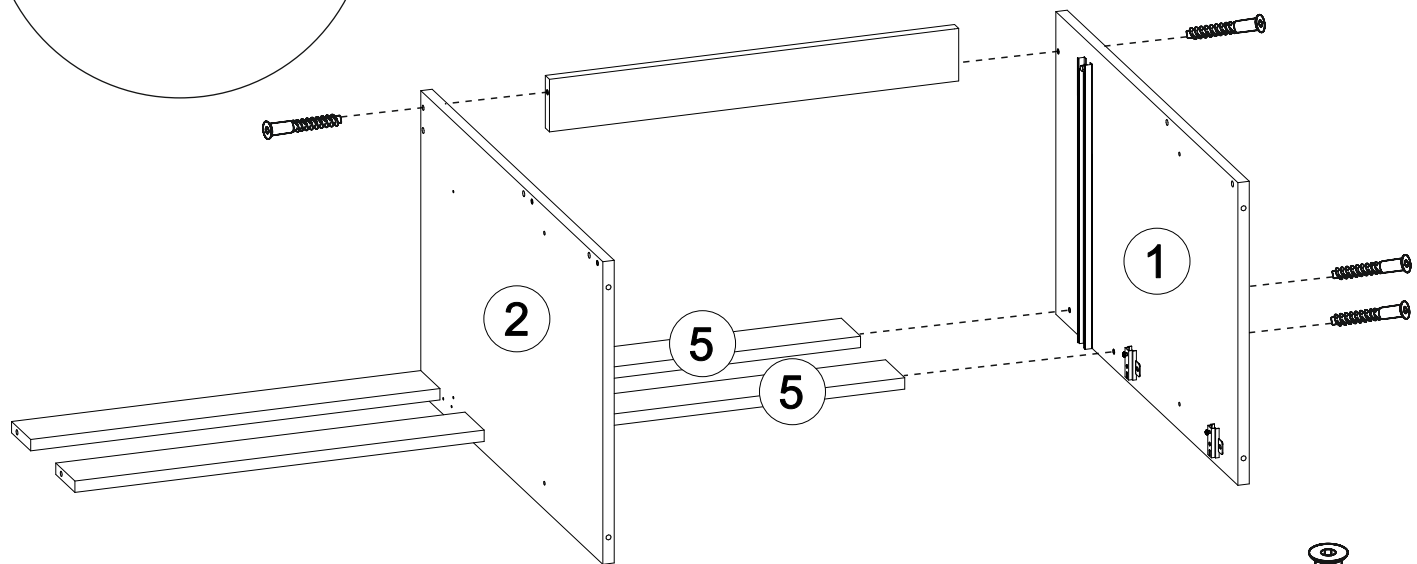
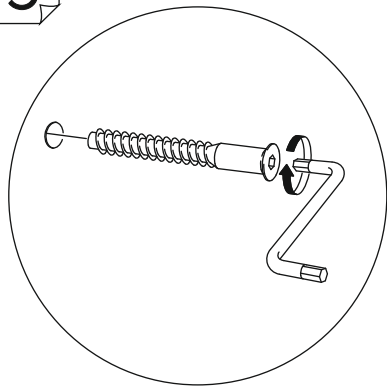

6

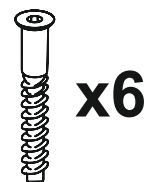
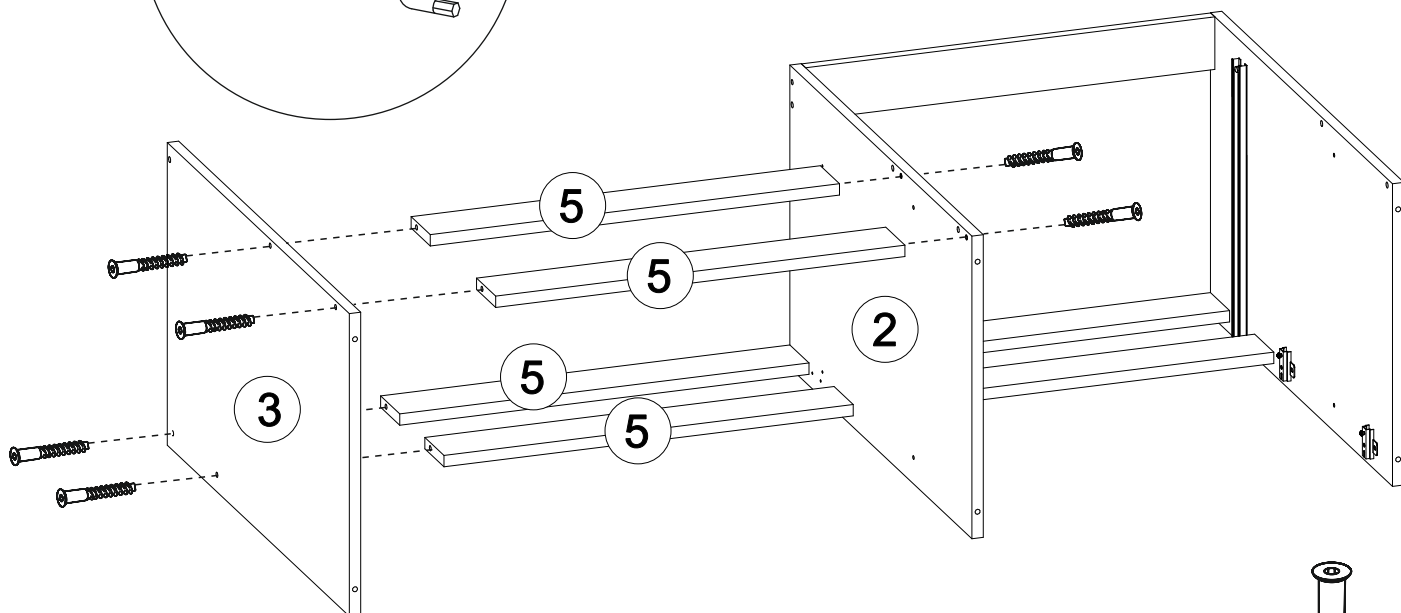
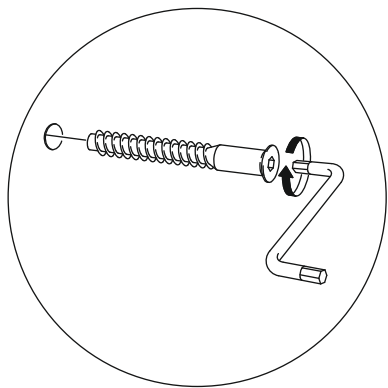

7

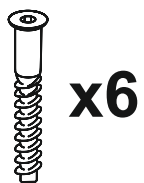
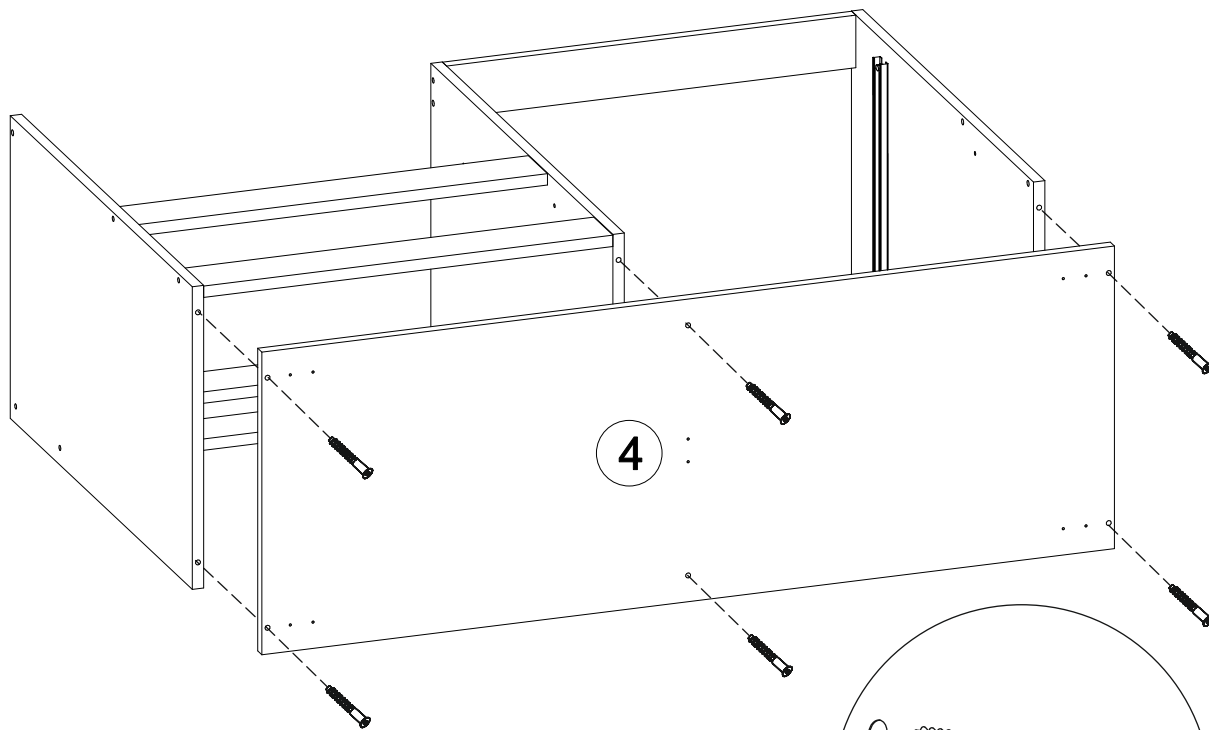

8

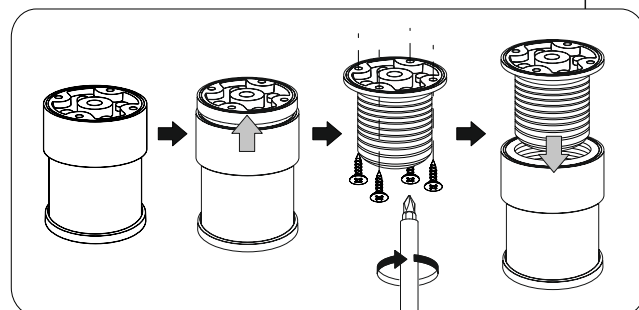
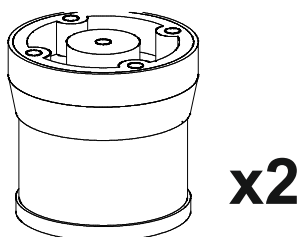
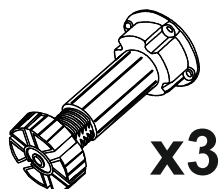
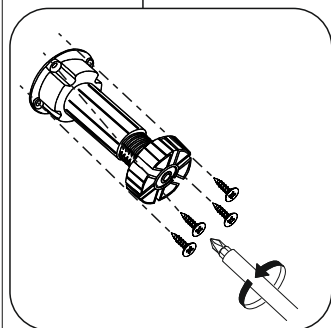
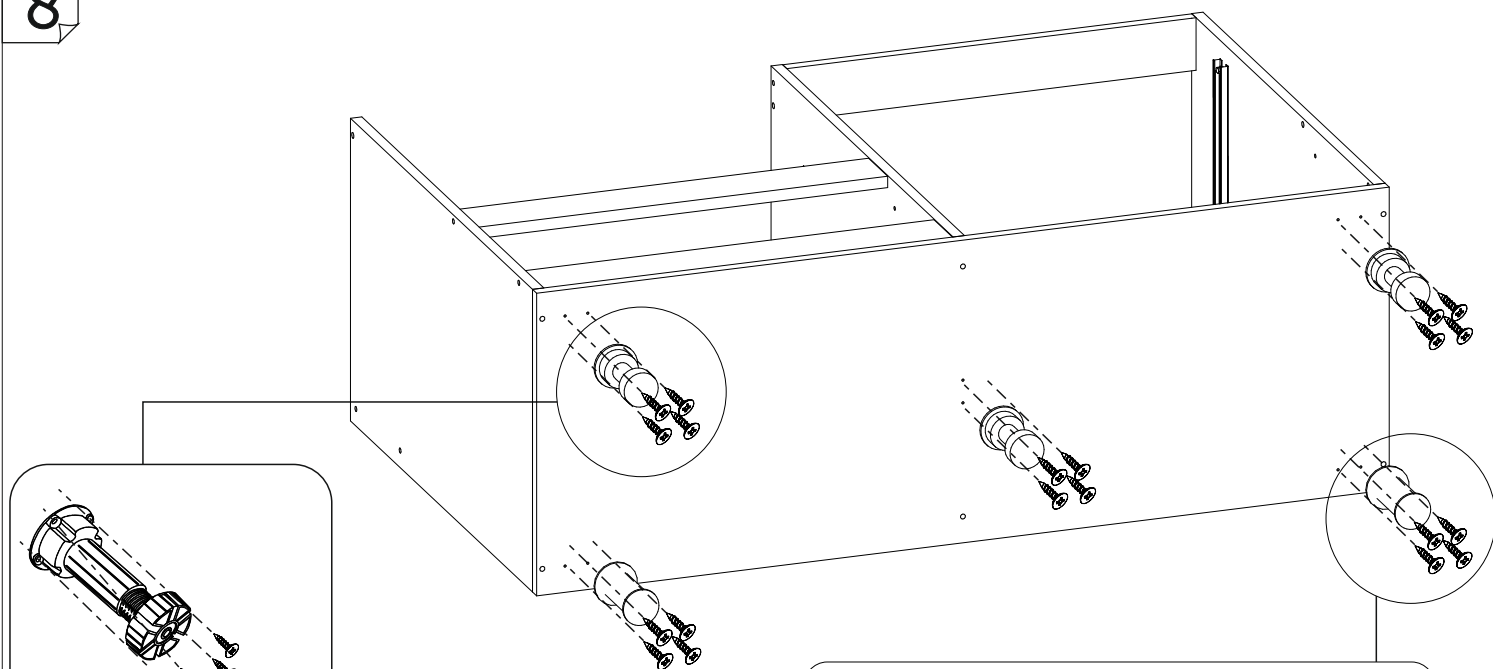

9

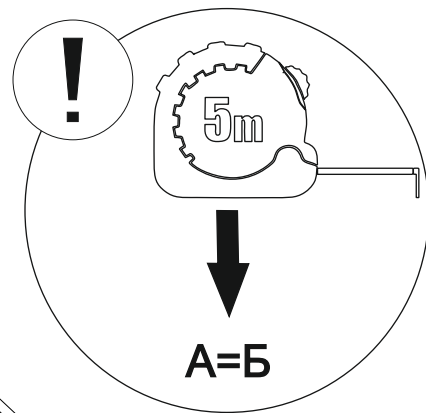
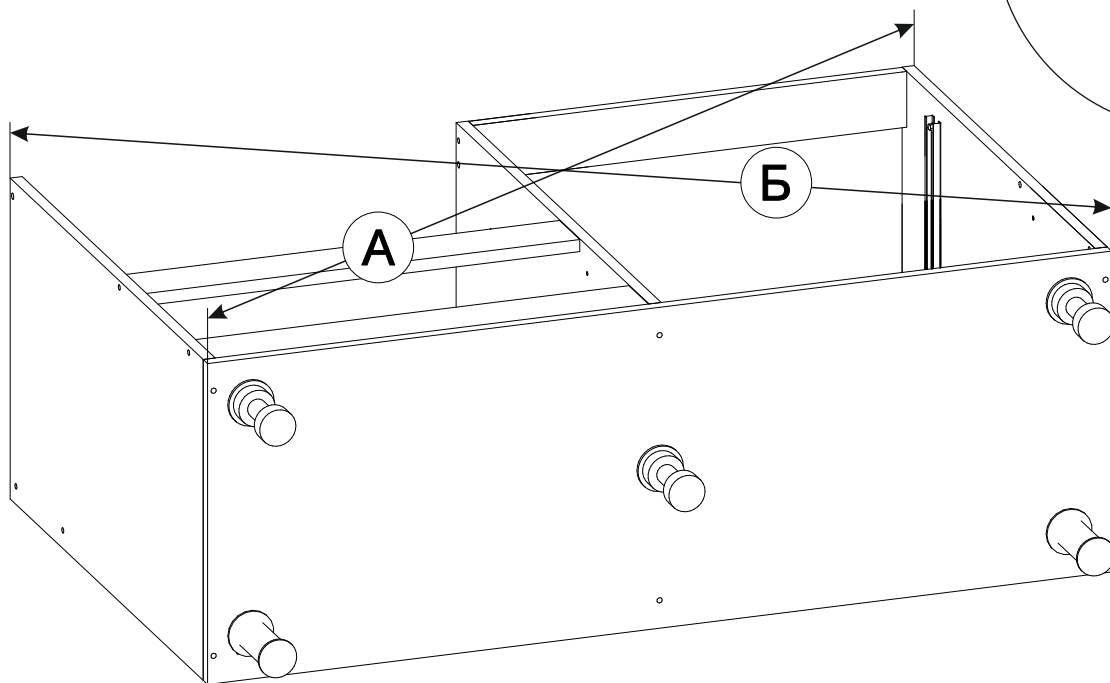

10

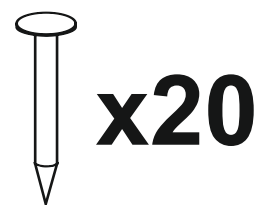
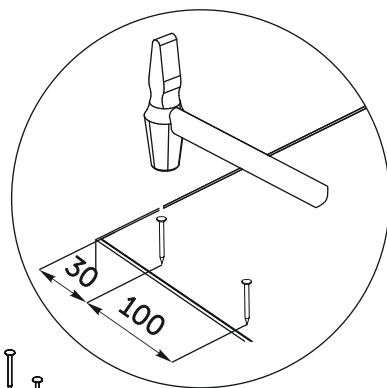
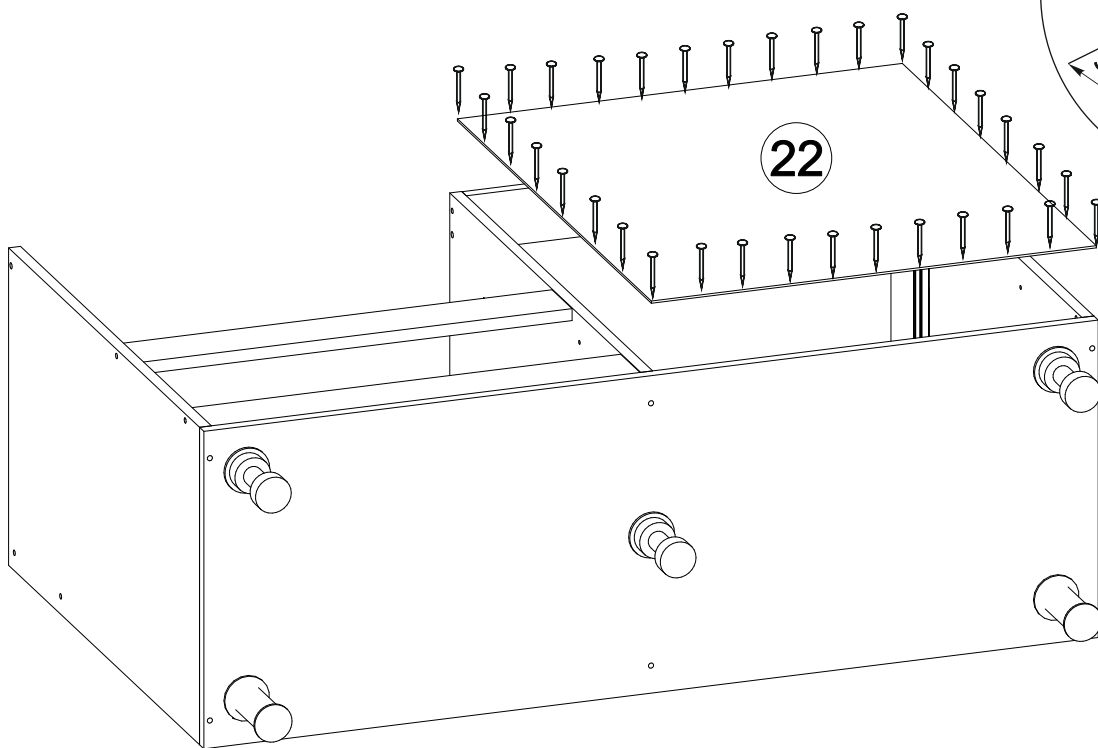

11

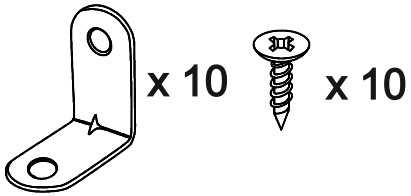
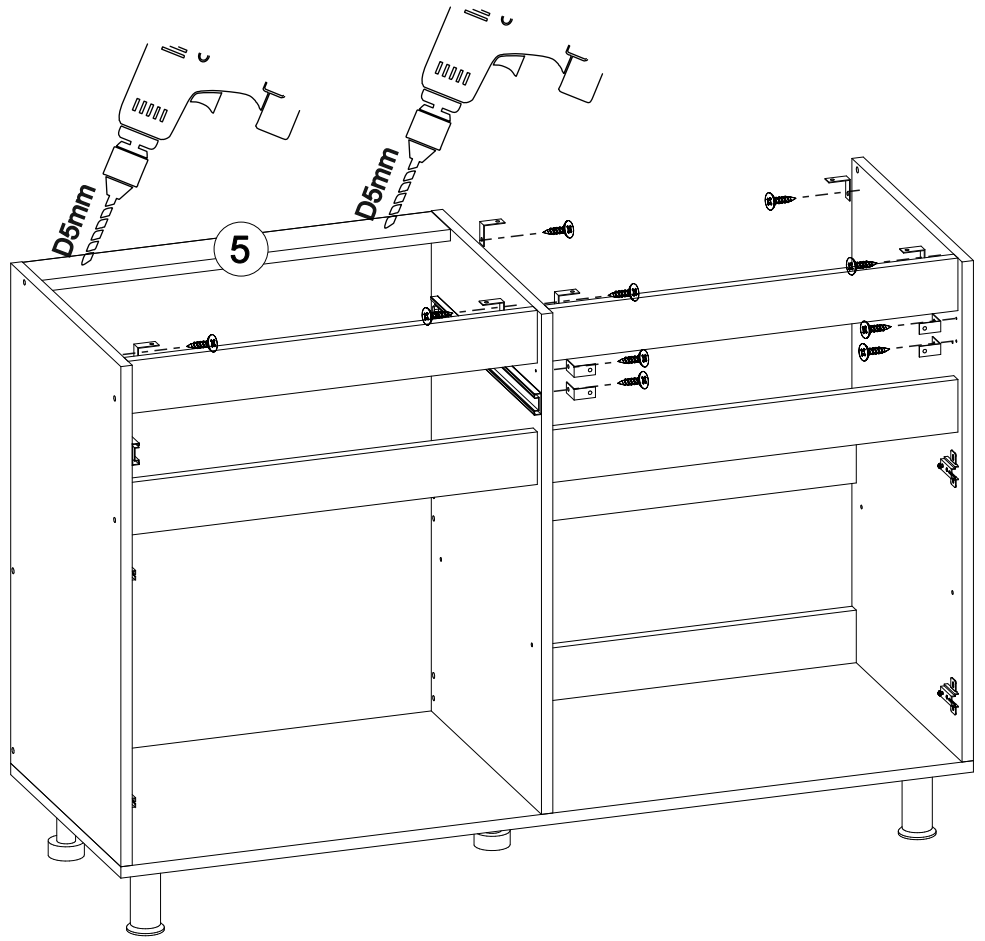
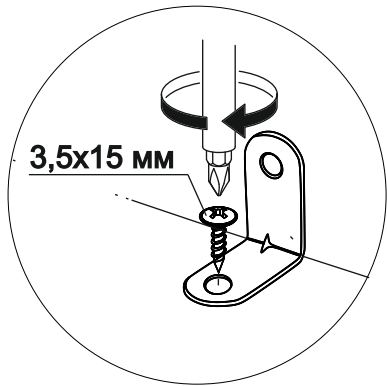

12

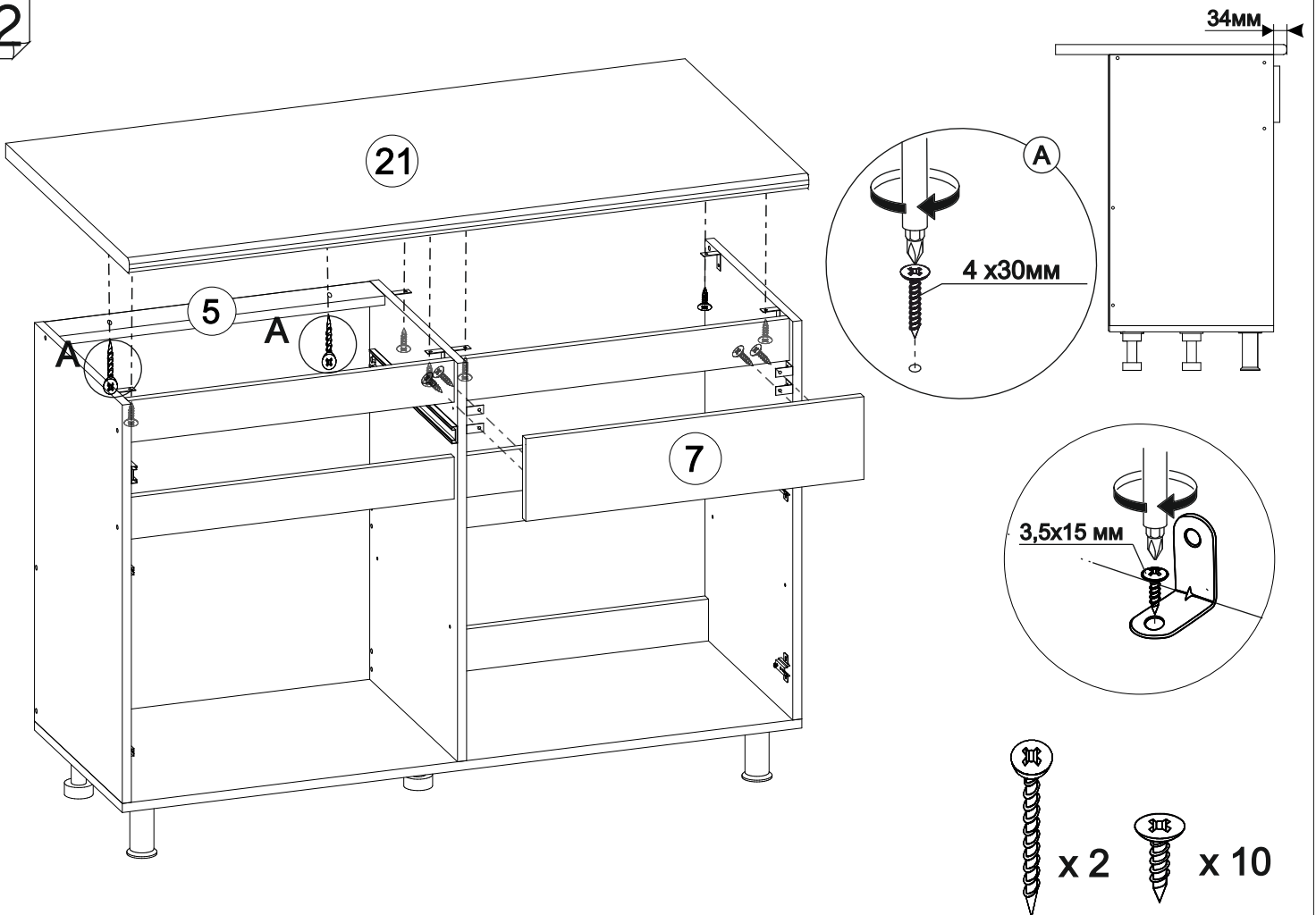

13

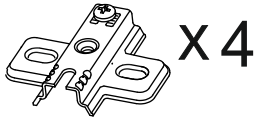
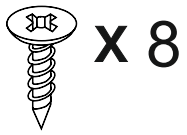
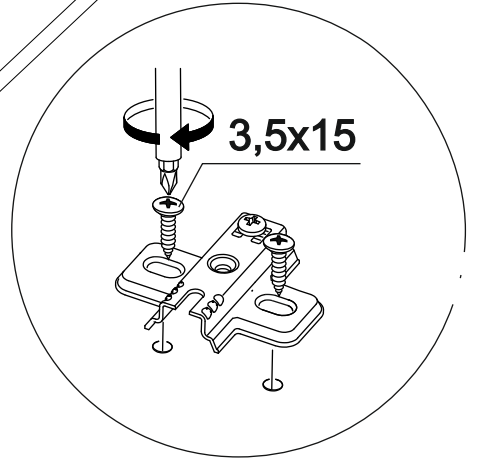
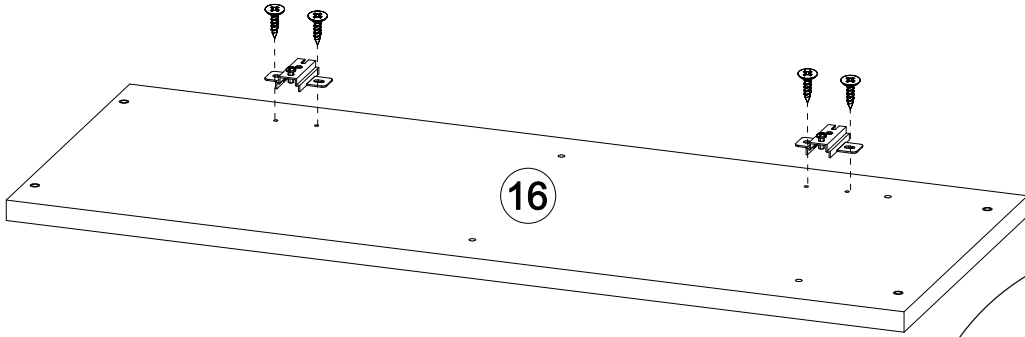
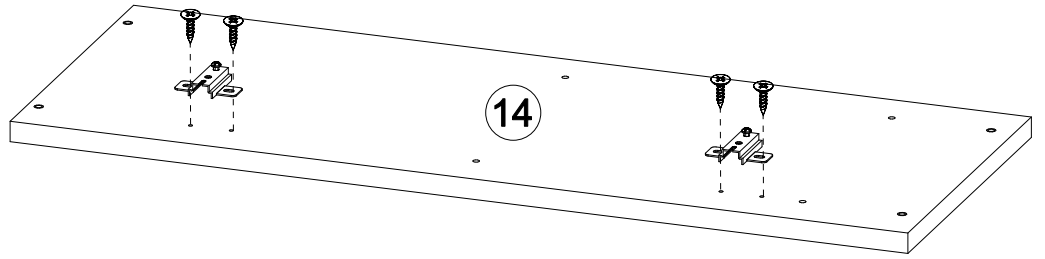

14

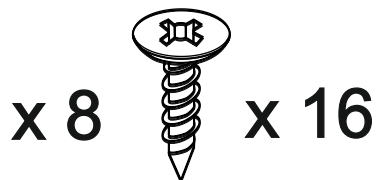
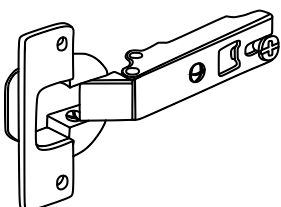
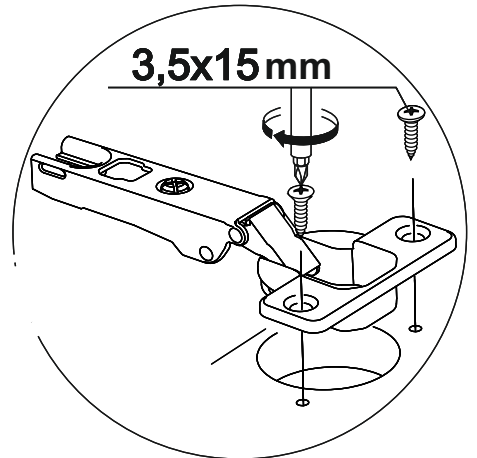
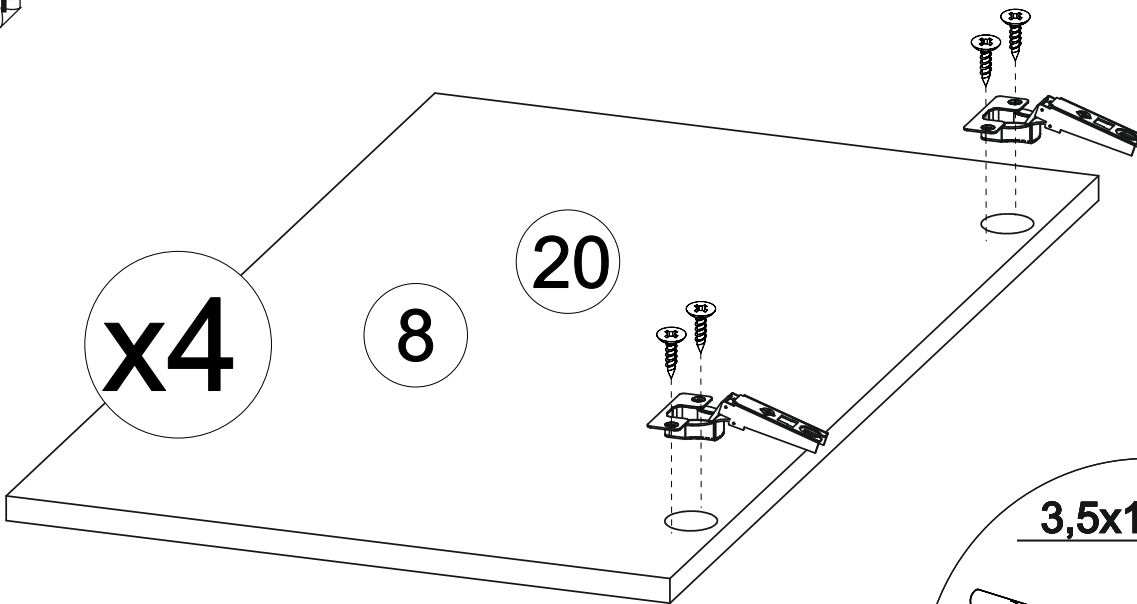

15

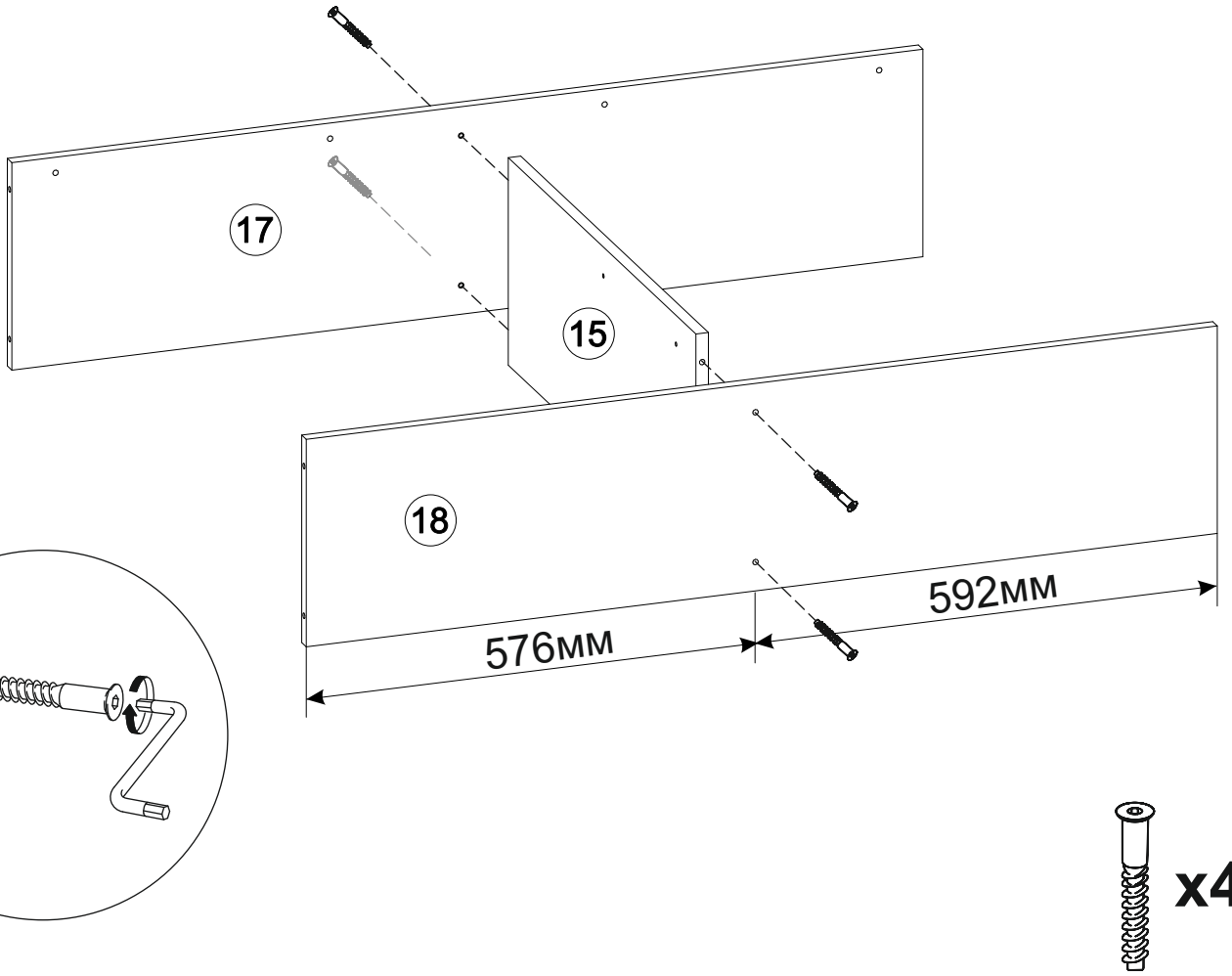

16

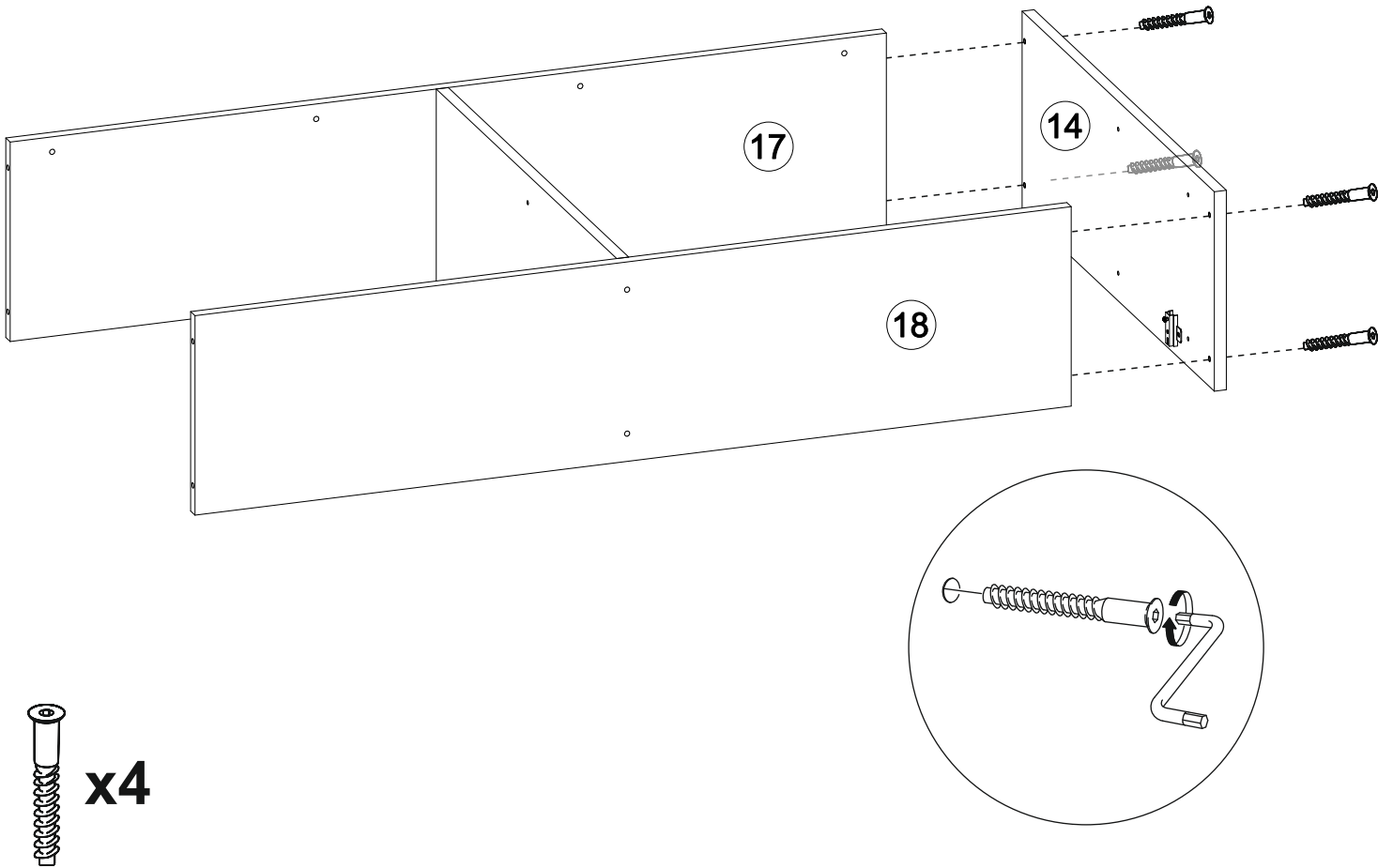

17

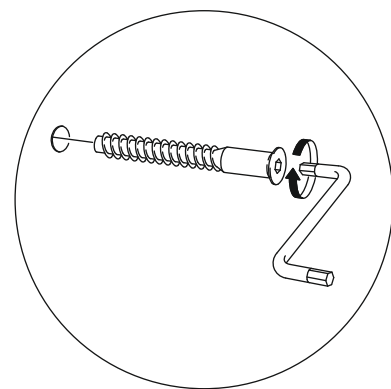
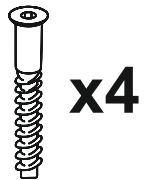
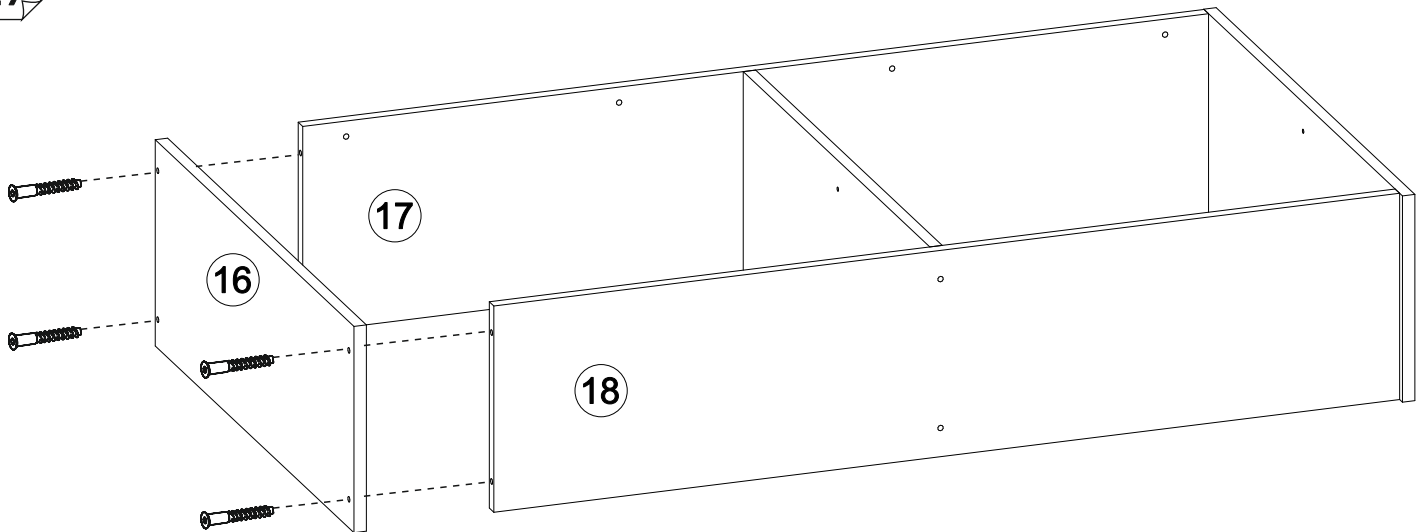

18

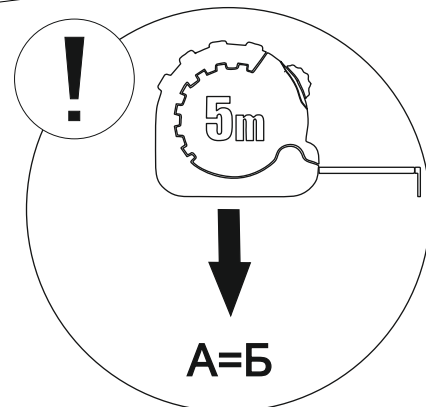
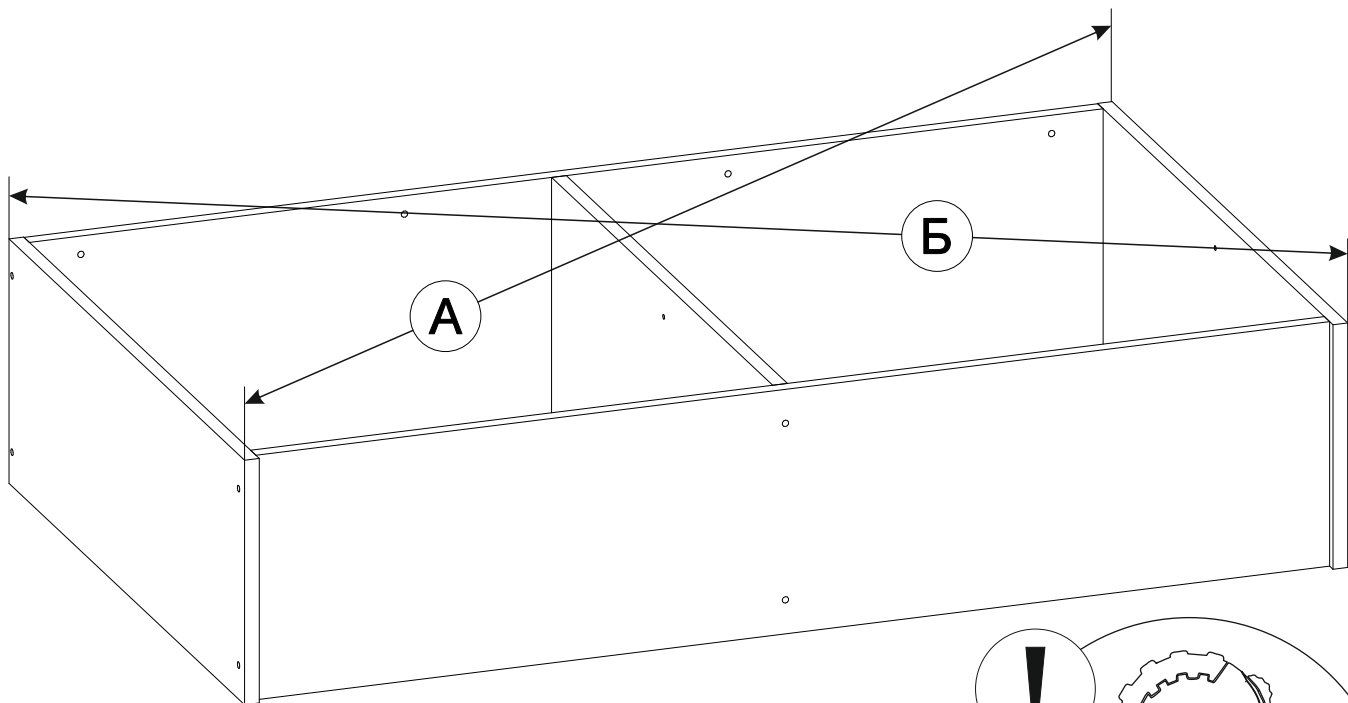

19

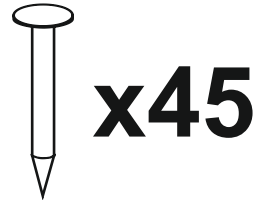
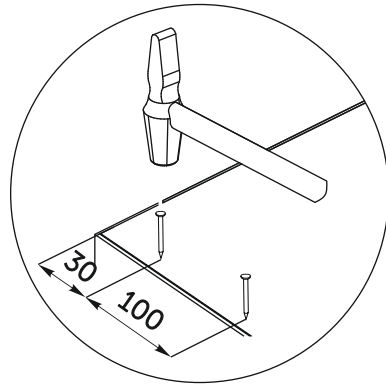
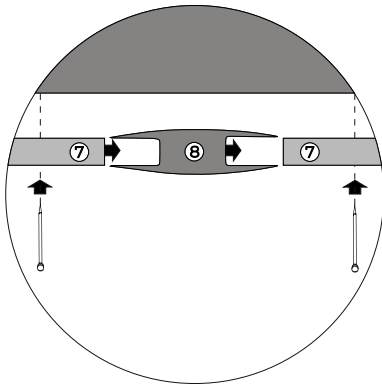
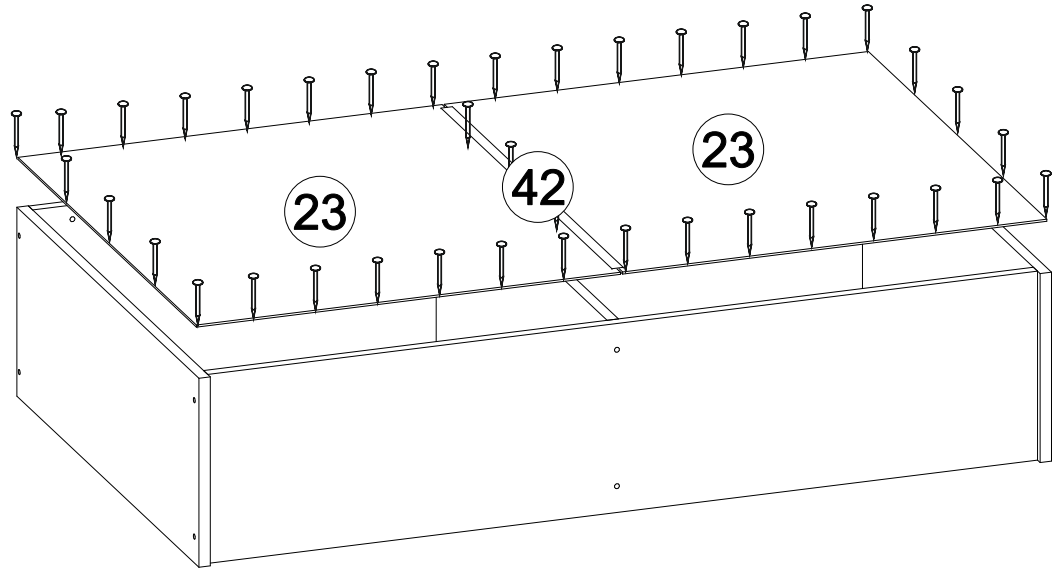

20

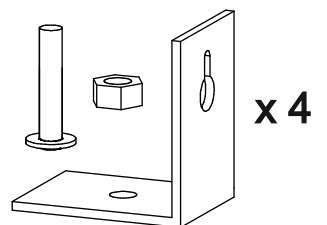
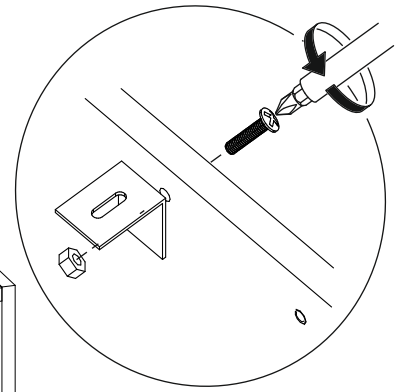
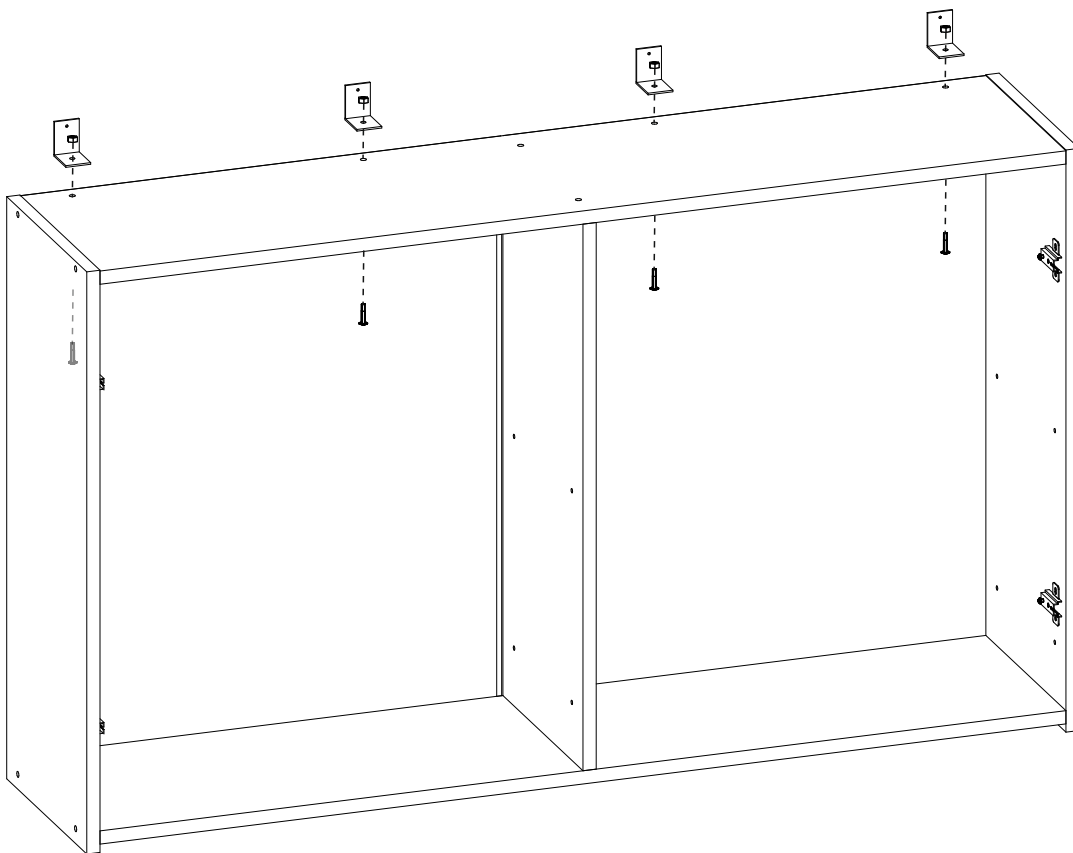

21

2150MM

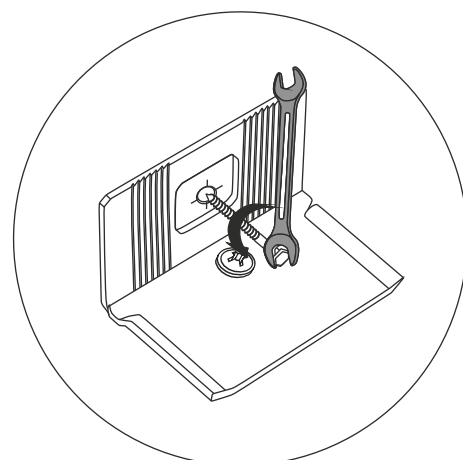
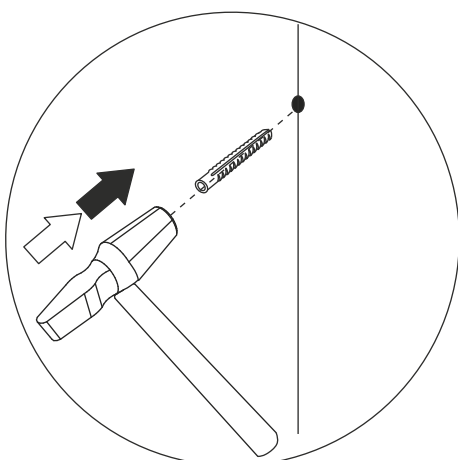
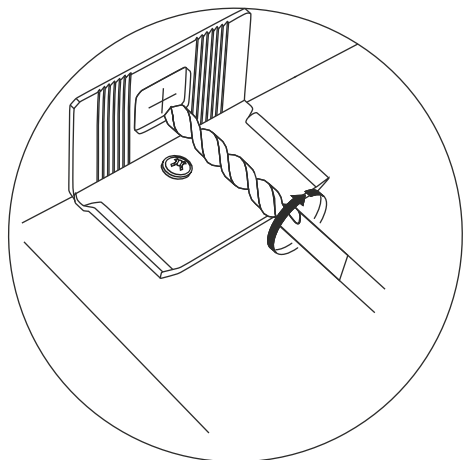
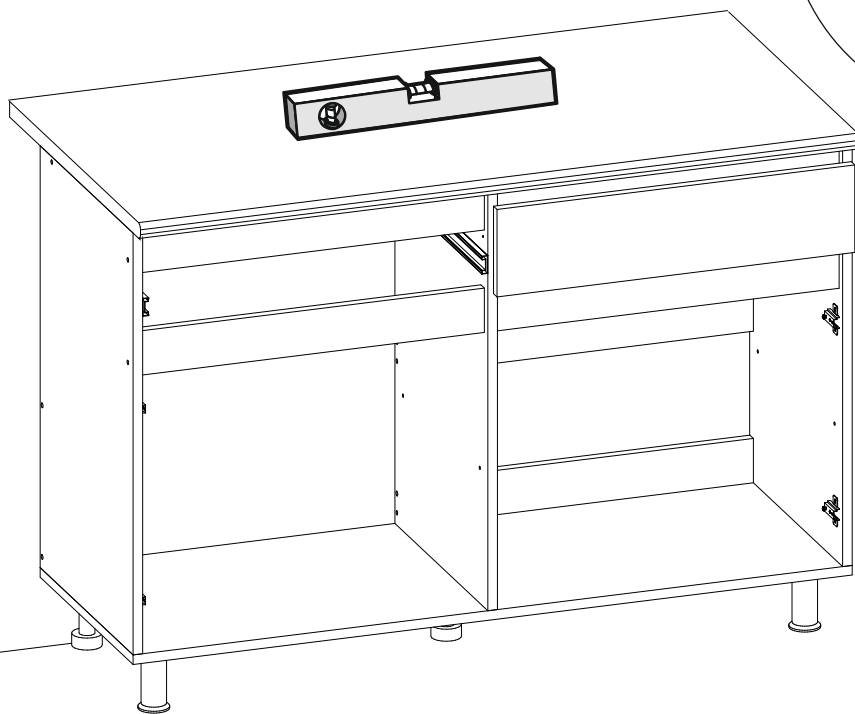
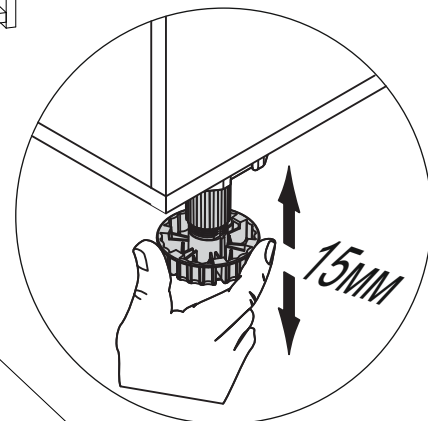
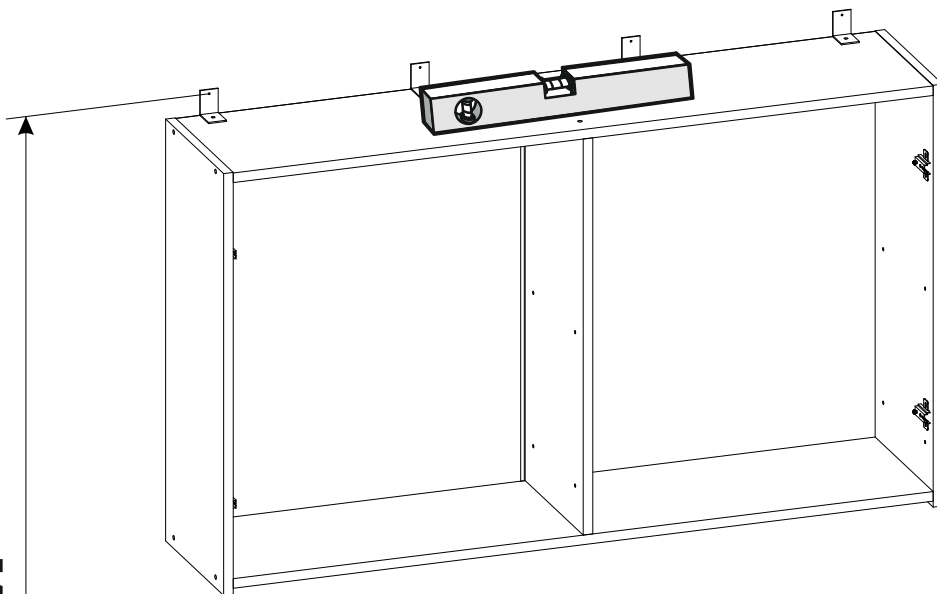

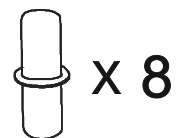
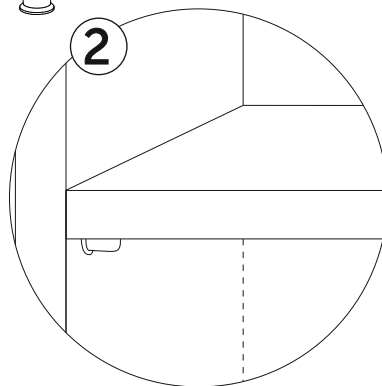
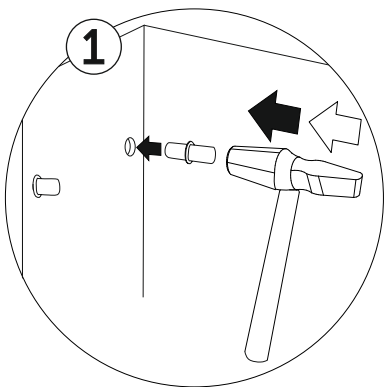
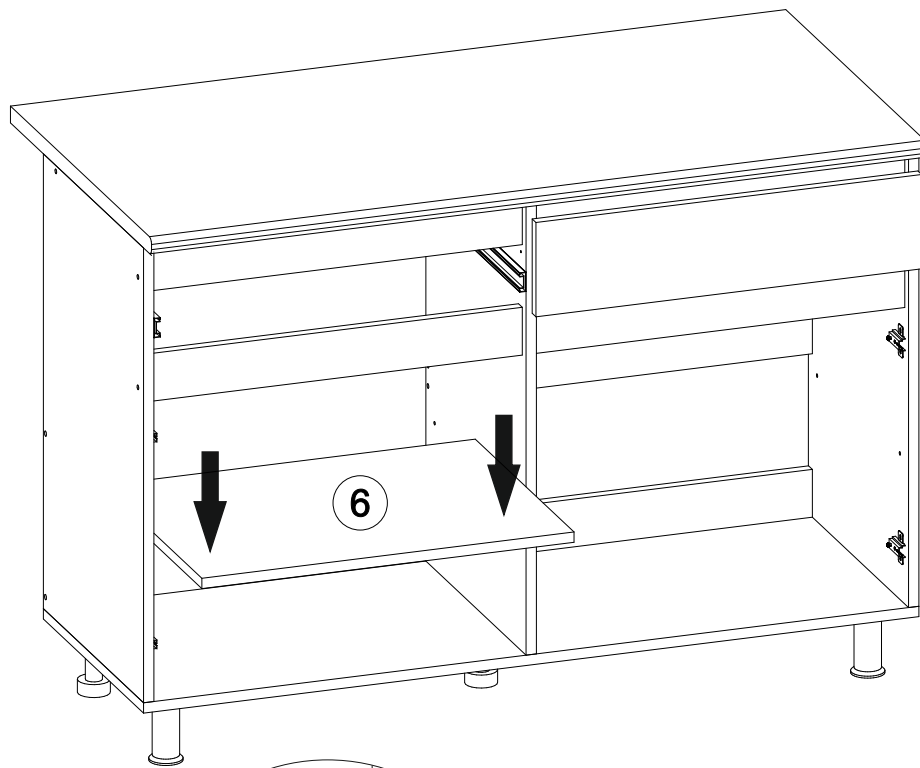
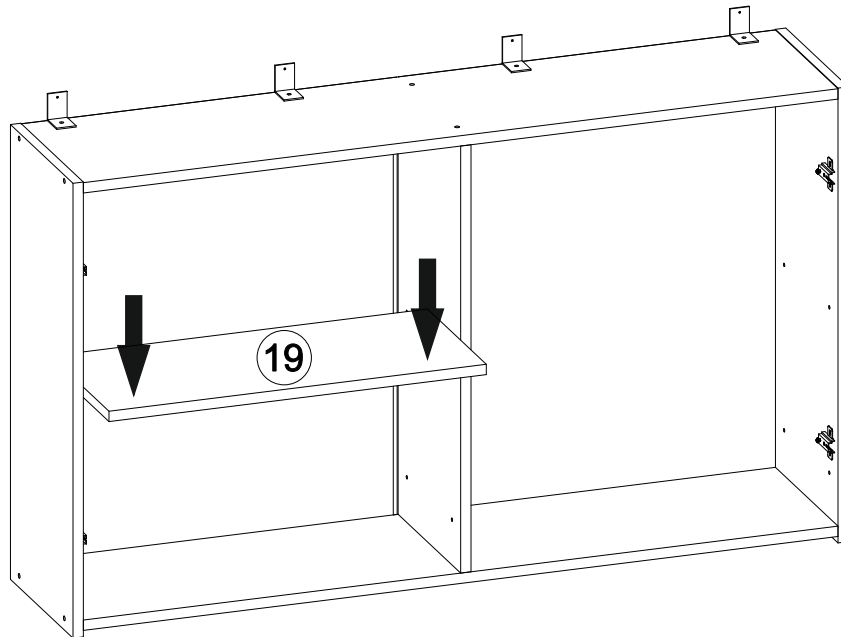

23

# Расположение ящика справа

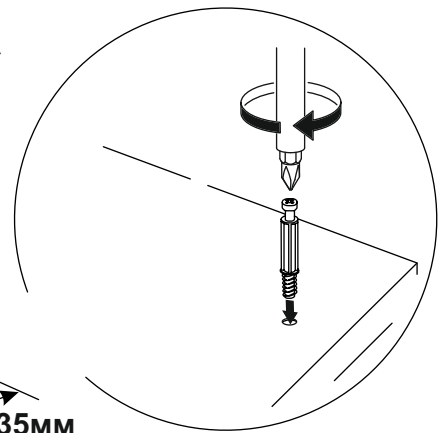
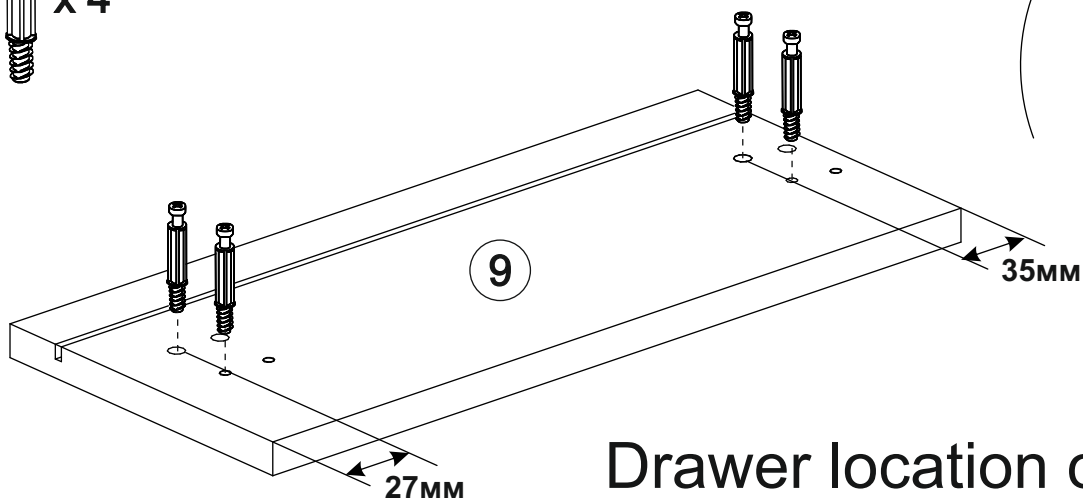
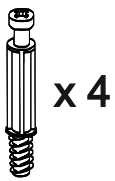

Drawer location on the right

24

# Drawer location on the left

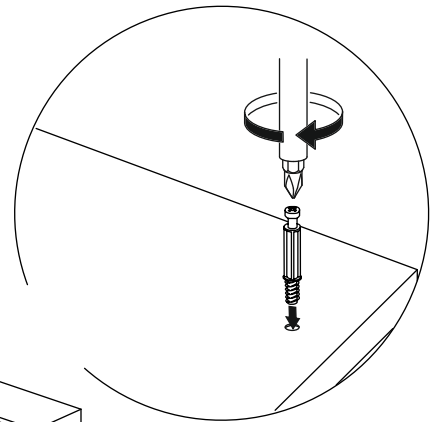
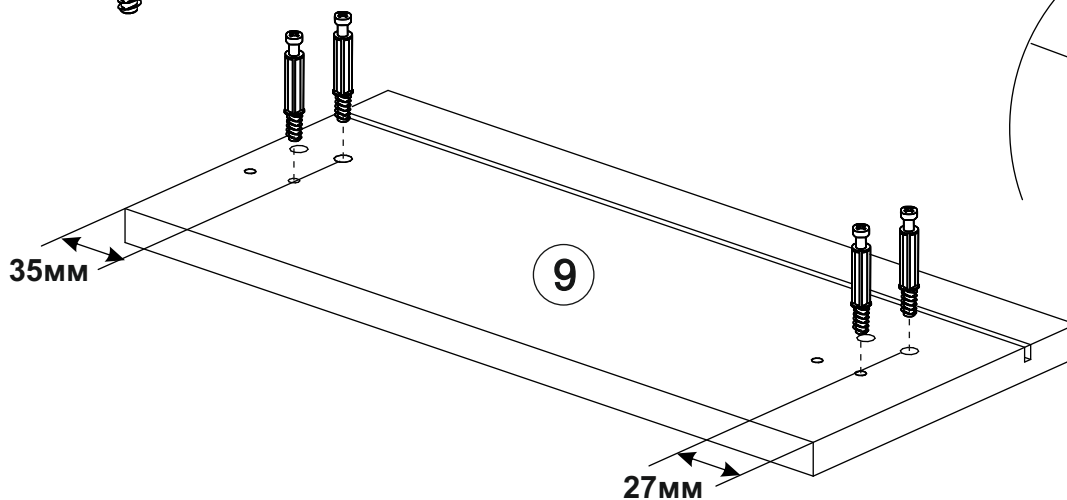
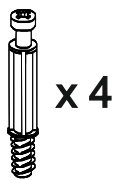

Расположение ящиков слева

25

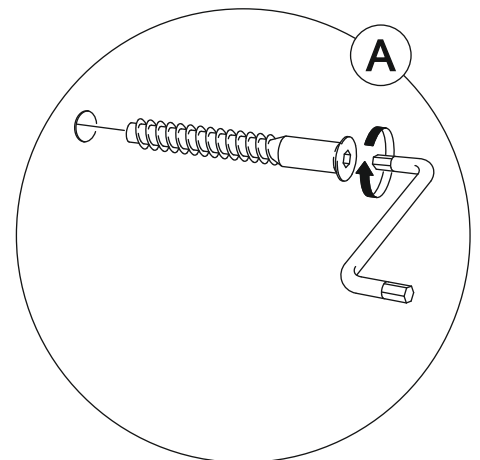
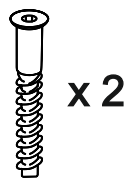
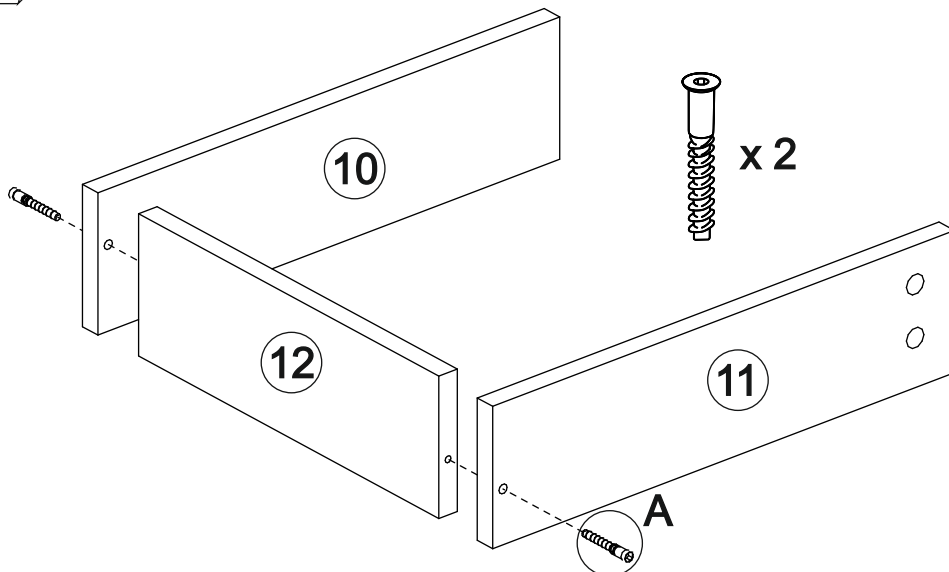

26

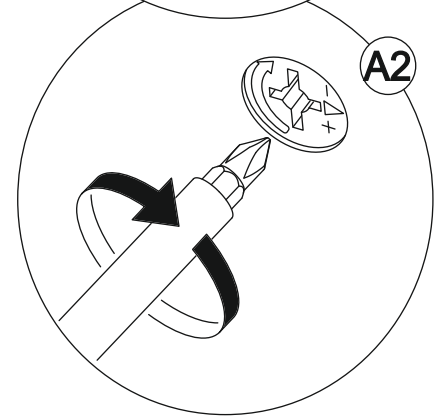
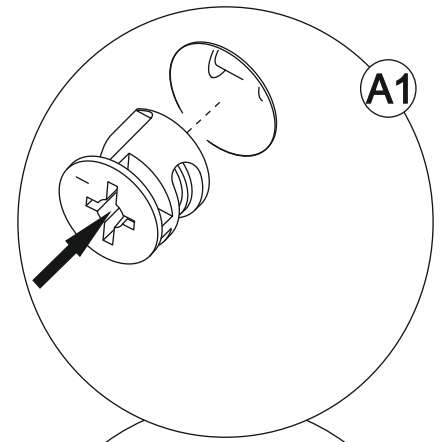
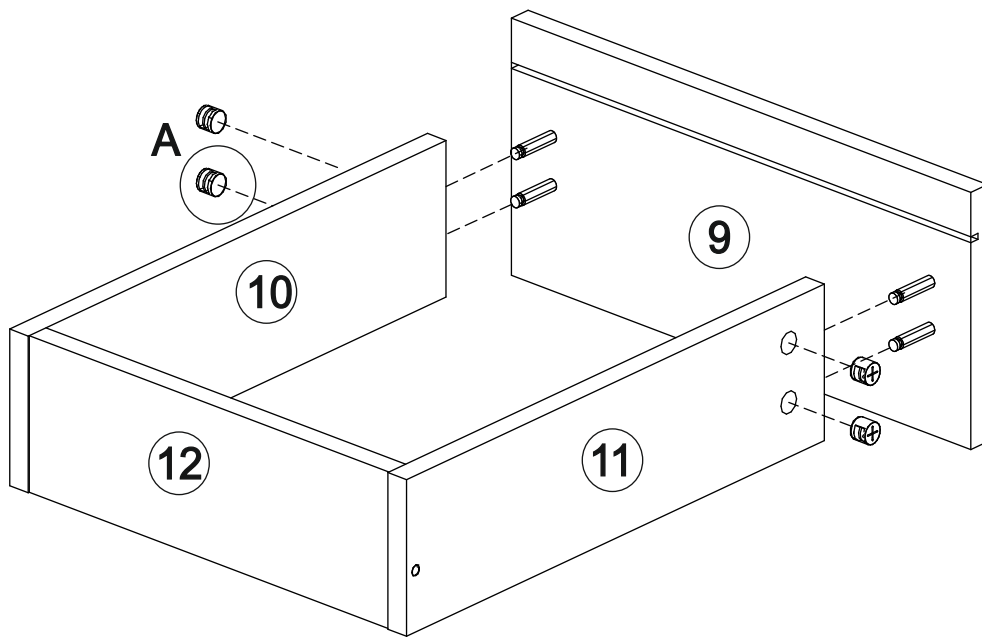

27

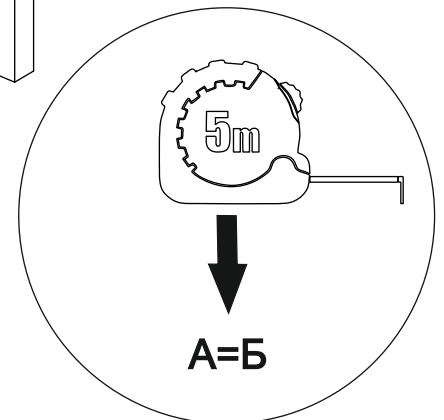
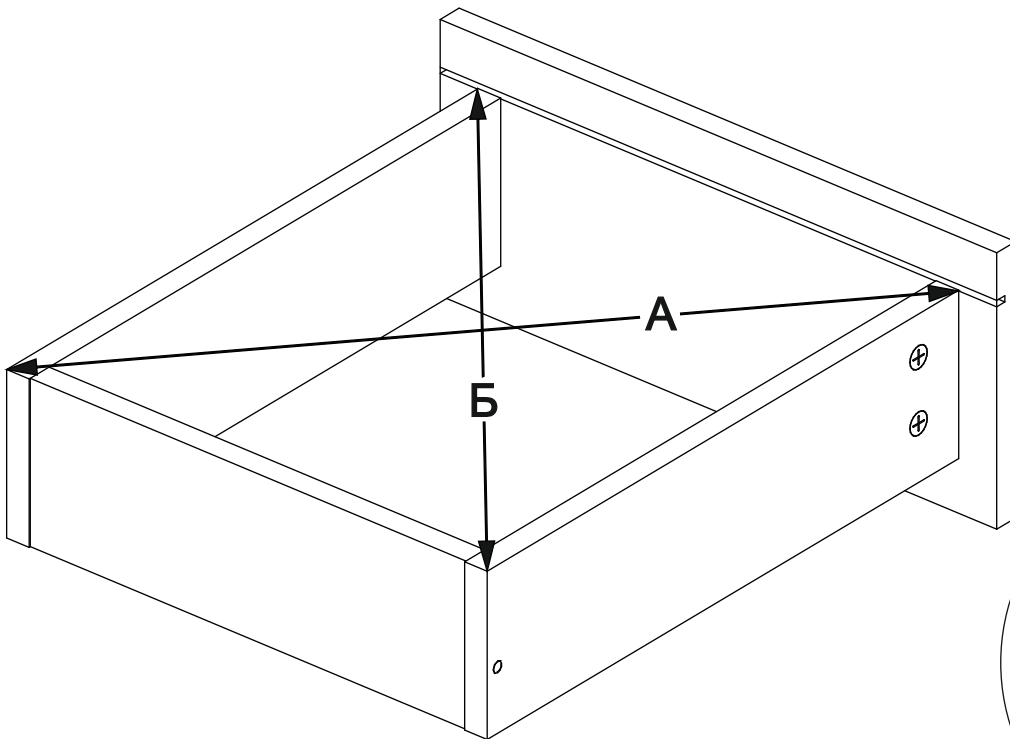

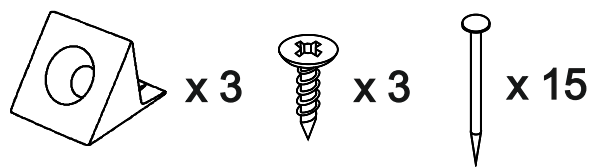
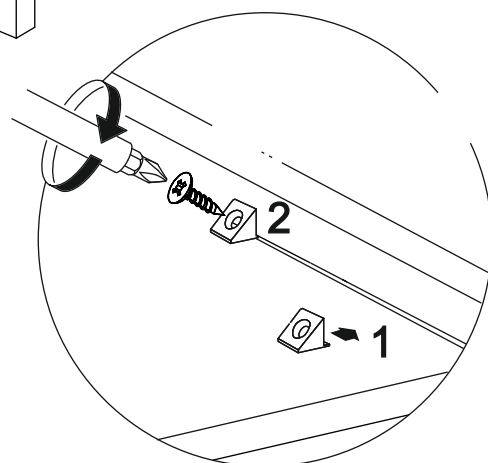
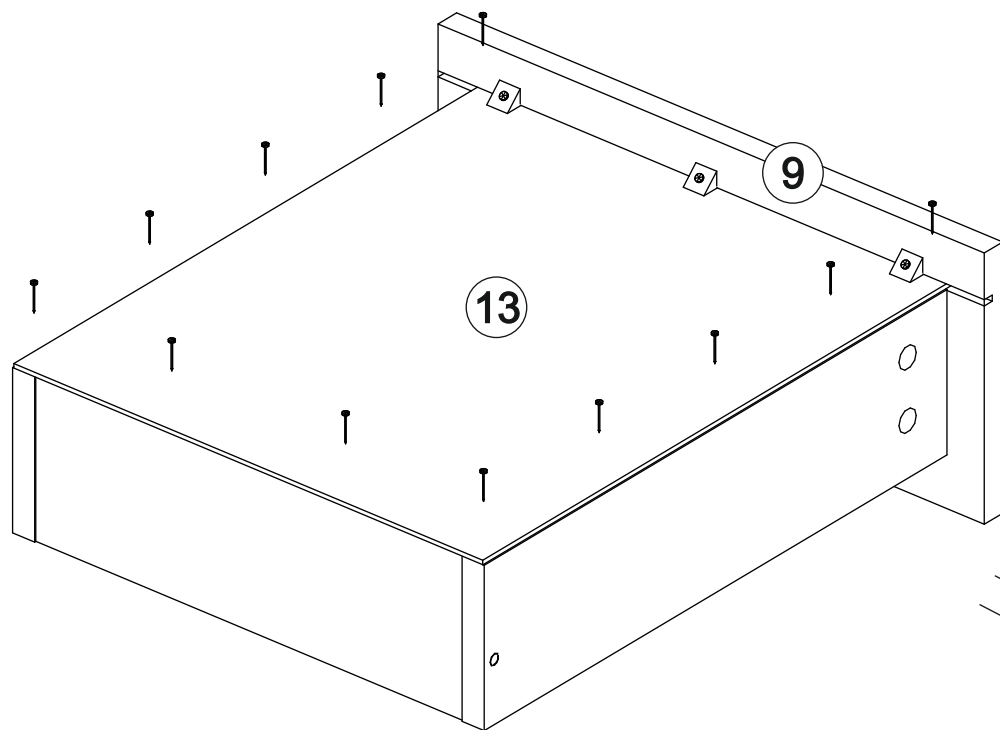
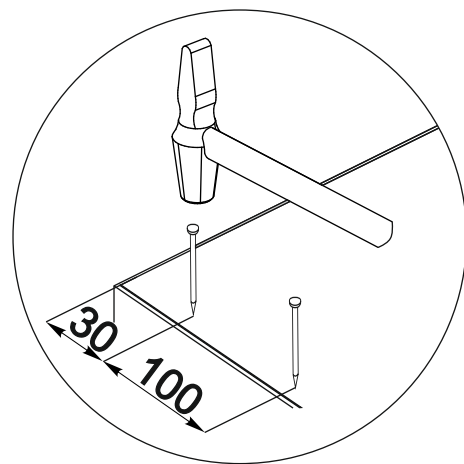
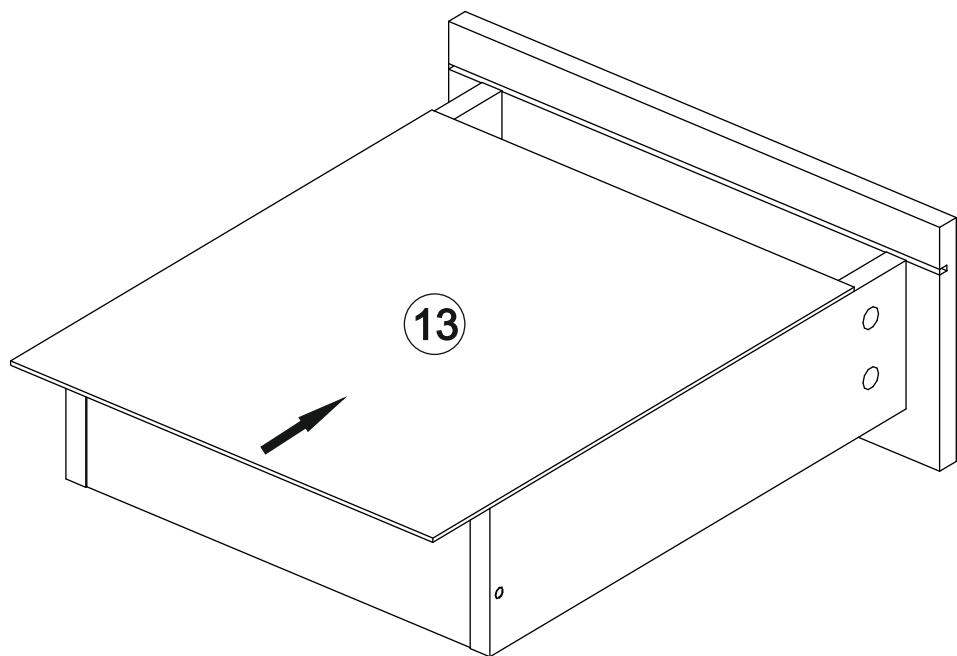

29

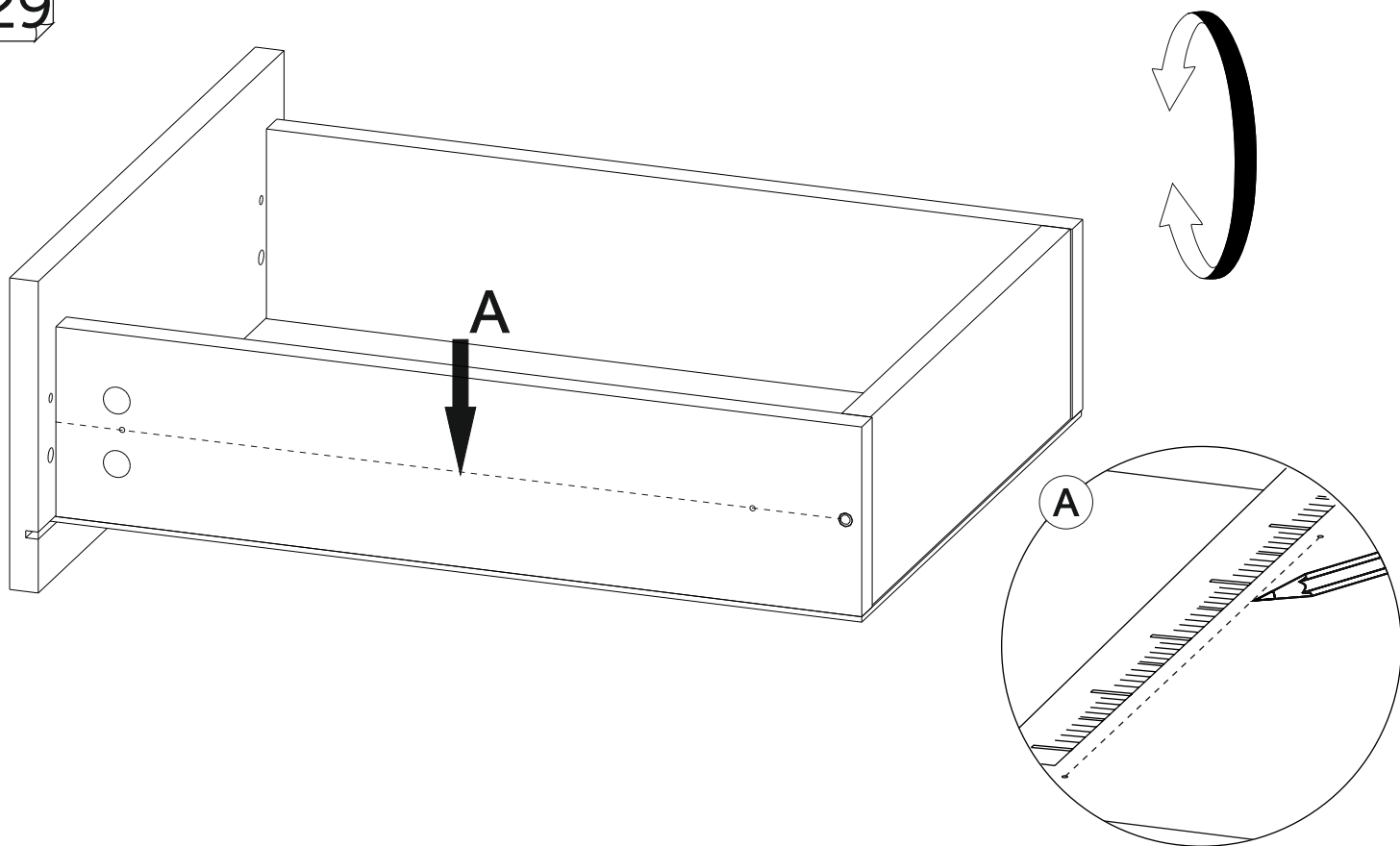

30

