

Selection diagram

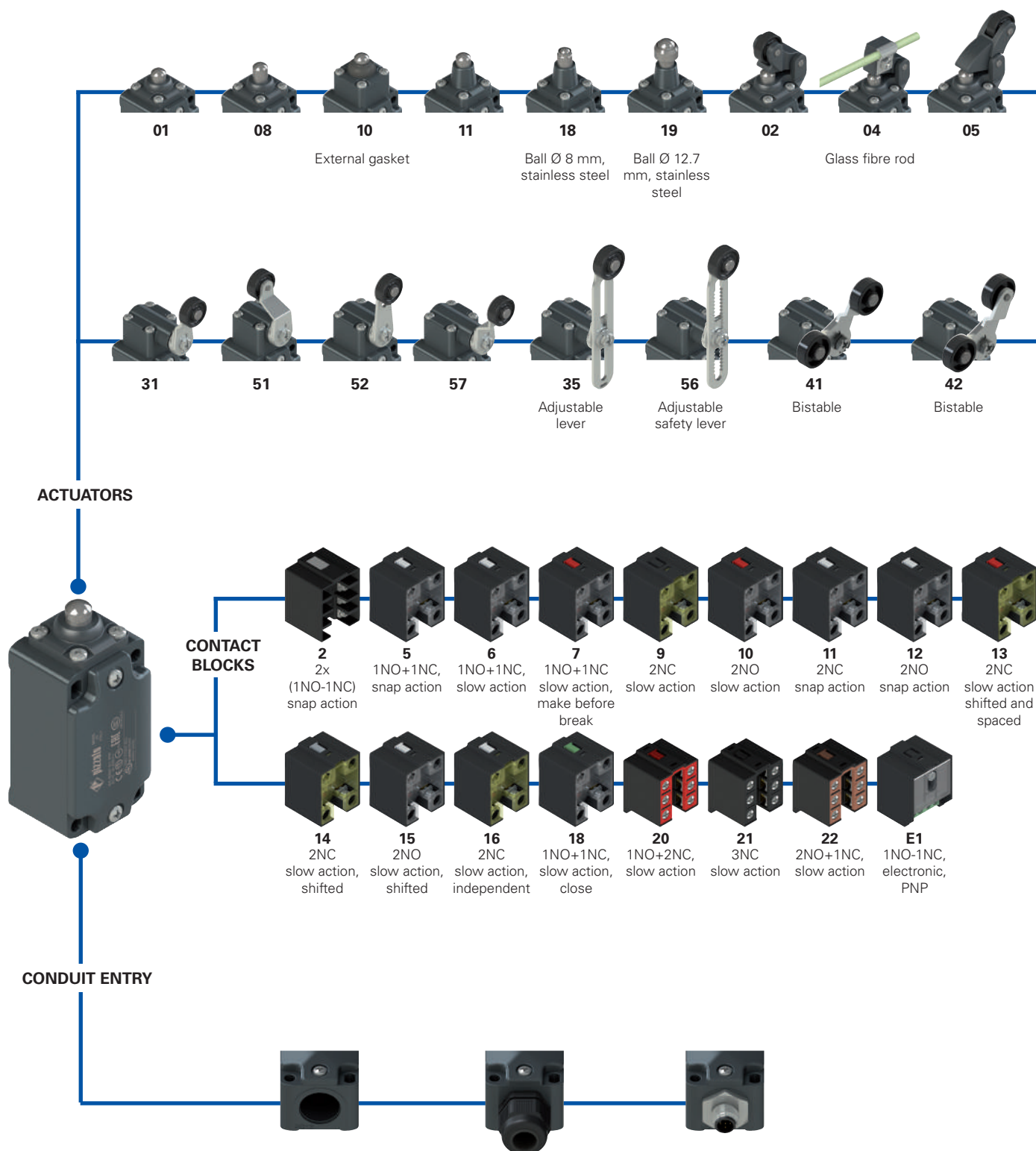

Threaded conduit entry	
M2	M20x1.5 (standard) PG 13.5

With cable gland	
K23	for cables Ø 6 ... 12 mm
K27	for cables Ø 3 ... 7 mm

With M12 metal connector	
K40	8-pole
K50	5-pole

- Product options
- Sold separately as accessory

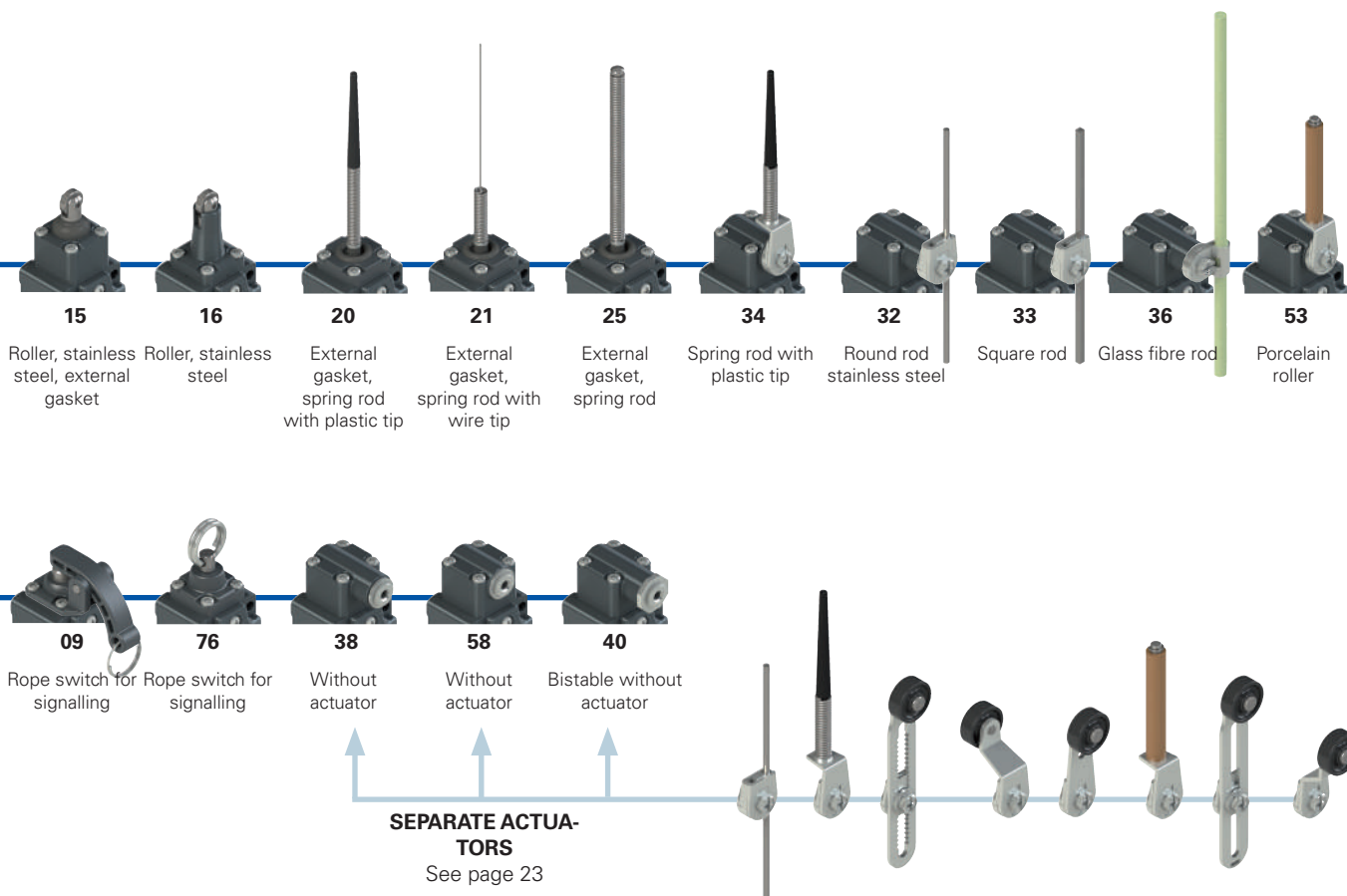
Code structure
Attention! The feasibility of a code number does not mean the effective availability of a product. Please contact our sales office.

article
options
options
FD 502-GM2K50R24T6

Housing		Ambient temperature	
FD	metal, one conduit entry		-25°C ... +80°C (standard)
Contact block		T6	-40°C ... +80°C
5	1NO+1NC, snap action	Rollers	
6	1NO+1NC, slow action		standard roller
7	1NO+1NC, slow action, make before break	R24	stainless steel Ø 20 mm (for actuators 02, 05, 31, 35, 51, 52, 56, 57)
...	R25	technopolymer, Ø 35 mm (for actuators 31, 35, 51, 52, 56, 57)
Actuators		R5	rubber, Ø 40 mm (for actuators 31, 35, 51, 52, 56, 57)
01	short plunger	R26	rubber, Ø 50 mm (for actuators 31, 35, 51, 52, 56, 57)
02	roller lever	R27	rubber, protruding, Ø 50 mm (for actuators 35 and 56)
05	angled lever with roller	Pre-installed cable glands or connectors	
...		no cable gland or connector (standard)
Contact type		K23	cable gland for cables Ø 6 ... 12 mm
	silver contacts (standard)	K27	cable gland for cables Ø 3 ... 7°mm
G	silver contacts, 1 µm gold coating	K40	M12 metal connector, 8-pole
G1	silver contacts, 2.5 µm gold coating (not for contact block 2, 20, 21, 22)	K50	M12 metal connector, 5-pole
Threaded conduit entry		For the complete list of possible combinations please contact our technical department.	
M2	M20x1.5 (standard)		
	PG 13.5		



Main features

- Metal housing, one conduit entry
- Protection degree IP67
- 17 contact blocks available
- 29 actuators available
- Versions with M12 connector
- Versions with gold-plated silver contacts

Technical data

Housing

Metal housing, powder-coated
 One threaded conduit entry: M20x1.5 (standard)
 Protection degree acc. to EN 60529: IP67 with cable gland of equal or higher protection degree

General data

Ambient temperature: -25°C ... +80°C (standard)
 -40°C ... +80°C (T6 option)
 Max. actuation frequency: 3600 operating cycles/hour
 Mechanical endurance: 20 million operating cycles
 Mounting position: any
 Safety parameter B_{10D} : 40,000,000 for NC contacts
 Mechanical interlock, not coded: type 1 acc. to EN ISO 14119
 Tightening torques for installation: see page 227
 Wire cross-sections and wire stripping lengths: see page 247

In compliance with standards:

IEC 60947-5-1, EN 60947-5-1, EN 60947-1, EN 50041, IEC 60204-1, EN 60204-1, EN ISO 14119, EN ISO 12100, IEC 60529, EN 60529, EN IEC 63000, UL 508, CSA 22.2 No.14.

Approvals:

IEC 60947-5-1, UL 508, CSA 22.2 No.14, GB/T14048.5

Compliance with the requirements of:

Low Voltage Directive 2014/35/EU, EMC Directive 2014/30/EU, RoHS Directive 2011/65/EU.

Positive contact opening in conformity with standards:

IEC 60947-5-1, EN 60947-5-1.

Quality marks:



IMQ approval: EG605
 UL approval: E131787
 CCC approval: 2020970305002282
 EAC approval: RU C-IT.YT03.B.00035/19

Installation for safety applications:

Use only switches marked with the symbol \ominus next to the product code. Always connect the safety circuit to the **NC contacts** (normally closed contacts: 11-12, 21-22 or 31-32) as required by **EN ISO 14119, paragraph 5.4** for specific interlock applications and **EN ISO 13849-2 tables D3** (well-tried components) and **D.8** (fault exclusions) for safety applications in general. Actuate the switch **at least up to the positive opening travel** shown in the travel diagrams on page 228. Actuate the switch **at least with the positive opening force**, reported in brackets below each article, next to the actuating force value.

⚠ If not expressly indicated in this chapter, for correct installation and utilization of all articles see the instructions given on pages 225 to 240.

	Electrical data	Utilization category
without connector	Thermal current (I _{th}):	10 A
	Rated insulation voltage (U _i):	500 Vac 600 Vdc 400 Vac 500 Vdc (contact blocks 2, 11, 12, 20, 21, 22)
	Rated impulse withstand voltage (U _{imp}):	6 kV 4 kV (contact blocks 20, 21, 22)
	Conditional short circuit current: Protection against short circuits: Pollution degree:	1000 A acc. to EN 60947-5-1 type aM fuse 10 A 500 V 3
with M12 connector, 5-pole	Thermal current (I _{th}):	4 A
	Rated insulation voltage (U _i):	250 Vac 300 Vdc
	Protection against short circuits: Pollution degree:	type gG fuse 4 A 500 V 3
		Alternating current: AC15 (50÷60 Hz) U _e (V) 250 400 500 I _e (A) 6 4 1 Direct current: DC13 U _e (V) 24 125 250 I _e (A) 3 0.55 0.3
with M12 connector, 8-pole	Thermal current (I _{th}):	2 A
	Rated insulation voltage (U _i):	30 Vac 36 Vdc
	Protection against short circuits: Pollution degree:	type gG fuse 2 A 500 V 3
		Alternating current: AC15 (50÷60 Hz) U _e (V) 24 I _e (A) 2 Direct current: DC13 U _e (V) 24 I _e (A) 2



Features approved by IMQ

Rated insulation voltage (Ui): 500 Vac
 400 Vac (for contact blocks 2, 11, 12, 20, 21, 22, 28, 29, 30, 33, 34, 37)

Conventional free air thermal current (Ith): 10 A

Protection against short circuits: type aM fuse 10 A 500 V

Rated impulse withstand voltage (U_{imp}): 6 kV
 4 kV (for contact blocks 20, 21, 22, 28, 29, 30, 33, 34)

Protection degree of the housing: IP67

MV terminals (screw terminals)

Pollution degree: 3

Utilization category: AC15

Operating voltage (U_e): 400 Vac (50 Hz)

Operating current (I_e): 3 A

Forms of the contact element: Za, Za+Za, X+X, Zb, Y+Y, Y+Y+X, Y+Y+Y, Y+X+X, Y, X.

Positive opening of contacts on contact blocks 5, 6, 7, 8, 9, 11, 13, 14, 16, 17, 18, 19, 20, 21, 22, 28, 29, 30, 33, 34, 37, 38, 39, 66.

In compliance with standards: EN 60947-1, EN 60947-5-1, fundamental requirements of the Low Voltage Directive 2014/35/EU.

Please contact our technical department for the list of approved products.

Features approved by UL

Electrical Ratings: Q300 pilot duty (69 VA, 125-250 V dc)
 A600 pilot duty (720 VA, 120-600 V ac)

Environmental Ratings: Types 1, 4X, 12, 13

For all contact blocks except 2 and 3 use 60 or 75°C copper (Cu) conductors, rigid or flexible, wire size 12, 14 AWG. Tightening torque for terminal screws of 7.1 lb in (0.8 Nm).

For contact blocks 2 and 3 use 60 or 75°C copper (Cu) conductors, rigid or flexible, wire size 14 AWG. Tightening torque for terminal screws of 12 lb in (1.4 Nm).

Please contact our technical department for the list of approved products.

Wiring diagram for M12 connectors

Contact block 2 2x(1NO-1NC)	Contact block 5 1NO+1NC	Contact block 6 1NO+1NC	Contact block 7 1NO+1NC	Contact block 9 2NC	Contact block 10 2NO	Contact block 11 2NC	Contact block 12 2NO	Contact block 13 2NC
Contacts Pin no.	Contacts Pin no.	Contacts Pin no.	Contacts Pin no.	Contacts Pin no.	Contacts Pin no.	Contacts Pin no.	Contacts Pin no.	Contacts Pin no.
NO 3-4	NC 1-2	NC 1-2	NC 1-2	NC 1-2	NO 1-2	NC 1-2	NO 1-2	NC (1°) 1-2
NC 5-6	NO 3-4	NO 3-4	NO 3-4	NC 3-4	NO 3-4	NC 3-4	NO 3-4	NC (2°) 3-4
NC 7-8	ground 5	ground 5	ground 5	ground 5	ground 5	ground 5	ground 5	ground 5
NO 1-2								

Contact block 14 2NC	Contact block 15 2NO	Contact block 16 2NC	Contact block 18 1NO+1NC	Contact block 20 1NO+2NC	Contact block 21 3NC	Contact block 22 2NO+1NC	Contact block 33 1NO+1NC	Contact block 34 2NC
Contacts Pin no.	Contacts Pin no.	Contacts Pin no.	Contacts Pin no.	Contacts Pin no.	Contacts Pin no.	Contacts Pin no.	Contacts Pin no.	Contacts Pin no.
NC (1°) 1-2	NO (1°) 1-2	NC, lever to the right 1-2	NC 1-2	NC 3-4	NC 3-4	NC 3-4	NC 1-2	NC 1-2
NC (2°) 3-4	NO (2°) 3-4	NC, lever to the left 3-4	NO 3-4	NC 5-6	NC 5-6	NO 5-6	NO 3-4	NC 3-4
ground 5	ground 5	ground 5	ground 5	NO 7-8	NC 7-8	NO 7-8	ground 5	ground 5
				ground 1	ground 1	ground 1		

Contact block E1
PNP

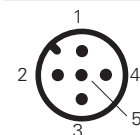

M12 connector, 5-pole

Contacts	Pin no.
+	1
-	3
NC	2
NO	4
ground	5

- Contact type
- R** = snap action
 - L** = slow action
 - LO** = slow action, make before break
 - LS** = slow action, shifted
 - LV** = slow action, shifted and spaced
 - LI** = slow action, independent
 - LA** = slow action, close
 - ⚡** = electronic, PNP

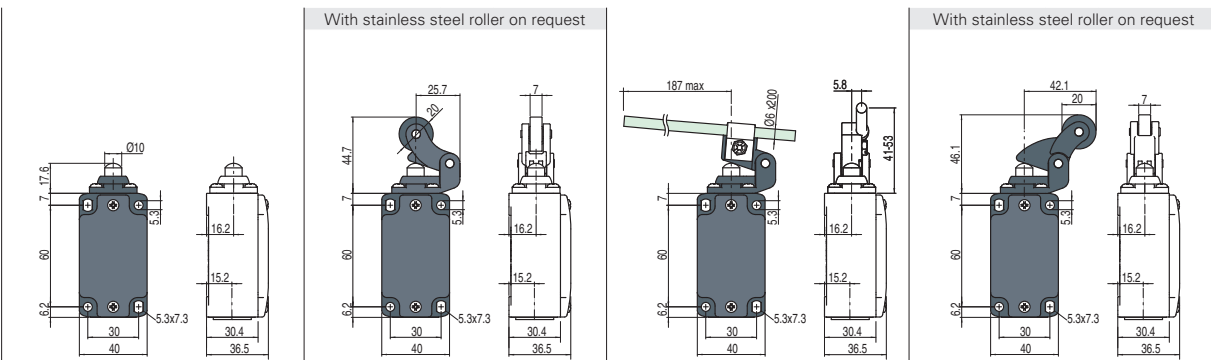

Contact block	FD 201-M2	2x(1NO-1NC)	FD 202-M2	2x(1NO-1NC)	FD 204-M2	2x(1NO-1NC)	FD 205-M2	2x(1NO-1NC)	
2	R	FD 201-M2	2x(1NO-1NC)	FD 202-M2	2x(1NO-1NC)	FD 204-M2	2x(1NO-1NC)	FD 205-M2	2x(1NO-1NC)
5	R	FD 501-M2	1NO+1NC	FD 502-M2	1NO+1NC	FD 504-M2	1NO+1NC	FD 505-M2	1NO+1NC
6	L	FD 601-M2	1NO+1NC	FD 602-M2	1NO+1NC	FD 604-M2	1NO+1NC	FD 605-M2	1NO+1NC
7	LO	FD 701-M2	1NO+1NC	FD 702-M2	1NO+1NC	FD 704-M2	1NO+1NC	FD 705-M2	1NO+1NC
9	L	FD 901-M2	2NC	FD 902-M2	2NC	FD 904-M2	2NC	FD 905-M2	2NC
10	L	FD 1001-M2	2NO	FD 1002-M2	2NO	FD 1004-M2	2NO	FD 1005-M2	2NO
11	R	FD 1101-M2	2NC	FD 1102-M2	2NC	FD 1104-M2	2NC	FD 1105-M2	2NC
12	R	FD 1201-M2	2NO	FD 1202-M2	2NO	FD 1204-M2	2NO	FD 1205-M2	2NO
13	LV	FD 1301-M2	2NC	FD 1302-M2	2NC	FD 1304-M2	2NC	FD 1305-M2	2NC
14	LS	FD 1401-M2	2NC	FD 1402-M2	2NC	FD 1404-M2	2NC	FD 1405-M2	2NC
15	LS	FD 1501-M2	2NO	FD 1502-M2	2NO	FD 1504-M2	2NO	FD 1505-M2	2NO
18	LA	FD 1801-M2	1NO+1NC	FD 1802-M2	1NO+1NC	FD 1804-M2	1NO+1NC	FD 1805-M2	1NO+1NC
20	L	FD 2001-M2	1NO+2NC	FD 2002-M2	1NO+2NC	FD 2004-M2	1NO+2NC	FD 2005-M2	1NO+2NC
21	L	FD 2101-M2	3NC	FD 2102-M2	3NC	FD 2104-M2	3NC	FD 2105-M2	3NC
22	L	FD 2201-M2	2NO+1NC	FD 2202-M2	2NO+1NC	FD 2204-M2	2NO+1NC	FD 2205-M2	2NO+1NC
E1	⚡	FD E101-M2	1NO-1NC	FD E102-M2	1NO-1NC	FD E104-M2	1NO-1NC	FD E105-M2	1NO-1NC
Max. speed	page 227 - type 4		page 227 - type 3		0.5 m/s		page 227 - type 3		
Actuating force	8 N (25 N ⊕)		6 N (25 N ⊕)		0.17 Nm		6 N (25 N ⊕)		
Travel diagrams	page 228 - group 1		page 228 - group 2		page 228 - group 1		page 228 - group 2		

- Contact type
- R** = snap action
 - L** = slow action
 - LO** = slow action, make before break
 - LS** = slow action, shifted
 - LV** = slow action, shifted and spaced
 - LI** = slow action, independent
 - LA** = slow action, close
 - ⚡** = electronic, PNP

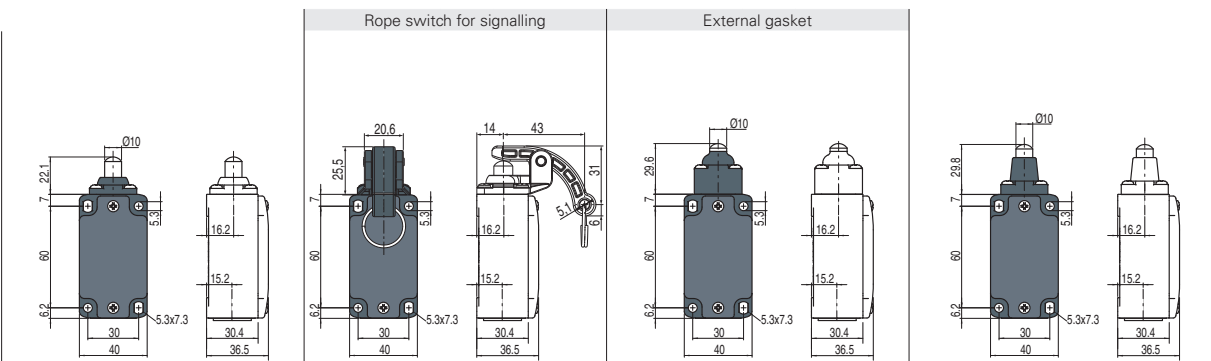

Contact block	FD 208-M2	2x(1NO-1NC)	FD 209-M2	2x(1NO-1NC)	FD 210-M2	2x(1NO-1NC)	FD 211-M2	2x(1NO-1NC)	
2	R	FD 208-M2	2x(1NO-1NC)	FD 209-M2	2x(1NO-1NC)	FD 210-M2	2x(1NO-1NC)	FD 211-M2	2x(1NO-1NC)
5	R	FD 508-M2	1NO+1NC	FD 509-M2	1NO+1NC	FD 510-M2	1NO+1NC	FD 511-M2	1NO+1NC
6	L	FD 608-M2	1NO+1NC	FD 609-M2	1NO+1NC	FD 610-M2	1NO+1NC	FD 611-M2	1NO+1NC
7	LO	FD 708-M2	1NO+1NC	FD 709-M2	1NO+1NC	FD 710-M2	1NO+1NC	FD 711-M2	1NO+1NC
9	L	FD 908-M2	2NC	FD 909-M2	2NC	FD 910-M2	2NC	FD 911-M2	2NC
10	L	FD 1008-M2	2NO	FD 1009-M2	2NO	FD 1010-M2	2NO	FD 1011-M2	2NO
11	R	FD 1108-M2	2NC	FD 1109-M2	2NC	FD 1110-M2	2NC	FD 1111-M2	2NC
12	R	FD 1208-M2	2NO	FD 1209-M2	2NO	FD 1210-M2	2NO	FD 1211-M2	2NO
13	LV	FD 1308-M2	2NC	FD 1309-M2	2NC	FD 1310-M2	2NC	FD 1311-M2	2NC
14	LS	FD 1408-M2	2NC	FD 1409-M2	2NC	FD 1410-M2	2NC	FD 1411-M2	2NC
15	LS	FD 1508-M2	2NO	FD 1509-M2	2NO	FD 1510-M2	2NO	FD 1511-M2	2NO
18	LA	FD 1808-M2	1NO+1NC	FD 1809-M2	1NO+1NC	FD 1810-M2	1NO+1NC	FD 1811-M2	1NO+1NC
20	L	FD 2008-M2	1NO+2NC	FD 2009-M2	1NO+2NC	FD 2010-M2	1NO+2NC	FD 2011-M2	1NO+2NC
21	L	FD 2108-M2	3NC	FD 2109-M2	3NC	FD 2110-M2	3NC	FD 2111-M2	3NC
22	L	FD 2208-M2	2NO+1NC	FD 2209-M2	2NO+1NC	FD 2210-M2	2NO+1NC	FD 2211-M2	2NO+1NC
E1	⚡	FD E108-M2	1NO-1NC	FD E109-M2	1NO-1NC	FD E110-M2	1NO-1NC	FD E111-M2	1NO-1NC
Max. speed	page 227 - type 4		0.5 m/s		page 227 - type 4		page 227 - type 4		
Actuating force	8 N (25 N ⊕)		7 N		11 N (25 N ⊕)		8 N (25 N ⊕)		
Travel diagrams	page 228 - group 1		/		page 228 - group 1		page 228 - group 1		

All values in the drawings are in mm

Accessories See page 207

→ The 2D and 3D files are available at www.pizzato.com



Contact type	External gasket		Ball, Ø 8 mm, stainless steel		Ball, Ø 12.7 mm, stainless steel	
= snap action	= slow action	= slow action, make before break	= slow action, shifted	= slow action, shifted and spaced	= slow action, independent	= slow action, close
= slow action, close	= electronic, PNP					
Max. speed	page 227 - type 2		page 227 - type 2		page 227 - type 4	
Actuating force	11 N (25 N		8 N (25 N		8 N (25 N	
Travel diagrams	page 228 - group 1		page 228 - group 1		page 228 - group 1	

Contact type	External gasket		External gasket		External gasket		Other rollers available. See page 24	
= snap action	= slow action	= slow action, make before break	= slow action, shifted	= slow action, shifted and spaced	= slow action, independent	= slow action, close	= electronic, PNP	
= slow action, close	= electronic, PNP							
Max. speed	1 m/s		1 m/s		1 m/s		page 227 - type 1	
Actuating force	0.09 Nm		0.08 Nm		0.14 Nm		0.1 Nm (0.25 Nm	
Travel diagrams	page 228 - group 3		page 228 - group 3		page 228 - group 3		page 228 - group 4	

All values in the drawings are in mm

Accessories See page 207

➔ The 2D and 3D files are available at www.pizzato.com

FD series position switches

Contact type	Round rod, Ø 3 mm, stainless steel		Square rod, 3x3 mm		Other rollers available. See page 24	Other rollers available. See page 24			
	= snap action	= slow action	= slow action, make before break	= slow action, shifted		= slow action, shifted and spaced	= slow action, independent	= slow action, close	= electronic, PNP
2		FD 232-M2	2x(1NO-1NC)	FD 233-M2	2x(1NO-1NC)	FD 234-M2	2x(1NO-1NC)	FD 235-M2	2x(1NO-1NC)
5		FD 532-M2	1NO+1NC	FD 533-M2	1NO+1NC	FD 534-M2	1NO+1NC	FD 535-M2	(1) 1NO+1NC
6		FD 632-M2	1NO+1NC	FD 633-M2	1NO+1NC	FD 634-M2	1NO+1NC	FD 635-M2	(1) 1NO+1NC
7		FD 732-M2	1NO+1NC	FD 733-M2	1NO+1NC	FD 734-M2	1NO+1NC	FD 735-M2	(1) 1NO+1NC
9		FD 932-M2	2NC	FD 933-M2	2NC	FD 934-M2	2NC	FD 935-M2	(1) 2NC
10		FD 1032-M2	2NO	FD 1033-M2	2NO	FD 1034-M2	2NO	FD 1035-M2	2NO
11		FD 1132-M2	2NC	FD 1133-M2	2NC	FD 1134-M2	2NC	FD 1135-M2	(1) 2NC
12		FD 1232-M2	2NO	FD 1233-M2	2NO	FD 1234-M2	2NO	FD 1235-M2	2NO
13		FD 1332-M2	2NC	FD 1333-M2	2NC	FD 1334-M2	2NC	FD 1335-M2	(1) 2NC
14		FD 1432-M2	2NC	FD 1433-M2	2NC	FD 1434-M2	2NC	FD 1435-M2	(1) 2NC
15		FD 1532-M2	2NO	FD 1533-M2	2NO	FD 1534-M2	2NO	FD 1535-M2	2NO
16		FD 1632-M2	2NC	FD 1633-M2	2NC	FD 1634-M2	2NC	FD 1635-M2	(1) 2NC
18		FD 1832-M2	1NO+1NC	FD 1833-M2	1NO+1NC	FD 1834-M2	1NO+1NC	FD 1835-M2	(1) 1NO+1NC
20		FD 2032-M2	1NO+2NC	FD 2033-M2	1NO+2NC	FD 2034-M2	1NO+2NC	FD 2035-M2	(1) 1NO+2NC
21		FD 2132-M2	3NC	FD 2133-M2	3NC	FD 2134-M2	3NC	FD 2135-M2	(1) 3NC
22		FD 2232-M2	2NO+1NC	FD 2233-M2	2NO+1NC	FD 2234-M2	2NO+1NC	FD 2235-M2	(1) 2NO+1NC
E1		FD E132-M2	1NO-1NC	FD E133-M2	1NO-1NC	FD E134-M2	1NO-1NC	FD E135-M2	1NO-1NC
Max. speed	1.5 m/s		1.5 m/s		1 m/s		page 227 - type 1		
Actuating force	0.1 Nm		0.1 Nm		0.1 Nm		0.1 Nm (0.25 Nm)		
Travel diagrams	page 228 - group 4		page 228 - group 4		page 228 - group 4		page 228 - group 4		

Contact type	Glass fibre rod	Other rollers available. See page 24		Other rollers available. See page 24		Porcelain roller			
	= snap action	= slow action	= slow action, make before break	= slow action, shifted	= slow action, shifted and spaced	= slow action, independent	= slow action, close	= electronic, PNP	
2		FD 236-M2	2x(1NO-1NC)	FD 251-M2	2x(1NO-1NC)	FD 252-M2	2x(1NO-1NC)	FD 253-E11M2	2x(1NO-1NC)
5		FD 536-M2	1NO+1NC	FD 551-M2	1NO+1NC	FD 552-M2	1NO+1NC	FD 553-E11M2V9	1NO+1NC
6		FD 636-M2	1NO+1NC	FD 651-M2	1NO+1NC	FD 652-M2	1NO+1NC	FD 653-E11M2V9	1NO+1NC
7		FD 736-M2	1NO+1NC	FD 751-M2	1NO+1NC	FD 752-M2	1NO+1NC	FD 753-E11M2V9	1NO+1NC
9		FD 936-M2	2NC	FD 951-M2	2NC	FD 952-M2	2NC	FD 953-E11M2V9	2NC
10		FD 1036-M2	2NO	FD 1051-M2	2NO	FD 1052-M2	2NO	FD 1053-E11M2V9	2NO
11		FD 1136-M2	2NC	FD 1151-M2	2NC	FD 1152-M2	2NC	/	
12		FD 1236-M2	2NO	FD 1251-M2	2NO	FD 1252-M2	2NO	FD 1253-E11M2V9	2NO
13		FD 1336-M2	2NC	FD 1351-M2	2NC	FD 1352-M2	2NC	FD 1353-E11M2V9	2NC
14		FD 1436-M2	2NC	FD 1451-M2	2NC	FD 1452-M2	2NC	FD 1453-E11M2V9	2NC
15		FD 1536-M2	2NO	FD 1551-M2	2NO	FD 1552-M2	2NO	FD 1553-E11M2V9	2NO
16		FD 1636-M2	2NC	/		/		/	
18		FD 1836-M2	1NO+1NC	FD 1851-M2	1NO+1NC	FD 1852-M2	1NO+1NC	FD 1853-E11M2V9	1NO+1NC
20		FD 2036-M2	1NO+2NC	FD 2051-M2	1NO+2NC	FD 2052-M2	1NO+2NC	FD 2053-E11M2V9	1NO+2NC
21		FD 2136-M2	3NC	FD 2151-M2	3NC	FD 2152-M2	3NC	FD 2153-E11M2V9	3NC
22		FD 2236-M2	2NO+1NC	FD 2251-M2	2NO+1NC	FD 2252-M2	2NO+1NC	FD 2253-E11M2V9	2NO+1NC
E1		FD E136-M2	1NO-1NC	FD E151-M2	1NO-1NC	FD E152-M2	1NO-1NC	FD E153-E11M2V9	1NO-1NC
Max. speed	1.5 m/s		page 227 - type 1		page 227 - type 1		0.5 m/s		
Actuating force	0.1 Nm		0.06 Nm (0.25 Nm)		0.06 Nm (0.25 Nm)		0.03 Nm (0.25 Nm)		
Travel diagrams	page 228 - group 4		page 228 - group 4		page 228 - group 4		page 228 - group 5		

(1) Positive opening only with actuator set to max. See page 24.

All values in the drawings are in mm

Accessories See page 207

→ The 2D and 3D files are available at www.pizzato.com

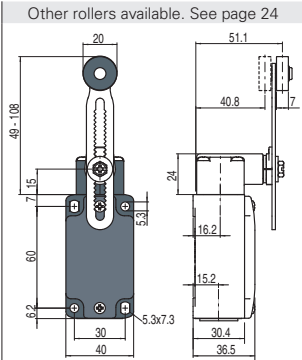
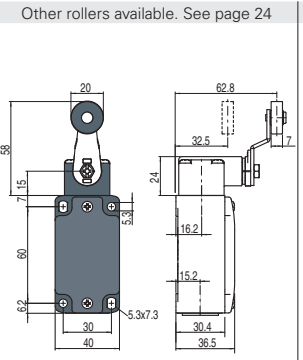
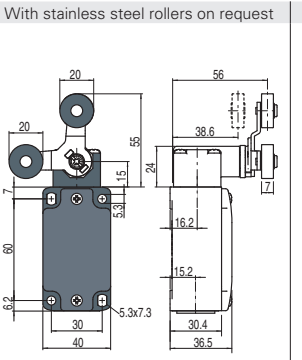
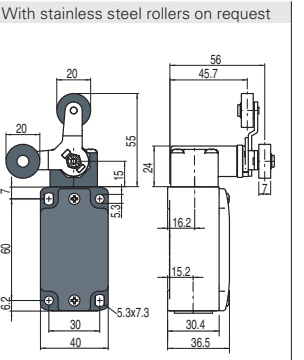
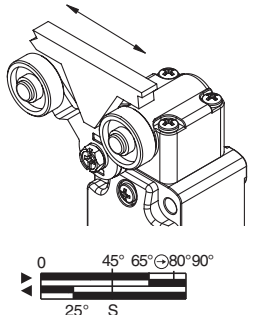
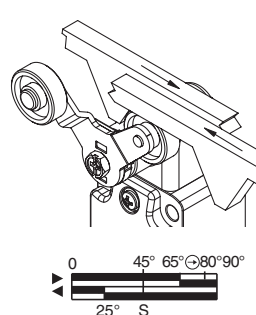

Contact type	Other rollers available. See page 24		Other rollers available. See page 24		With stainless steel rollers on request		With stainless steel rollers on request		
<ul style="list-style-type: none"> R = snap action L = slow action LO = slow action, make before break LS = slow action, shifted LV = slow action, shifted and spaced LI = slow action, independent LA = slow action, close Λ = electronic, PNP 									
Contact block									
2	R	FD 256-M2	2x(1NO-1NC)	FD 257-M2	2x(1NO-1NC)	/	/		
5	R	FD 556-M2	1NO+1NC	FD 557-M2	1NO+1NC	FD 541-M2	1NO+1NC	FD 542-M2	
6	L	FD 656-M2	1NO+1NC	FD 657-M2	1NO+1NC	Bistable switch with lyra lever, single track		Bistable switch with lyra lever, dual track	
7	LO	FD 756-M2	1NO+1NC	FD 757-M2	1NO+1NC	 <p>S = mechanical switching point positive opening on contacts 21-22 only</p>		 <p>S = mechanical switching point positive opening on contacts 21-22 only</p>	
9	L	FD 956-M2	2NC	FD 957-M2	2NC				
10	L	FD 1056-M2	2NO	FD 1057-M2	2NO				
11	R	FD 1156-M2	2NC	FD 1157-M2	2NC				
12	R	FD 1256-M2	2NO	FD 1257-M2	2NO				
13	LV	FD 1356-M2	2NC	FD 1357-M2	2NC				
14	LS	FD 1456-M2	2NC	FD 1457-M2	2NC				
15	LS	FD 1556-M2	2NO	FD 1557-M2	2NO				
16	LI	FD 1656-M2	2NC	FD 1657-M2	2NC				
18	LA	FD 1856-M2	1NO+1NC	FD 1857-M2	1NO+1NC				
20	L	FD 2056-M2	1NO+2NC	FD 2057-M2	1NO+2NC				
21	L	FD 2156-M2	3NC	FD 2157-M2	3NC				
22	L	FD 2256-M2	2NO+1NC	FD 2257-M2	2NO+1NC				
E1	Λ	FD E156-M2	1NO-1NC	FD E157-M2	1NO-1NC				
Max. speed	page 227 - type 1		page 227 - type 1		0.5 m/s with cam at 30°		0.5 m/s with cam at 30°		
Actuating force	0.1 Nm (0.25 Nm ⊕)		0.1 Nm (0.25 Nm ⊕)		0.21 Nm (0.36 Nm ⊕)		0.21 Nm (0.36 Nm ⊕)		
Travel diagrams	page 228 - group 4		page 228 - group 4		/		/		

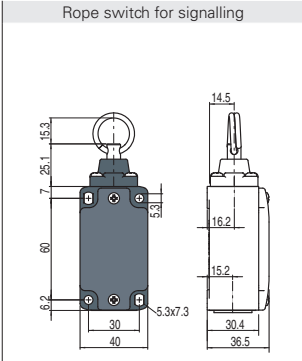
Contact type	Rope switch for signalling		
<ul style="list-style-type: none"> R = snap action L = slow action LO = slow action, make before break LS = slow action, shifted LV = slow action, shifted and spaced LI = slow action, independent LA = slow action, close Λ = electronic, PNP 			
Contact block			
2	R	FD 276-M2	2x(1NO-1NC)
5	R	FD 576-M2	1NO+1NC
6	L	FD 676-M2	1NO+1NC
7	LO	FD 776-M2	1NO+1NC
9	L	FD 976-M2	2NO
10	L	FD 1076-M2	2NC
11	R	FD 1176-M2	2NO
12	R	FD 1276-M2	2NC
13	LV	FD 1376-M2	2NO
14	LS	FD 1476-M2	2NO
15	LS	FD 1576-M2	2NC
16	LI	/	
18	LA	FD 1876-M2	1NO+1NC
20	L	FD 2076-M2	2NO+1NC
21	L	FD 2176-M2	3NO
22	L	FD 2276-M2	1NO+2NC
E1	Λ	/	
Max. speed	0.5 m/s		
Actuating force	initial 20 N - final 40 N		
Travel diagrams	page 228 - group 6		

All values in the drawings are in mm

Accessories See page 207

→ The 2D and 3D files are available at www.pizzato.com

2 FD series position switches

Position switches with swivelling lever without actuator

- Contact type
- R** = snap action
 - L** = slow action
 - LO** = slow action, make before break
 - LS** = slow action, shifted
 - LV** = slow action, shifted and spaced
 - LI** = slow action, independent
 - LA** = slow action, close
 - A** = electronic, PNP

Contact block

	Regular head	Compact head	
2	R FD 238-M2	2x(1NO-1NC)	FD 258-M2
5	R FD 538-M2	1NO+1NC	FD 558-M2
6	L FD 638-M2	1NO+1NC	FD 658-M2
7	LO FD 738-M2	1NO+1NC	FD 758-M2
9	L FD 938-M2	2NC	FD 958-M2
10	L FD 1038-M2	2NO	FD 1058-M2
11	R FD 1138-M2	2NC	FD 1158-M2
12	R FD 1238-M2	2NO	FD 1258-M2
13	LV FD 1338-M2	2NC	FD 1358-M2
14	LS FD 1438-M2	2NC	FD 1458-M2
15	LS FD 1538-M2	2NO	FD 1558-M2
16	LI FD 1638-M2	2NC	/
18	LA FD 1838-M2	1NO+1NC	FD 1858-M2
20	L FD 2038-M2	1NO+2NC	FD 2058-M2
21	L FD 2138-M2	3NC	FD 2158-M2
22	L FD 2238-M2	2NO+1NC	FD 2258-M2
E1	A FD E138-M2	1NO-1NC	FD E158-M2
Actuating force	0.1 Nm (0.25 Nm \rightarrow)	0.06 Nm (0.25 Nm \rightarrow)	0.21 Nm (0.36 Nm \rightarrow)
Travel diagrams	page 228 - group 4	page 228 - group 4	/

IMPORTANT
For safety applications: join only switches and actuators marked with symbol \rightarrow next to the product code.
 For more information about safety applications see details on page 225.

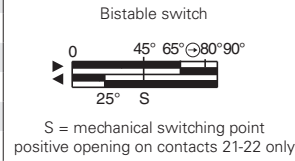

Separate actuators

IMPORTANT: These separate actuators can be used only with items of the FD, FP, FL, FC series.

Technopolymer roller Ø 20 mm	Adjustable round rod Ø 3x125 mm	Adjustable square rod, 3x3x125 mm	Spring rod with plastic tip	Adjustable actuator with technopolymer roller	Adjustable glass fibre rod	
 VF L31 \rightarrow	 VF L32 (3)	 VF L33 (3)	 VF L34	 VF L35 \rightarrow (1) (3)	 VF L36 (3)	
Lyra actuator, single track	Lyra actuator, dual track	Technopolymer roller, Ø 20 mm	Technopolymer roller, Ø 20 mm	Porcelain roller	Adjustable safety actuator with technopolymer roller	Technopolymer roller, Ø 20 mm
 VF L41 \rightarrow	 VF L42 \rightarrow	 VF L51 \rightarrow	 VF L52 \rightarrow	 VF L53 \rightarrow (2)	 VF L56 \rightarrow (3)	 VF L57 \rightarrow

All values in the drawings are in mm

Accessories See page 207

\rightarrow The 2D and 3D files are available at www.pizzato.com



Special separate actuators

IMPORTANT: These separate actuators can be used only with items of the FD, FP, FL, FC series.

Stainless steel rollers, Ø 20 mm

VF L31-R24 (1)	VF L35-R24 (1) (3)	VF L51-R24 (1)	VF L52-R24 (1)	VF L56-R24 (3)	VF L57-R24 (1)

Technopolymer rollers, Ø 35 mm

VF L31-R25 (4)	VF L35-R25 (1) (3)	VF L51-R25 (4)	VF L52-R25 (1)	VF L56-R25 (3)	VF L57-R25 (1)

Rubber rollers, Ø 40 mm

VF L31-R5 (4)	VF L35-R5 (1) (3)	VF L51-R5 (4)	VF L52-R5 (1)	VF L56-R5 (3)	VF L57-R5 (4)

Rubber rollers, Ø 50 mm

VF L31-R26 (4)	VF L35-R26 (1) (3)	VF L51-R26 (4)	VF L52-R26 (4)	VF L56-R26 (3)	VF L57-R26 (4)

Protruding rubber rollers, Ø 50 mm

VF L35-R27 (1) (3)	VF L56-R27 (3)

- (1) Lever VF L35 can only be used in safety applications if adjusted to its max. length, as shown in the figure to the right. If an adjustable lever is required for safety applications, use the VF L56 adjustable safety lever.
- (2) The position switch obtained by assembling switch FD •58-M2 (e.g. FD 558-M2, FD 658-M2, ...) with actuator VF L53 will not present the same travel diagrams and actuating forces as switch FD •53-E11M2V9 (e.g. FD 553-E11M2V9, FD 653-E11M2V9, ...)
- (3) If installed with switch FD •58-M2 (e.g. FD 558-M2, FD 658-M2, ...) the actuator may hit the housing of the switch upon actuation. This possible interference depends on the fixing position of actuator and switch head.
- (4) The actuator cannot be rotated to the inside because it will hit the switch head upon actuation.

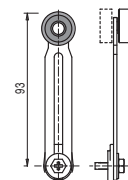

All values in the drawings are in mm

Accessories See page 207

→ The 2D and 3D files are available at www.pizzato.com