

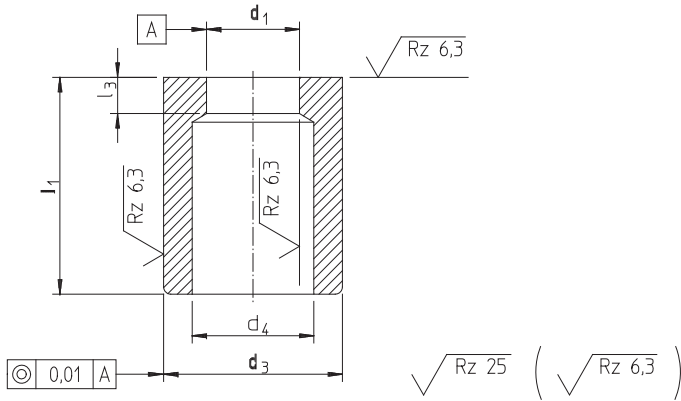

WZ 7011 - WZ 7013

Тип ED



R = закругленный | abgerundet | afgerond | arrondi

Вырубные втулки
 Schneidbuchsen
 Snijbussen
 Matrices de perçage

Material: HWS, 12% Cr
Твердость: 2 ± 2 HRC
Шаг: 0,01 мм

Вырубные втулки с отверстием после электроэрозии поставляются под заказ. Материал HSS или ASP23 и ASP 30 под заказ. Весь ассортимент наших вырубных втулок поставляется в соответствии со стандартами VDI. Длина l_3 вырубного отверстия может отличаться согласно требованиям заказчика.

Material: HWS, 12% Cr
Härte: 62 ± 2 HRC
Stufung: 0,01 мм

Schnittbuchsen mit erodierter Startlochbohrung lieferbar auf Anfrage.

Material HSS oder ASP 23 bzw. ASP 30 auf Wunsch. Alle Schneidbuchsen sind auch nach VDI-Norm lieferbar. Die Länge l_3 des Schnittloches kann anwendungsbezogen verändert werden.

Materiaal: HWS, 12% Cr
Hardheid: 62 ± 2 HRC
Stap: 0,01 мм

Snijbussen voorzien van startgat voor draadvonkerosie zijn leverbaar op aanvraag. Materiaal HSS of ASP 23 en ASP 30 op aanvraag. Alle snijbussen zijn ook volgens de VDI-Norm leverbaar. De lengte l_3 van stanggat kan gewijzigd worden volgens toepassing van de klant.

Matière: HWS, 12% Cr
Dureté: 62 ± 2 HRC
Pas: 0,01 мм

Matrices de perçage avec alésage d'amorçage disponibles sur demande.

Matière HSS ou ASP 23 et ASP 30 sur demande. Toutes les matrices de perçage sont également possible selon les normes VDI. La longueur l_3 des diamètres de coupe peut varier en fonction de l'application.

ПОД ЗАКАЗ | AUF ANFRAGE | OP ANVARAAG | SUR DEMANDE

Артикул l_3	d_3 m5	d_1 +0,01 0	$l_1 \pm 0,05$				d_4	l_3
			19	25	30	32		
WZ 7011	6,0 ₁	1,0 - 3,0					3,5	1,6
WZ 7011	8,0 ₁	1,0 - 4,0					5,0	2,0
WZ 7011	10,0 ₁	2,0 - 5,0					6,5	2,5
WZ 7011	13,0 ₁	3,0 - 7,0					7,5	3,0
WZ 7011	16,0 ₁	4,0 - 8,0					9,0	3,0
WZ 7011	19,0 ₁	5,0 - 10,0					11,0	4,0
WZ 7011	20,0 ₁	6,0 - 11,0					12,0	4,0
WZ 7011	22,0 ₁	9,0 - 13,0					15,0	5,0
WZ 7011	25,0 ₁	12,0 - 16,0					17,0	5,0
WZ 7011	32,0 ₁	13,0 - 20,0					22,0	6,0
WZ 7011	38,0 ₁	16,0 - 26,0					28,0	6,0
WZ 7011	40,0 ₁	21,0 - 29,0					30,0	8,0
WZ 7011	50,0 ₁	29,0 - 37,0					38,0	8,0
WZ 7011	55,0 ₁	35,0 - 41,0					42,0	8,0

Тип EKD

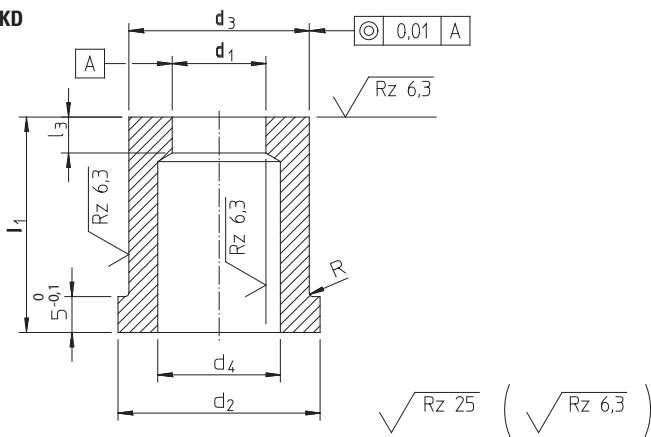

Артикул l_3	d_3 m5	d_1 +0,01 0	$l_1 \pm 0,05$				d_2 +0,3 0	d_4	l_3
			19	25	30	32			
WZ 7013	6,0 ₁	1,0 - 3,0					9,0	3,5	1,6
WZ 7013	8,0 ₁	1,0 - 4,0					11,0	5,0	2,0
WZ 7013	10,0 ₁	2,0 - 5,0					13,0	6,5	2,5
WZ 7013	13,0 ₁	3,0 - 7,0					16,0	7,5	3,0
WZ 7013	16,0 ₁	4,0 - 8,0					19,0	9,0	3,0
WZ 7013	19,0 ₁	5,0 - 10,0					22,0	11,0	4,0
WZ 7013	20,0 ₁	6,0 - 11,0					23,0	12,0	4,0
WZ 7013	22,0 ₁	9,0 - 13,0					25,0	15,0	5,0
WZ 7013	25,0 ₁	12,0 - 16,0					28,0	17,0	5,0
WZ 7013	32,0 ₁	13,0 - 20,0					36,0	22,0	6,0
WZ 7013	38,0 ₁	16,0 - 26,0					42,0	28,0	6,0
WZ 7013	40,0 ₁	21,0 - 29,0					44,0	30,0	8,0
WZ 7013	50,0 ₁	29,0 - 37,0					54,0	38,0	8,0
WZ 7013	55,0 ₁	35,0 - 41,0					58,0	42,0	8,0