

Selection diagram

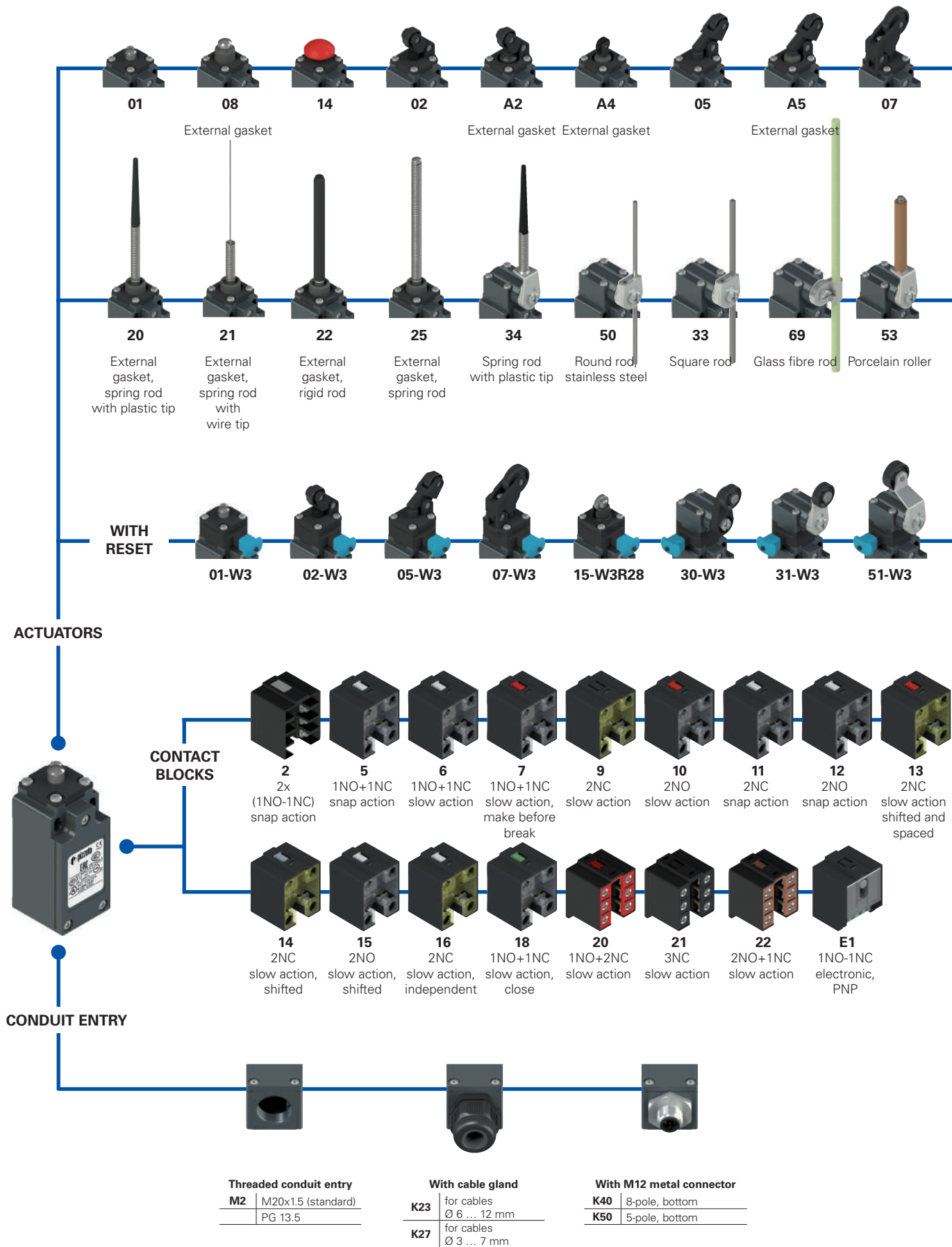
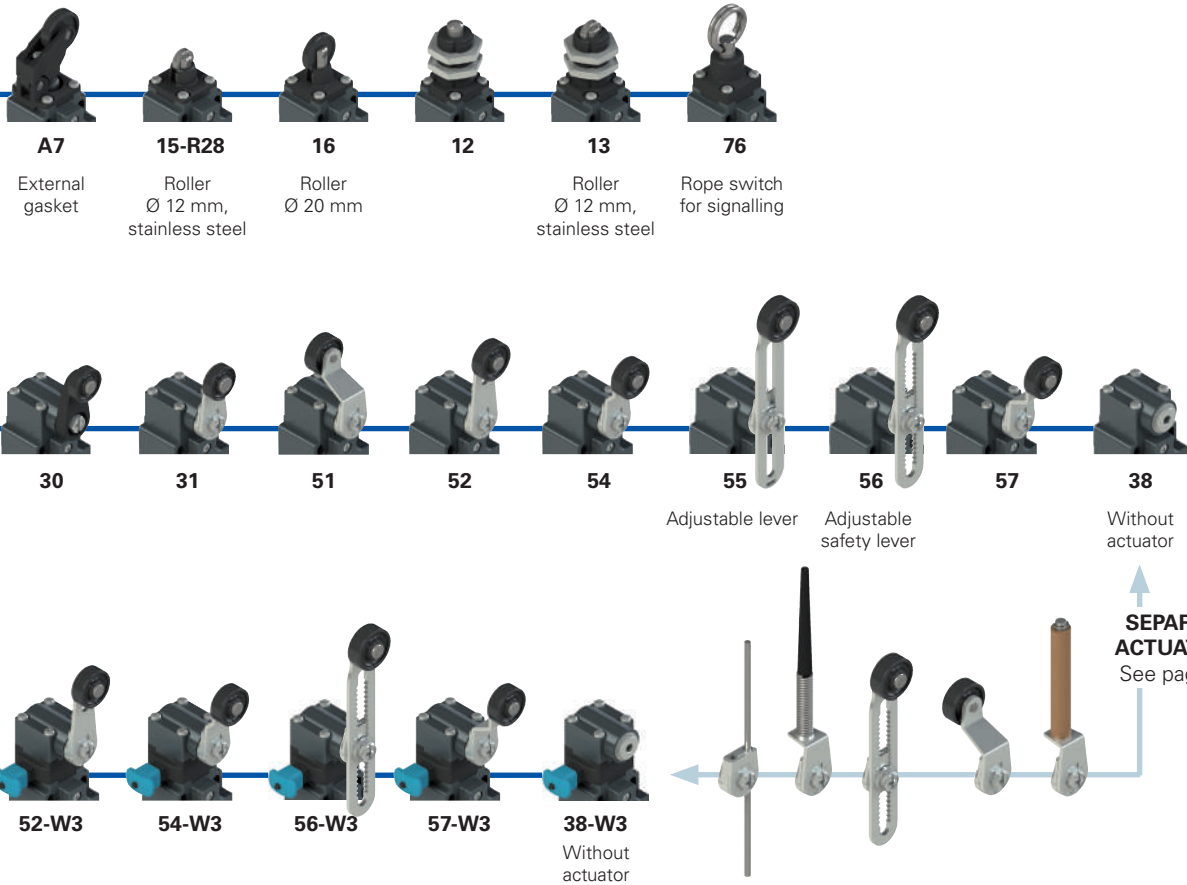

● Product options
→ Sold separately as accessory

Code structure

Attention! The feasibility of a code number does not mean the effective availability of a product. Please contact our sales office.

article
options
options
FM 502-W3GM2K50R23T6

Housing FM metal, one conduit entry		Ambient temperature -25°C ... +80°C (standard) T6 -40°C ... +80°C	
Contact block 5 1NO+1NC, snap action 6 1NO+1NC, slow action 7 1NO+1NC, slow action, make before break		Pre-installed cable glands or connectors no cable gland or connector (standard) K23 cable gland for cables Ø 6 ... 12 mm K50 M12 metal connector, 5-pole	
Actuators 01 short plunger 02 roller lever 05 angled lever with roller		Threaded conduit entry M2 M20x1.5 (standard) PG 13.5	
Reset without reset (standard) W3 simultaneous reset W4 simultaneous reset, increased force		Rollers standard roller R28 stainless steel Ø 12 mm (for actuators A4, 15) R23 stainless steel Ø 14 mm (for actuators A2, 02, A5, 05, 30, 31, 51, 52, 54, 55, 56, 57) R24 stainless steel Ø 20 mm (for actuators 30, 31, 51, 52, 54, 55, 56, 57) R36 stainless steel Ø 16 mm (for actuators 30, 31, 51, 52, 54, 55, 56, 57) R25 technopolymer, Ø 35 mm (for actuators 30, 31, 51, 52, 54, 55, 56, 57) R5 rubber, Ø 40 mm (for actuators 30, 31, 51, 52, 54, 55, 56, 57) R26 rubber, Ø 50 mm (for actuators 51, 52, 54, 55, 56, 57) R27 rubber, protruding, Ø 50 mm (for actuators 55, 56)	
Contact type silver contacts (standard) G silver contacts, 1 µm gold coating G1 silver contacts, 2.5 µm gold coating (except contact blocks 2, 20, 21, 22)			



Main features

- Metal housing, one conduit entry
- Protection degree IP67
- 17 contact blocks available
- 43 actuators available
- Versions with M12 connector
- Versions with gold-plated silver contacts

Technical data

Housing

Metal housing, powder-coated
 One threaded conduit entry: M20x1.5 (standard)
 Protection degree acc. to EN 60529: IP67 with cable gland of equal or higher protection degree

General data

Ambient temperature: -25°C ... +80°C (standard)
 -40°C ... +80°C (T6 option)
 Max. actuation frequency: 3600 operating cycles/hour
 Mechanical endurance: 20 million operating cycles
 Mounting position: any
 Safety parameter B_{10D} : 40,000,000 for NC contacts
 Mechanical interlock, not coded: type 1 acc. to EN ISO 14119
 Tightening torques for installation: see page 229
 Wire cross-sections and wire stripping lengths: see page 247

In compliance with standards:

IEC 60947-5-1, EN 60947-5-1, EN 60947-1, EN 50047, IEC 60204-1, EN 60204-1, EN ISO 14119, EN ISO 12100, IEC 60529, EN 60529, EN IEC 63000, UL 508, CSA 22.2 No.14.

Approvals:

IEC 60947-5-1, UL 508, CSA 22.2 No.14, GB/T14048.5

Compliance with the requirements of:

Low Voltage Directive 2014/35/EU, EMC Directive 2014/30/EU, RoHS Directive 2011/65/EU.

Positive contact opening in conformity with standards:

IEC 60947-5-1, EN 60947-5-1.

Quality marks:



IMQ approval: EG610
 UL approval: E131787
 CCC approval: 2020970305002284
 EAC approval: RU C-IT.YT03.B.00035/19

Installation for safety applications:

Use only switches marked with the symbol \ominus next to the product code. Always connect the safety circuit to the **NC contacts** (normally closed contacts: 11-12, 21-22 or 31-32) as required by **EN ISO 14119, paragraph 5.4** for specific interlock applications and **EN ISO 13849-2 tables D3** (well-tries components) and **D.8** (fault exclusions) for safety applications in general. Actuate the switch **at least up to the positive opening travel** shown in the travel diagrams on page 230. Actuate the switch **at least with the positive opening force**, reported in brackets below each article, next to the actuating force value.

⚠ If not expressly indicated in this chapter, for correct installation and utilization of all articles see the instructions given on pages 225 to 240.

	Electrical data	Utilization category
without connector	Thermal current (I_{th}):	10 A
	Rated insulation voltage (U):	500 Vac 600 Vdc 400 Vac 500 Vdc (contact blocks 2, 11, 12, 20, 21, 22)
	Rated impulse withstand voltage (U_{imp}):	6 kV 4 kV (contact blocks 20, 21, 22)
	Conditional short circuit current: Protection against short circuits: Pollution degree:	1000 A acc. to EN 60947-5-1 type aM fuse 10 A 500 V 3
		Alternating current: AC15 (50±60 Hz) Ue (V) 250 400 500 Ie (A) 6 4 1 Direct current: DC13 Ue (V) 24 125 250 Ie (A) 3 0.55 0.3
with M12 connector, 5-pole	Thermal current (I_{th}):	4 A
	Rated insulation voltage (U):	250 Vac 300 Vdc
	Protection against short circuits: Pollution degree:	type gG fuse 4 A 500 V 3
		Alternating current: AC15 (50±60 Hz) Ue (V) 24 120 250 Ie (A) 4 4 4 Direct current: DC13 Ue (V) 24 125 250 Ie (A) 3 0.55 0.3
with M12 connector, 8-pole	Thermal current (I_{th}):	2 A
	Rated insulation voltage (U):	30 Vac 36 Vdc
	Protection against short circuits: Pollution degree:	type gG fuse 2 A 500 V 3
		Alternating current: AC15 (50±60 Hz) Ue (V) 24 Ie (A) 2 Direct current: DC13 Ue (V) 24 Ie (A) 2

Features approved by IMQ

Rated insulation voltage (U_i): 500 Vac
 400 Vac (for contact blocks 2, 11, 12, 20, 21, 22, 28, 29, 30, 37, 33, 34)

Conventional free air thermal current (I_{th}): 10 A

Protection against short circuits: type aM fuse 10 A 500 V

Rated impulse withstand voltage (U_{imp}): 6 kV
 4 kV (for contact blocks 20, 21, 22, 28, 29, 30, 33, 34)

Protection degree of the housing: IP67

MV terminals (screw terminals): 3

Pollution degree: AC15

Utilization category: 400 Vac (50 Hz)

Operating voltage (U_o): 3 A

Operating current (I_o): 3 A

Forms of the contact element: Za, Za+Za, X+X, Zb, Y+Y, Y+Y+X, Y+Y+Y, Y+X+X, Y, X.

Positive opening of contacts on contact blocks 5, 6, 7, 8, 9, 11, 13, 14, 16, 17, 18, 19, 20, 21, 22, 28, 29, 30, 33, 34, 37, 38, 39, 66.

In compliance with standards: EN 60947-1, EN 60947-5-1, fundamental requirements of the Low Voltage Directive 2014/35/EU.

Please contact our technical department for the list of approved products.

Features approved by UL

Electrical Ratings: Q300 pilot duty (69 VA, 125-250 V dc)
 A600 pilot duty (720 VA, 120-600 V ac)

Environmental Ratings: Types 1, 4X, 12, 13

For all contact blocks except 2 and 3 use 60 or 75°C copper (Cu) conductors, rigid or flexible, wire size 12, 14 AWG. Tightening torque for terminal screws of 7.1 lb in (0.8 Nm).

For contact blocks 2 and 3 use 60 or 75°C copper (Cu) conductors, rigid or flexible, wire size 14 AWG. Tightening torque for terminal screws of 12 lb in (1.4 Nm).

Please contact our technical department for the list of approved products.

Wiring diagram for M12 connectors

Contact block 2 2x(1NO-1NC)	Contact block 5 1NO+1NC	Contact block 6 1NO+1NC	Contact block 7 1NO+1NC	Contact block 9 2NC	Contact block 10 2NO	Contact block 11 2NC	Contact block 12 2NO	Contact block 13 2NC	
M12 connector, 8-pole	M12 connector, 5-pole	M12 connector, 5-pole	M12 connector, 5-pole	M12 connector, 5-pole	M12 connector, 5-pole	M12 connector, 5-pole	M12 connector, 5-pole	M12 connector, 5-pole	
Contacts	Pin no.	Contacts	Pin no.	Contacts	Pin no.	Contacts	Pin no.	Contacts	Pin no.
NO	3-4	NC	1-2	NC	1-2	NC	1-2	NO	1-2
NC	5-6	NO	3-4	NO	3-4	NO	3-4	NC	3-4
NC	7-8	ground	5	ground	5	ground	5	ground	5
NO	1-2							NC (1°)	1-2
								NO (2°)	3-4
								ground	5

Contact block 14 2NC	Contact block 15 2NO	Contact block 16 2NC	Contact block 18 1NO+1NC	Contact block 20 1NO+2NC	Contact block 21 3NC	Contact block 22 2NO+1NC	Contact block 33 1NO+1NC	Contact block 34 2NC	
M12 connector, 5-pole	M12 connector, 5-pole	M12 connector, 5-pole	M12 connector, 5-pole	M12 connector, 8-pole	M12 connector, 8-pole	M12 connector, 8-pole	M12 connector, 5-pole	M12 connector, 5-pole	
Contacts	Pin no.	Contacts	Pin no.	Contacts	Pin no.	Contacts	Pin no.	Contacts	Pin no.
NC (1°)	1-2	NO (1°)	1-2	NC, lever to the right	1-2	NC	3-4	NC	1-2
NC (2°)	3-4	NO (2°)	3-4	NC, lever to the left	3-4	NC	5-6	NO	3-4
ground	5	ground	5	ground	5	NO	7-8	ground	5
				ground	1	NC	7-8	ground	5
				ground	1	NO	5-6	ground	5
				ground	1	NC	3-4	ground	5

Contact block E1
PNP

M12 connector, 5-pole

Contacts	Pin no.
+	1
-	3
NC	2
NO	4
ground	5

FM series position switches

- Contact type
- R** = snap action
 - L** = slow action
 - LO** = slow action, make before break
 - LS** = slow action, shifted
 - LV** = slow action, shifted and spaced
 - LI** = slow action, independent
 - LA** = slow action, close
 - ⚡** = electronic, PNP

Contact block

		With stainless steel roller on request		External gasket		External gasket		
		With stainless steel roller on request		With stainless steel roller on request		External gasket		
2	R FM 201-M2 2x(1NO-1NC)	FM 202-M2 2x(1NO-1NC)	FM 2A2-M2 2x(1NO-1NC)	FM 2A4-M2 2x(1NO-1NC)				
5	R FM 501-M2 ⊕ 1NO+1NC	FM 502-M2 ⊕ 1NO+1NC	FM 5A2-M2 ⊕ 1NO+1NC	FM 5A4-M2 ⊕ 1NO+1NC				
6	L FM 601-M2 ⊕ 1NO+1NC	FM 602-M2 ⊕ 1NO+1NC	FM 6A2-M2 ⊕ 1NO+1NC	FM 6A4-M2 ⊕ 1NO+1NC				
7	LO FM 701-M2 ⊕ 1NO+1NC	FM 702-M2 ⊕ 1NO+1NC	FM 7A2-M2 ⊕ 1NO+1NC	FM 7A4-M2 ⊕ 1NO+1NC				
9	L FM 901-M2 ⊕ 2NC	FM 902-M2 ⊕ 2NC	FM 9A2-M2 ⊕ 2NC	FM 9A4-M2 ⊕ 2NC				
10	L FM 1001-M2 2NO	FM 1002-M2 2NO	FM 10A2-M2 2NO	FM 10A4-M2 2NO				
11	R FM 1101-M2 ⊕ 2NC	FM 1102-M2 ⊕ 2NC	FM 11A2-M2 ⊕ 2NC	FM 11A4-M2 ⊕ 2NC				
12	R FM 1201-M2 2NO	FM 1202-M2 2NO	FM 12A2-M2 2NO	FM 12A4-M2 2NO				
13	LV FM 1301-M2 ⊕ 2NC	FM 1302-M2 ⊕ 2NC	FM 13A2-M2 ⊕ 2NC	FM 13A4-M2 ⊕ 2NC				
14	LS FM 1401-M2 ⊕ 2NC	FM 1402-M2 ⊕ 2NC	FM 14A2-M2 ⊕ 2NC	FM 14A4-M2 ⊕ 2NC				
15	LS FM 1501-M2 2NO	FM 1502-M2 2NO	FM 15A2-M2 2NO	FM 15A4-M2 2NO				
18	LA FM 1801-M2 ⊕ 1NO+1NC	FM 1802-M2 ⊕ 1NO+1NC	FM 18A2-M2 ⊕ 1NO+1NC	FM 18A4-M2 ⊕ 1NO+1NC				
20	L FM 2001-M2 ⊕ 1NO+2NC	FM 2002-M2 ⊕ 1NO+2NC	FM 20A2-M2 ⊕ 1NO+2NC	FM 20A4-M2 ⊕ 1NO+2NC				
21	L FM 2101-M2 ⊕ 3NC	FM 2102-M2 ⊕ 3NC	FM 21A2-M2 ⊕ 3NC	FM 21A4-M2 ⊕ 3NC				
22	L FM 2201-M2 ⊕ 2NO+1NC	FM 2202-M2 ⊕ 2NO+1NC	FM 22A2-M2 ⊕ 2NO+1NC	FM 22A4-M2 ⊕ 2NO+1NC				
E1	⚡ FM E101-M2 1NO-1NC	FM E102-M2 1NO-1NC	FM E1A2-M2 1NO-1NC	FM E1A4-M2 1NO-1NC				
Max. speed	page 229 - type 4		page 229 - type 3		page 229 - type 3		page 229 - type 5	
Actuating force	8 N (25 N ⊕)		6 N (25 N ⊕)		4.3 N (25 N ⊕)		4.3 N (25 N ⊕)	
Travel diagrams	page 230 - group 1		page 230 - group 2		page 230 - group 2		page 230 - group 1	

- Contact type
- R** = snap action
 - L** = slow action
 - LO** = slow action, make before break
 - LS** = slow action, shifted
 - LV** = slow action, shifted and spaced
 - LI** = slow action, independent
 - LA** = slow action, close
 - ⚡** = electronic, PNP

Contact block

		With stainless steel roller on request		External gasket		External gasket		
		With stainless steel roller on request		With stainless steel roller on request		External gasket		
2	R FM 205-M2 2x(1NO-1NC)	FM 2A5-M2 2x(1NO-1NC)	FM 207-M2 2x(1NO-1NC)	FM 2A7-M2 2x(1NO-1NC)				
5	R FM 505-M2 ⊕ 1NO+1NC	FM 5A5-M2 ⊕ 1NO+1NC	FM 507-M2 ⊕ 1NO+1NC	FM 5A7-M2 ⊕ 1NO+1NC				
6	L FM 605-M2 ⊕ 1NO+1NC	FM 6A5-M2 ⊕ 1NO+1NC	FM 607-M2 ⊕ 1NO+1NC	FM 6A7-M2 ⊕ 1NO+1NC				
7	LO FM 705-M2 ⊕ 1NO+1NC	FM 7A5-M2 ⊕ 1NO+1NC	FM 707-M2 ⊕ 1NO+1NC	FM 7A7-M2 ⊕ 1NO+1NC				
9	L FM 905-M2 ⊕ 2NC	FM 9A5-M2 ⊕ 2NC	FM 907-M2 ⊕ 2NC	FM 9A7-M2 ⊕ 2NC				
10	L FM 1005-M2 2NO	FM 10A5-M2 2NO	FM 1007-M2 2NO	FM 10A7-M2 2NO				
11	R FM 1105-M2 ⊕ 2NC	FM 11A5-M2 ⊕ 2NC	FM 1107-M2 ⊕ 2NC	FM 11A7-M2 ⊕ 2NC				
12	R FM 1205-M2 2NO	FM 12A5-M2 2NO	FM 1207-M2 2NO	FM 12A7-M2 2NO				
13	LV FM 1305-M2 ⊕ 2NC	FM 13A5-M2 ⊕ 2NC	FM 1307-M2 ⊕ 2NC	FM 13A7-M2 ⊕ 2NC				
14	LS FM 1405-M2 ⊕ 2NC	FM 14A5-M2 ⊕ 2NC	FM 1407-M2 ⊕ 2NC	FM 14A7-M2 ⊕ 2NC				
15	LS FM 1505-M2 2NO	FM 15A5-M2 2NO	FM 1507-M2 2NO	FM 15A7-M2 2NO				
18	LA FM 1805-M2 ⊕ 1NO+1NC	FM 18A5-M2 ⊕ 1NO+1NC	FM 1807-M2 ⊕ 1NO+1NC	FM 18A7-M2 ⊕ 1NO+1NC				
20	L FM 2005-M2 ⊕ 1NO+2NC	FM 20A5-M2 ⊕ 1NO+2NC	FM 2007-M2 ⊕ 1NO+2NC	FM 20A7-M2 ⊕ 1NO+2NC				
21	L FM 2105-M2 ⊕ 3NC	FM 21A5-M2 ⊕ 3NC	FM 2107-M2 ⊕ 3NC	FM 21A7-M2 ⊕ 3NC				
22	L FM 2205-M2 ⊕ 2NO+1NC	FM 22A5-M2 ⊕ 2NO+1NC	FM 2207-M2 ⊕ 2NO+1NC	FM 22A7-M2 ⊕ 2NO+1NC				
E1	⚡ FM E105-M2 1NO-1NC	FM E1A5-M2 1NO-1NC	FM E107-M2 1NO-1NC	FM E1A7-M2 1NO-1NC				
Max. speed	page 229 - type 3		page 229 - type 3		page 229 - type 3		page 229 - type 3	
Actuating force	6 N (25 N ⊕)		4.3 N (25 N ⊕)		4 N (25 N ⊕)		3 N (25 N ⊕)	
Travel diagrams	page 230 - group 2		page 230 - group 2		page 230 - group 3		page 230 - group 3	

All values in the drawings are in mm

Accessories See page 207

→ The 2D and 3D files are available at www.pizzato.com



Contact type	External gasket			
R = snap action				
L = slow action				
LO = slow action, make before break				
LS = slow action, shifted				
LV = slow action, shifted and spaced				
LI = slow action, independent				
LA = slow action, close				
= electronic, PNP				
Contact block	External gasket			
2 R	FM 208-M2	2x(1NO-1NC)	FM 212-M2	2x(1NO-1NC)
5 R	FM 508-M2	1NO+1NC	FM 512-M2	1NO+1NC
6 L	FM 608-M2	1NO+1NC	FM 612-M2	1NO+1NC
7 LO	FM 708-M2	1NO+1NC	FM 712-M2	1NO+1NC
9 L	FM 908-M2	2NC	FM 912-M2	2NC
10 L	FM 1008-M2	2NO	FM 1012-M2	2NO
11 R	FM 1108-M2	2NC	FM 1112-M2	2NC
12 R	FM 1208-M2	2NO	FM 1212-M2	2NO
13 LV	FM 1308-M2	2NC	FM 1312-M2	2NC
14 LS	FM 1408-M2	2NC	FM 1412-M2	2NC
15 LS	FM 1508-M2	2NO	FM 1512-M2	2NO
18 LA	FM 1808-M2	1NO+1NC	FM 1812-M2	1NO+1NC
20 L	FM 2008-M2	1NO+2NC	FM 2012-M2	1NO+2NC
21 L	FM 2108-M2	3NC	FM 2112-M2	3NC
22 L	FM 2208-M2	2NO+1NC	FM 2212-M2	2NO+1NC
E1	FM E108-M2	1NO-1NC	FM E112-M2	1NO-1NC
Max. speed	page 229 - type 4		page 229 - type 4	
Actuating force	8 N (25 N)		8 N (25 N)	
Travel diagrams	page 230 - group 1		page 230 - group 1	

Contact type	Spring rod		Spring rod	
R = snap action				
L = slow action				
LO = slow action, make before break				
LS = slow action, shifted				
LV = slow action, shifted and spaced				
LI = slow action, independent				
LA = slow action, close				
= electronic, PNP				
Contact block	Spring rod		Spring rod	
2 R	FM 215-M2R28	2x(1NO-1NC)	FM 216-M2	2x(1NO-1NC)
5 R	FM 515-M2R28	1NO+1NC	FM 516-M2	1NO+1NC
6 L	FM 615-M2R28	1NO+1NC	FM 616-M2	1NO+1NC
7 LO	FM 715-M2R28	1NO+1NC	FM 716-M2	1NO+1NC
9 L	FM 915-M2R28	2NC	FM 916-M2	2NC
10 L	FM 1015-M2R28	2NO	FM 1016-M2	2NO
11 R	FM 1115-M2R28	2NC	FM 1116-M2	2NC
12 R	FM 1215-M2R28	2NO	FM 1216-M2	2NO
13 LV	FM 1315-M2R28	2NC	FM 1316-M2	2NC
14 LS	FM 1415-M2R28	2NC	FM 1416-M2	2NC
15 LS	FM 1515-M2R28	2NO	FM 1516-M2	2NO
18 LA	FM 1815-M2R28	1NO+1NC	FM 1816-M2	1NO+1NC
20 L	FM 2015-M2R28	1NO+2NC	FM 2016-M2	1NO+2NC
21 L	FM 2115-M2R28	3NC	FM 2116-M2	3NC
22 L	FM 2215-M2R28	2NO+1NC	FM 2216-M2	2NO+1NC
E1	FM E115-M2R28	1NO-1NC	FM E116-M2	1NO-1NC
Max. speed	page 229 - type 2		1 m/s	1 m/s
Actuating force	8 N (25 N)		0.07 Nm	0.07 Nm
Travel diagrams	page 230 - group 1		page 230 - group 4	page 230 - group 4

All values in the drawings are in mm

Accessories See page 207

The 2D and 3D files are available at www.pizzato.com

FM series position switches

- Contact type
- R** = snap action
 - L** = slow action
 - LO** = slow action, make before break
 - LS** = slow action, shifted
 - LV** = slow action, shifted and spaced
 - LI** = slow action, independent
 - LA** = slow action, close
 - ⚡** = electronic, PNP

Contact block

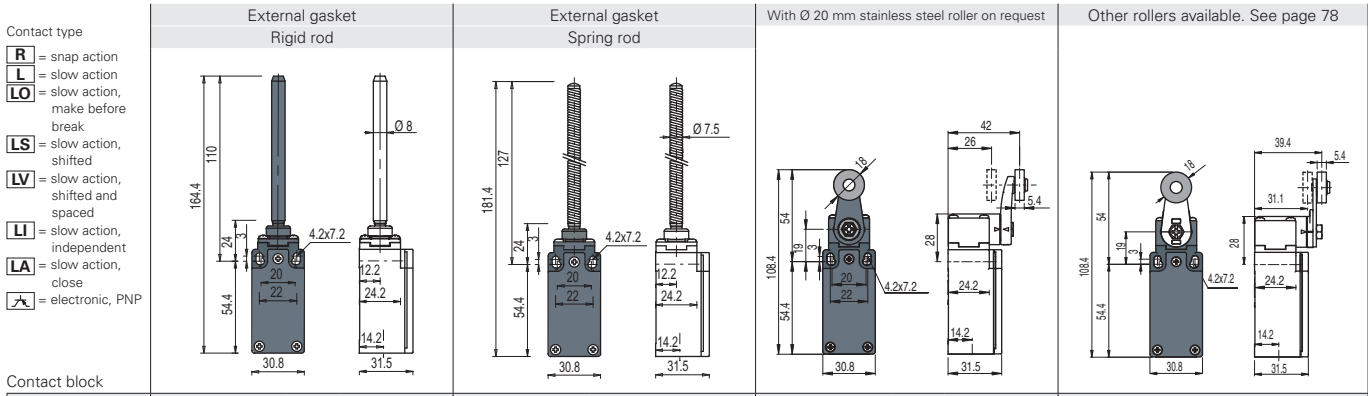

2	R	FM 222-M2	2x(1NO-1NC)	FM 225-M2	2x(1NO-1NC)	FM 230-M2	2x(1NO-1NC)	FM 231-M2	2x(1NO-1NC)
5	R	/	/	FM 525-M2	1NO+1NC	FM 530-M2	⊕ 1NO+1NC	FM 531-M2	⊕ 1NO+1NC
6	L	/	/	/	/	FM 630-M2	⊕ 1NO+1NC	FM 631-M2	⊕ 1NO+1NC
7	LO	/	/	/	/	FM 730-M2	⊕ 1NO+1NC	FM 731-M2	⊕ 1NO+1NC
9	L	/	/	/	/	FM 930-M2	⊕ 2NC	FM 931-M2	⊕ 2NC
10	L	FM 1022-M2	2NO	FM 1025-M2	2NO	FM 1030-M2	2NO	FM 1031-M2	2NO
11	R	/	/	/	/	FM 1130-M2	⊕ 2NC	FM 1131-M2	⊕ 2NC
12	R	FM 1222-M2	2NO	FM 1225-M2	2NO	FM 1230-M2	2NO	FM 1231-M2	2NO
13	LV	/	/	/	/	FM 1330-M2	⊕ 2NC	FM 1331-M2	⊕ 2NC
14	LS	/	/	/	/	FM 1430-M2	⊕ 2NC	FM 1431-M2	⊕ 2NC
15	LS	/	/	/	/	FM 1530-M2	2NO	FM 1531-M2	2NO
16	LI	/	/	/	/	FM 1630-M2	⊕ 2NC	FM 1631-M2	⊕ 2NC
18	LA	FM 1822-M2	⊕ 1NO+1NC	FM 1825-M2	1NO+1NC	FM 1830-M2	⊕ 1NO+1NC	FM 1831-M2	⊕ 1NO+1NC
20	L	FM 2022-M2	⊕ 1NO+2NC	FM 2025-M2	1NO+2NC	FM 2030-M2	⊕ 1NO+2NC	FM 2031-M2	⊕ 1NO+2NC
21	L	FM 2122-M2	⊕ 3NC	FM 2125-M2	3NC	FM 2130-M2	⊕ 3NC	FM 2131-M2	⊕ 3NC
22	L	FM 2222-M2	⊕ 2NO+1NC	FM 2225-M2	2NO+1NC	FM 2230-M2	⊕ 2NO+1NC	FM 2231-M2	⊕ 2NO+1NC
E1	⚡	FM E122-M2	1NO-1NC	FM E125-M2	1NO-1NC	FM E130-M2	1NO-1NC	FM E131-M2	1NO-1NC
Max. speed		1 m/s		1 m/s		page 229 - type 1		page 229 - type 1	
Actuating force		0.12 Nm (0.25 Nm ⊕)		0.12 Nm		0.06 Nm (0.25 Nm ⊕)		0.06 Nm (0.25 Nm ⊕)	
Travel diagrams		page 230 - group 4		page 230 - group 4		page 230 - group 5		page 230 - group 5	

- Contact type
- R** = snap action
 - L** = slow action
 - LO** = slow action, make before break
 - LS** = slow action, shifted
 - LV** = slow action, shifted and spaced
 - LI** = slow action, independent
 - LA** = slow action, close
 - ⚡** = electronic, PNP

Contact block

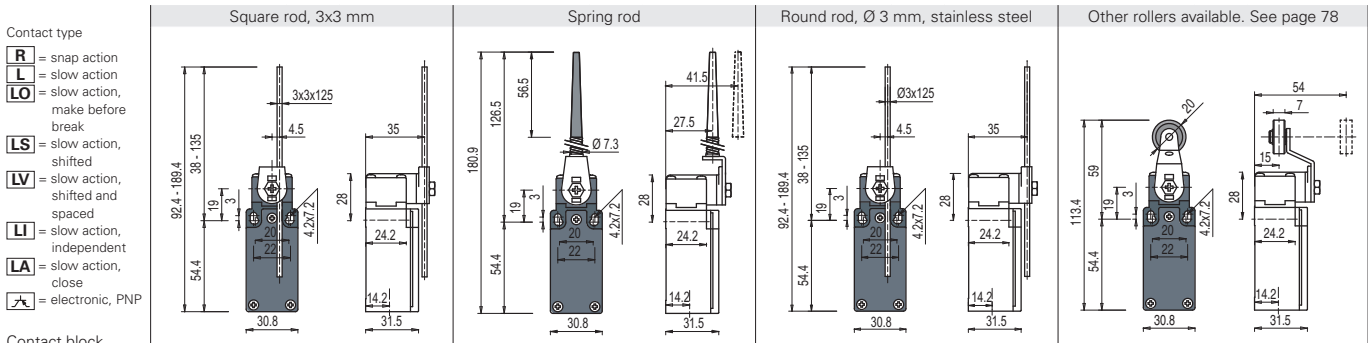

2	R	FM 233-M2	2x(1NO-1NC)	FM 234-M2	2x(1NO-1NC)	FM 250-M2	2x(1NO-1NC)	FM 251-M2	2x(1NO-1NC)
5	R	FM 533-M2	1NO+1NC	FM 534-M2	1NO+1NC	FM 550-M2	1NO+1NC	FM 551-M2	⊕ 1NO+1NC
6	L	FM 633-M2	1NO+1NC	FM 634-M2	1NO+1NC	FM 650-M2	1NO+1NC	FM 651-M2	⊕ 1NO+1NC
7	LO	FM 733-M2	1NO+1NC	FM 734-M2	1NO+1NC	FM 750-M2	1NO+1NC	FM 751-M2	⊕ 1NO+1NC
9	L	FM 933-M2	2NC	FM 934-M2	2NC	FM 950-M2	2NC	FM 951-M2	⊕ 2NC
10	L	FM 1033-M2	2NO	FM 1034-M2	2NO	FM 1050-M2	2NO	FM 1051-M2	2NO
11	R	FM 1133-M2	2NC	FM 1134-M2	2NC	FM 1150-M2	2NC	FM 1151-M2	⊕ 2NC
12	R	FM 1233-M2	2NO	FM 1234-M2	2NO	FM 1250-M2	2NO	FM 1251-M2	2NO
13	LV	FM 1333-M2	2NC	FM 1343-M2	2NC	FM 1350-M2	2NC	FM 1351-M2	⊕ 2NC
14	LS	FM 1433-M2	2NC	FM 1434-M2	2NC	FM 1450-M2	2NC	FM 1451-M2	⊕ 2NC
15	LS	FM 1533-M2	2NO	FM 1534-M2	2NO	FM 1550-M2	2NO	FM 1551-M2	2NO
16	LI	FM 1633-M2	2NC	FM 1634-M2	2NC	FM 1650-M2	2NC	FM 1651-M2	⊕ 2NC
18	LA	FM 1833-M2	1NO+1NC	FM 1834-M2	1NO+1NC	FM 1850-M2	1NO+1NC	FM 1851-M2	⊕ 1NO+1NC
20	L	FM 2033-M2	1NO+2NC	FM 2034-M2	1NO+2NC	FM 2050-M2	1NO+2NC	FM 2051-M2	⊕ 1NO+2NC
21	L	FM 2133-M2	3NC	FM 2134-M2	3NC	FM 2150-M2	3NC	FM 2151-M2	⊕ 3NC
22	L	FM 2233-M2	2NO+1NC	FM 2234-M2	2NO+1NC	FM 2250-M2	2NO+1NC	FM 2251-M2	⊕ 2NO+1NC
E1	⚡	FM E133-M2	1NO-1NC	FM E134-M2	1NO-1NC	FM E150-M2	1NO-1NC	FM E151-M2	1NO-1NC
Max. speed		1.5 m/s		1.5 m/s		1.5 m/s		page 229 - type 1	
Actuating force		0.06 Nm		0.06 Nm		0.06 Nm		0.06 Nm (0.25 Nm ⊕)	
Travel diagrams		page 230 - group 5		page 230 - group 5		page 230 - group 5		page 230 - group 5	

All values in the drawings are in mm

Accessories See page 207

→ The 2D and 3D files are available at www.pizzato.com

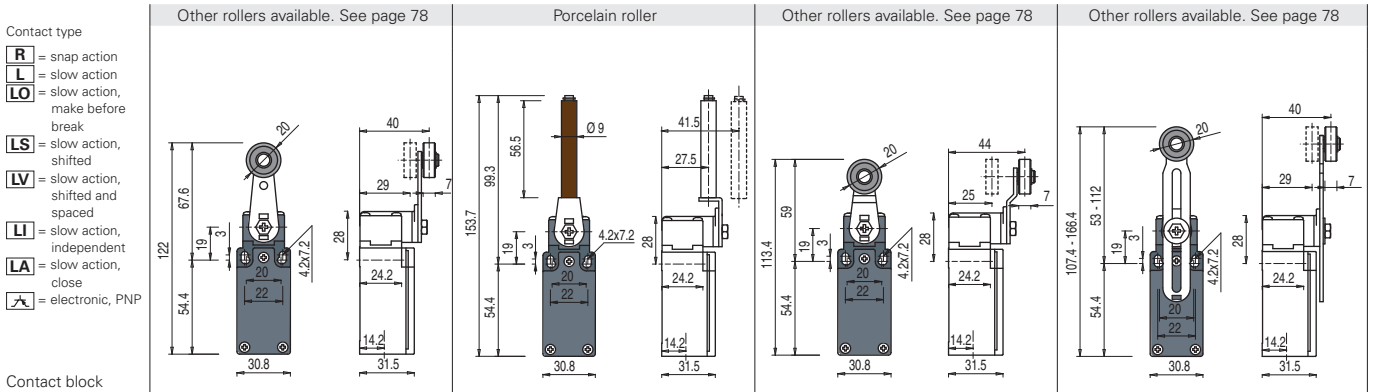

Contact block	Other rollers available. See page 78	Porcelain roller	Other rollers available. See page 78	Other rollers available. See page 78
2	R FM 252-M2 2x(1NO-1NC)	FM 253-E0M2 2x(1NO-1NC)	FM 254-M2 2x(1NO-1NC)	FM 255-M2 2x(1NO-1NC)
5	R FM 552-M2 ⊕ 1NO+1NC	FM 553-E0M2V9 ⊕ 1NO+1NC	FM 554-M2 ⊕ 1NO+1NC	FM 555-M2 ⊕ ⁽¹⁾ 1NO+1NC
6	L FM 652-M2 ⊕ 1NO+1NC	FM 653-E0M2V9 ⊕ 1NO+1NC	FM 654-M2 ⊕ 1NO+1NC	FM 655-M2 ⊕ ⁽¹⁾ 1NO+1NC
7	LO FM 752-M2 ⊕ 1NO+1NC	FM 753-E0M2V9 ⊕ 1NO+1NC	FM 754-M2 ⊕ 1NO+1NC	FM 755-M2 ⊕ ⁽¹⁾ 1NO+1NC
9	L FM 952-M2 ⊕ 2NC	FM 953-E0M2V9 ⊕ 2NC	FM 954-M2 ⊕ 2NC	FM 955-M2 ⊕ ⁽¹⁾ 2NC
10	L FM 1052-M2 2NO	FM 1053-E0M2V9 2NO	FM 1054-M2 2NO	FM 1055-M2 2NO
11	R FM 1152-M2 ⊕ 2NC	/	FM 1154-M2 ⊕ 2NC	FM 1155-M2 ⊕ ⁽¹⁾ 2NC
12	R FM 1252-M2 2NO	FM 1253-E0M2V9 2NO	FM 1254-M2 2NO	FM 1255-M2 2NO
13	LV FM 1352-M2 ⊕ 2NC	FM 1353-E0M2V9 ⊕ 2NC	FM 1354-M2 ⊕ 2NC	FM 1355-M2 ⊕ ⁽¹⁾ 2NC
14	LS FM 1452-M2 ⊕ 2NC	FM 1453-E0M2V9 ⊕ 2NC	FM 1454-M2 ⊕ 2NC	FM 1455-M2 ⊕ ⁽¹⁾ 2NC
15	LS FM 1552-M2 2NO	FM 1553-E0M2V9 2NO	FM 1554-M2 2NO	FM 1555-M2 2NO
16	LI FM 1652-M2 ⊕ 2NC	/	FM 1654-M2 ⊕ 2NC	FM 1655-M2 ⊕ ⁽¹⁾ 2NC
18	LA FM 1852-M2 ⊕ 1NO+1NC	FM 1853-E0M2V9 ⊕ 1NO+1NC	FM 1854-M2 ⊕ 1NO+1NC	FM 1855-M2 ⊕ ⁽¹⁾ 1NO+1NC
20	L FM 2052-M2 ⊕ 1NO+2NC	FM 2053-E0M2V9 ⊕ 1NO+2NC	FM 2054-M2 ⊕ 1NO+2NC	FM 2055-M2 ⊕ ⁽¹⁾ 1NO+2NC
21	L FM 2152-M2 ⊕ 3NC	FM 2153-E0M2V9 ⊕ 3NC	FM 2154-M2 ⊕ 3NC	FM 2155-M2 ⊕ ⁽¹⁾ 3NC
22	L FM 2252-M2 ⊕ 2NO+1NC	FM 2253-E0M2V9 ⊕ 2NO+1NC	FM 2254-M2 ⊕ 2NO+1NC	FM 2255-M2 ⊕ ⁽¹⁾ 2NO+1NC
E1	A FM E152-M2 1NO-1NC	FM E153-E0M2V9 1NO-1NC	FM E154-M2 1NO-1NC	FM E155-M2 1NO-1NC
Max. speed	page 229 - type 1	0.5 m/s	page 229 - type 1	page 229 - type 1
Actuating force	0.06 Nm (0.25 Nm ⊕)	0.03 Nm (0.25 Nm ⊕)	0.06 Nm (0.25 Nm ⊕)	0.06 Nm (0.25 Nm ⊕)
Travel diagrams	page 230 - group 5	page 230 - group 6	page 230 - group 5	page 230 - group 5

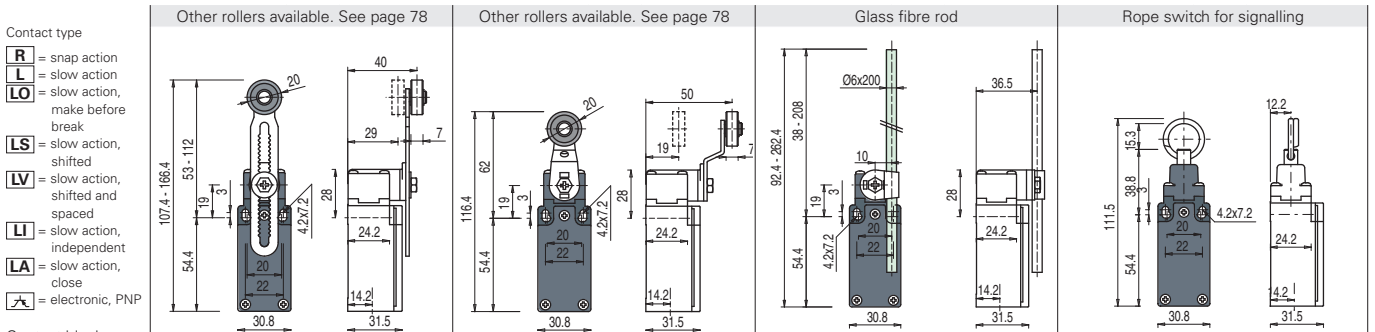

Contact block	Other rollers available. See page 78	Other rollers available. See page 78	Glass fibre rod	Rope switch for signalling
2	R FM 256-M2 2x(1NO-1NC)	FM 257-M2 2x(1NO-1NC)	FM 269-M2 2x(1NO-1NC)	FM 276-M2 2x(1NO-1NC)
5	R FM 556-M2 ⊕ 1NO+1NC	FM 557-M2 ⊕ 1NO+1NC	FM 569-M2 1NO+1NC	FM 576-M2 1NO+1NC
6	L FM 656-M2 ⊕ 1NO+1NC	FM 657-M2 ⊕ 1NO+1NC	FM 669-M2 1NO+1NC	FM 676-M2 1NO+1NC
7	LO FM 756-M2 ⊕ 1NO+1NC	FM 757-M2 ⊕ 1NO+1NC	FM 769-M2 1NO+1NC	FM 776-M2 1NO+1NC
9	L FM 956-M2 ⊕ 2NC	FM 957-M2 ⊕ 2NC	FM 969-M2 2NC	FM 976-M2 2NO
10	L FM 1056-M2 2NO	FM 1057-M2 2NO	FM 1069-M2 2NO	FM 1076-M2 2NC
11	R FM 1156-M2 ⊕ 2NC	FM 1157-M2 ⊕ 2NC	FM 1169-M2 2NC	FM 1176-M2 2NO
12	R FM 1256-M2 2NO	FM 1257-M2 2NO	FM 1269-M2 2NO	FM 1276-M2 2NC
13	LV FM 1356-M2 ⊕ 2NC	FM 1357-M2 ⊕ 2NC	FM 1369-M2 2NC	FM 1376-M2 2NO
14	LS FM 1456-M2 ⊕ 2NC	FM 1457-M2 ⊕ 2NC	FM 1469-M2 2NC	FM 1476-M2 2NO
15	LS FM 1556-M2 2NO	FM 1557-M2 2NO	FM 1569-M2 2NO	FM 1576-M2 2NC
16	LI FM 1656-M2 ⊕ 2NC	FM 1657-M2 ⊕ 2NC	FM 1669-M2 2NC	/
18	LA FM 1856-M2 ⊕ 1NO+1NC	FM 1857-M2 ⊕ 1NO+1NC	FM 1869-M2 1NO+1NC	FM 1876-M2 1NO+1NC
20	L FM 2056-M2 ⊕ 1NO+2NC	FM 2057-M2 ⊕ 1NO+2NC	FM 2069-M2 1NO+2NC	FM 2076-M2 2NO+1NC
21	L FM 2156-M2 ⊕ 3NC	FM 2157-M2 ⊕ 3NC	FM 2169-M2 3NC	FM 2176-M2 3NO
22	L FM 2256-M2 ⊕ 2NO+1NC	FM 2257-M2 ⊕ 2NO+1NC	FM 2269-M2 2NO+1NC	FM 2276-M2 1NO+2NC
E1	A FM E156-M2 1NO-1NC	FM E157-M2 1NO-1NC	FM E169-M2 1NO-1NC	/
Max. speed	page 229 - type 1	page 229 - type 1	1.5 m/s	0.5 m/s
Actuating force	0.06 Nm (0.25 Nm ⊕)	0.06 N (0.25 N ⊕)	0.06 Nm	initial 20 N - final 40 N
Travel diagrams	page 230 - group 5	page 230 - group 5	page 230 - group 5	page 230 - group 7

⁽¹⁾ Positive opening only with actuator set to max. See page 78.
All values in the drawings are in mm

FM series position switches with reset



The majority of switches can be equipped with a reset device (option W3) which enables the simultaneous actuation of actuator and contact block. The device is a module that is mounted between the body and the head of the switch that can be rotated independently from the head. The reset device has the following advantages:

- can be integrated into the majority of standard actuator heads;
- contact blocks with snap action are no more necessary because the tripping movement is executed by the reset device itself;
- can be rotated independently from the head ensuring maximum flexibility during installation;
- can be delivered with two different actuating forces: standard and increased for vibration applications;
- mechanical endurance: 1 million operating cycles.

Contact type
R = snap action
L = slow action

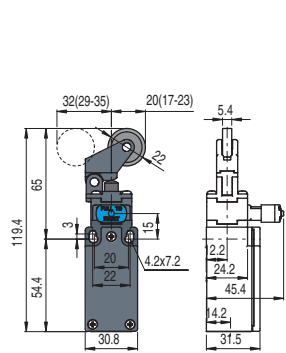
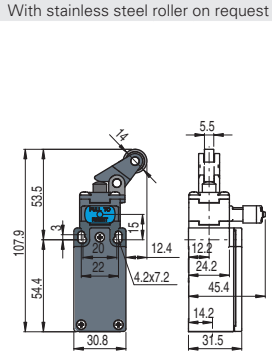
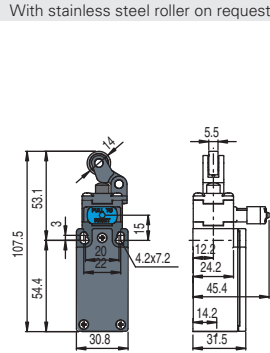
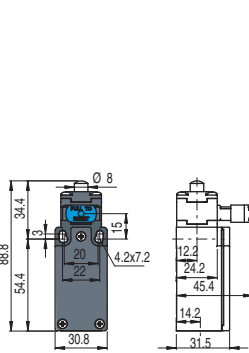

Contact block

2	R	FM 201-W3M2	2x(1NO-1NC)	FM 202-W3M2	2x(1NO-1NC)	FM 205-W3M2	2x(1NO-1NC)	FM 207-W3M2	2x(1NO-1NC)
6	L	FM 601-W3M2	1NO+1NC	FM 602-W3M2	1NO+1NC	FM 605-W3M2	1NO+1NC	FM 607-W3M2	1NO+1NC
9	L	FM 901-W3M2	2NC	FM 902-W3M2	2NC	FM 905-W3M2	2NC	FM 907-W3M2	2NC
10	L	FM 1001-W3M2	2NO	FM 1002-W3M2	2NO	FM 1005-W3M2	2NO	FM 1007-W3M2	2NO
20	L	FM 2001-W3M2	1NO+2NC	FM 2002-W3M2	1NO+2NC	FM 2005-W3M2	1NO+2NC	FM 2007-W3M2	1NO+2NC
21	L	FM 2101-W3M2	3NC	FM 2102-W3M2	3NC	FM 2105-W3M2	3NC	FM 2107-W3M2	3NC
22	L	FM 2201-W3M2	2NO+1NC	FM 2202-W3M2	2NO+1NC	FM 2205-W3M2	2NO+1NC	FM 2207-W3M2	2NO+1NC
Max. speed		page 229 - type 4		page 229 - type 3		page 229 - type 3		page 229 - type 3	
Actuating force		4.5 N (25 N ⊕)		4 N (25 N ⊕)		4 N (25 N ⊕)		2.5 N (25 N ⊕)	
Travel diagrams		page 231 - group 1		page 231 - group 2		page 231 - group 2		page 231 - group 3	

Contact type
R = snap action
L = slow action

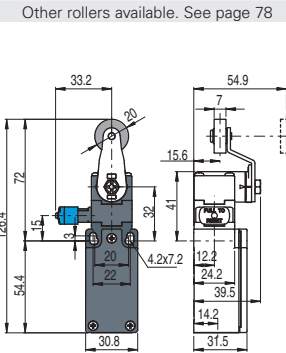
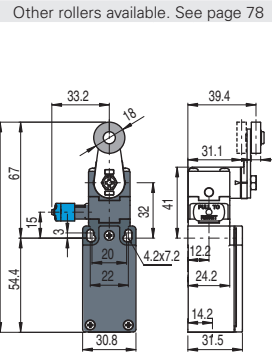
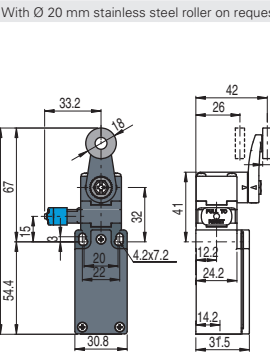
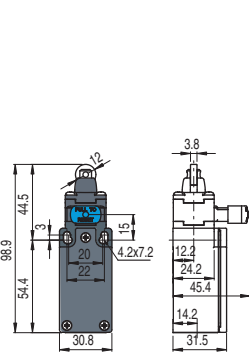

Contact block

2	R	FM 215-W3M2R28	2x(1NO-1NC)	FM 230-W3M2	2x(1NO-1NC)	FM 231-W3M2	2x(1NO-1NC)	FM 251-W3M2	2x(1NO-1NC)
6	L	FM 615-W3M2R28	1NO+1NC	FM 630-W3M2	1NO+1NC	FM 631-W3M2	1NO+1NC	FM 651-W3M2	1NO+1NC
9	L	FM 915-W3M2R28	2NC	FM 930-W3M2	2NC	FM 931-W3M2	2NC	FM 951-W3M2	2NC
10	L	FM 1015-W3M2R28	2NO	FM 1030-W3M2	2NO	FM 1031-W3M2	2NO	FM 1051-W3M2	2NO
20	L	FM 2015-W3M2R28	1NO+2NC	FM 2030-W3M2	1NO+2NC	FM 2031-W3M2	1NO+2NC	FM 2051-W3M2	1NO+2NC
21	L	FM 2115-W3M2R28	3NC	FM 2130-W3M2	3NC	FM 2131-W3M2	3NC	FM 2151-W3M2	3NC
22	L	FM 2215-W3M2R28	2NO+1NC	FM 2230-W3M2	2NO+1NC	FM 2231-W3M2	2NO+1NC	FM 2251-W3M2	2NO+1NC
Max. speed		page 229 - type 2		page 229 - type 1		page 229 - type 1		page 229 - type 1	
Actuating force		4.5 N (25 N ⊕)		0.07 Nm (0.25 Nm ⊕)		0.07 Nm (0.25 Nm ⊕)		0.07 Nm (0.25 Nm ⊕)	
Travel diagrams		page 231 - group 1		page 231 - group 4		page 231 - group 4		page 231 - group 4	

		Other rollers available. See page 78		Other rollers available. See page 78		Other rollers available. See page 78		Other rollers available. See page 78	
Contact type		R = snap action L = slow action							
Contact block									
2	R	FM 252-W3M2	2x(1NO-1NC)	FM 254-W3M2	2x(1NO-1NC)	FM 256-W3M2	2x(1NO-1NC)	FM 257-W3M2	2x(1NO-1NC)
6	L	FM 652-W3M2	1NO+1NC	FM 654-W3M2	1NO+1NC	FM 656-W3M2	1NO+1NC	FM 657-W3M2	1NO+1NC
9	L	FM 952-W3M2	2NC	FM 954-W3M2	2NC	FM 956-W3M2	2NC	FM 957-W3M2	2NC
10	L	FM 1052-W3M2	2NO	FM 1054-W3M2	2NO	FM 1056-W3M2	2NO	FM 1057-W3M2	2NO
20	L	FM 2052-W3M2	1NO+2NC	FM 2054-W3M2	1NO+2NC	FM 2056-W3M2	1NO+2NC	FM 2057-W3M2	1NO+2NC
21	L	FM 2152-W3M2	3NC	FM 2154-W3M2	3NC	FM 2156-W3M2	3NC	FM 2157-W3M2	3NC
22	L	FM 2252-W3M2	2NO+1NC	FM 2254-W3M2	2NO+1NC	FM 2256-W3M2	2NO+1NC	FM 2257-W3M2	2NO+1NC
Max. speed		page 229 - type 1		page 229 - type 1		page 229 - type 1		page 229 - type 1	
Actuating force		0.07 Nm (0.25 Nm \rightarrow)		0.07 Nm (0.25 Nm \rightarrow)		0.07 Nm (0.25 Nm \rightarrow)		0.07 Nm (0.25 Nm \rightarrow)	
Travel diagrams		page 231 - group 4		page 231 - group 4		page 231 - group 4		page 231 - group 4	

Increased actuating force

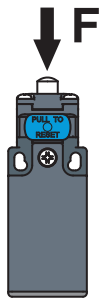

The switch can be delivered with increased actuating force (option W4). Ideal for vibration applications.

Actuators	Actuating force
01, 14, 15, 16	7 N
02, 05	6 N
07	3.5 N
30 ... 57	0.08 Nm

To order the switch with reset and increased actuating force, replace the -W3 option with -W4 in the order code.

Example: FM 601-W3M2 \rightarrow FM 601-W4M2

Position switches with swivelling lever without actuator

- Contact type
- R** = snap action
 - L** = slow action
 - LO** = slow action, make before break
 - LS** = slow action, shifted
 - LV** = slow action, shifted and spaced
 - LI** = slow action, independent
 - LA** = slow action, close
 - ⏏** = electronic, PNP

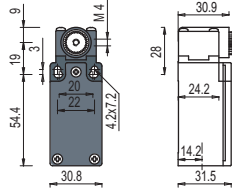

With manual reset knob

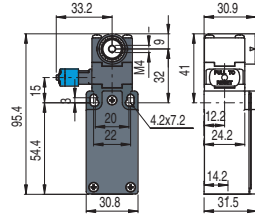

IMPORTANT

For safety applications: join only switches and actuators marked with symbol ⊕ next to the product code. For more information about safety applications see details on page 225.

Contact block

2	R	FM 238-M2	2x(1NO-1NC)	FM 238-W3M2	2x(1NO-1NC)
5	R	FM 538-M2	⊕ 1NO+1NC	/	/
6	L	FM 638-M2	⊕ 1NO+1NC	FM 638-W3M2	⊕ 1NO+1NC
7	LO	FM 738-M2	⊕ 1NO+1NC	/	/
9	L	FM 938-M2	⊕ 2NC	FM 938-W3M2	⊕ 2NC
10	L	FM 1038-M2	2NO	FM 1038-W3M2	2NO
11	R	FM 1138-M2	⊕ 2NC	/	/
12	R	FM 1238-M2	2NO	/	/
13	LV	FM 1338-M2	⊕ 2NC	/	/
14	LS	FM 1438-M2	⊕ 2NC	/	/
15	LS	FM 1538-M2	2NO	/	/
16	LI	FM 1638-M2	⊕ 2NC	/	/
18	LA	FM 1838-M2	⊕ 1NO+1NC	/	/
20	L	FM 2038-M2	⊕ 1NO+2NC	FM 2038-W3M2	⊕ 1NO+2NC
21	L	FM 2138-M2	⊕ 3NC	FM 2138-W3M2	⊕ 3NC
22	L	FM 2238-M2	⊕ 2NO+1NC	FM 2238-W3M2	⊕ 2NO+1NC
E1	⏏	FM E138-M2	1NO-1NC	/	/
Actuating force		0.06 Nm (0.25 Nm ⊕)		0.07 Nm (0.25 Nm ⊕)	
Travel diagrams		page 230 - group 5		page 231 - group 4	

Separate actuators

IMPORTANT: These separate actuators can be used only with items of the FR, FM, FX, FZ and FK series.

Technopolymer roller Ø 18 mm	Technopolymer roller Ø 18 mm	Adjustable square rod, 3x3x125 mm	Spring rod with plastic tip	Adjustable round rod Ø 3x125 mm	Technopolymer roller Ø 20 mm	
VF LE30 ⊕	VF LE31 ⊕	VF LE33	VF LE34	VF LE50	VF LE51 ⊕	
Technopolymer roller Ø 20 mm	Porcelain roller	Technopolymer roller Ø 20 mm	Adjustable actuator with technopolymer roller	Adjustable safety actuator with technopolymer roller	Technopolymer roller Ø 20 mm	Adjustable glass fibre rod
VF LE52 ⊕	VF LE53 ⊕ (2)	VF LE54 ⊕	VF LE55 ⊕ (1)	VF LE56 ⊕	VF LE57 ⊕	VF LE69

All values in the drawings are in mm

Accessories See page 207

→ The 2D and 3D files are available at www.pizzato.com



Special separate actuators

IMPORTANT: These separate actuators can be used only with items of the FR, FM, FX, FZ and FK series.

Stainless steel rollers, Ø 20 mm

VF LE31-R24 (2)	VF LE51-R24 (2)	VF LE52-R24 (2)	VF LE54-R24 (2)	VF LE55-R24 (2) (1)	VF LE56-R24 (2)	VF LE57-R24 (2)

Technopolymer rollers, Ø 35 mm

VF LE31-R25 (4)	VF LE51-R25 (4)	VF LE52-R25 (2)	VF LE54-R25 (4)	VF LE55-R25 (2) (1)	VF LE56-R25 (2)	VF LE57-R25 (2)

Rubber rollers, Ø 40 mm

VF LE31-R5 (4)	VF LE51-R5 (4)	VF LE52-R5 (2)	VF LE54-R5 (4)	VF LE55-R5 (2) (1)	VF LE56-R5 (2)	VF LE57-R5 (4)

Rubber rollers, Ø 50 mm

VF LE51-R26 (4)	VF LE52-R26 (4)	VF LE54-R26 (4)	VF LE55-R26 (2) (1)	VF LE56-R26 (2)	VF LE57-R26 (4)

Protruding rubber rollers, Ø 50 mm

VF LE55-R27 (1)	VF LE56-R27 (2)

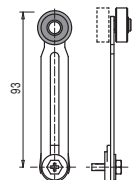

- (1) Lever VF LE55 can only be used in safety applications if adjusted to its max. length, as shown in the figure to the right. If an adjustable lever is required for safety applications, use the VF LE56 adjustable safety lever.
- (2) The position switch obtained by assembling switch FM •38-M2 (e.g. FM 538-M2, FM 638-M2, ...) with actuator VF L53 will not present the same travel diagrams and actuating forces as switch FM •53-E0M2V9 (e.g. FM 553-E0M2V9, FM 653-E0M2V9, ...).
- (4) The actuator cannot be rotated to the inside because it will hit the switch head upon actuation.

All values in the drawings are in mm

Accessories See page 207

→ The 2D and 3D files are available at www.pizzato.com